

Repair Manual



K75 – K100 LT
All 2V Models



**BMW Motorrad GmbH + Co.
Service Department**

dated: 4.1988

scann: 12.2011

Order No: 01 51 9 798 791

by a kind approval of the BMW AG for
www.flyingbrick.de

This manual is based on the org BMW Repair manual

This file is an almost global cooperation to assure that all information for our old bikes will be available after the org book is sold out.

Involved:

Australia, UK ,Ireland , Canada, Germany

Printing:

**Take a modern laser printer (duplex) and print each chapter seperatly.
Org.size is A5, printing in A4 is possible**

The file only shows the K-Models up to 1988.

Not shown is: ABS 1 – for that you've to take the K1100 file

I've only added infos in chapter 31 for K75 Showa frontfork from 8.1991 up

Thx and regards to all who made it possible

6.12.2011

Table of contents

Section	Chapter	Page
00	Maintenance and general instructions	00–01.0
	Introduction	00–03.0
11	Engine	11–01.1
12	Engine-electrical system	12–01.0
13	Fuel supply and mixture control	13–01.0
16	Fuel tank and lines	16–01.0
17	Radiator	17–01.0
18	Exhaust system	18–01.0
21	Clutch	21–01.0
23	Gearbox	23–01.0
31	Front fork	31–01.0
32	Steering	32–01.0
33	Rear wheel drive	33–01.0
34	Brakes	34–01.0
36	Wheels and tyres	36–01.0
46	Frame, fairing	46–01.0
51	Equipment	51–01.0
52	Dualseat	52–01.0
61	General electrical system	61–01.0
62	Instruments	62–01.0
63	Lights	63–01.0

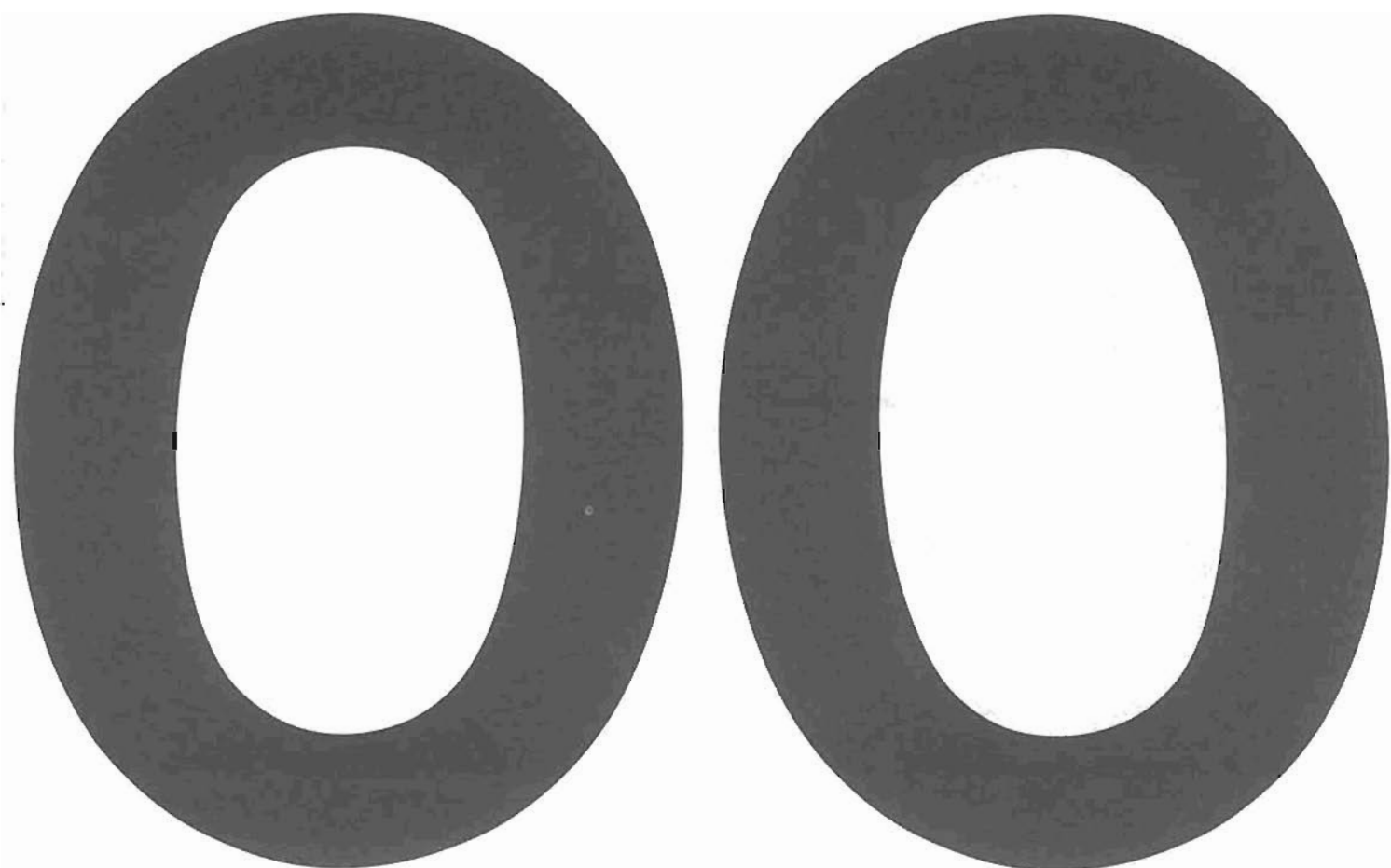



Maintenance and general instructions

00 Maintenance and general instructions

Introduction	00-03.0
Tightening torques to BMW standards	00-05.0
Conversion and comparisons table	00-07.0
From delivery of the motorcycle until sale	
Removing motorcycle from crate	00-11.0
Checking motorcycle for missing items	00-14.0
Completing the motorcycle	00-15.0
Pre-delivery check	
Battery – removing and installing	00-21.0
Battery – filling with acid	00-22.0
Battery – charging	00-22.0
Brake fluid	00-22.0
Tightening torques and tyre pressures – checking	00-23.0
Lights and indicators – checking	00-23.0
Final functional check	00-23.0
Final remarks	00-23.0
BMW maintenance and inspection chart	
Driveline	00-25.0
Frame	00-27.0
Servicing materials, K models	00-28.0
Service data	00-29.0
Engine oil viscosity chart	00-30.0
Determining engine oil consumption	00-30.0
Driveline maintenance and servicing	
Engine oil – changing	00-31.0
Gear oil – changing	00-31.0
Final drive oil – changing	00-32.0
Rear wheel inductive transmitter – cleaning	00-32.0
Spark plug electrode gap – checking	00-32.0
Determining state of engine from spark plug appearance	00-33.0
Spark plugs – renewing	00-34.0
Clutch cable nipple – greasing	00-34.0
Clutch play – checking, adjusting	00-34.0
Valve play – checking, adjusting	00-35.0
Air cleaner element – removing and installing	00-36.0
Cable play (throttle, increased starting speed) – checking	00-40.0
Frame maintenance and servicing	
Oil in telescopic fork – changing	00-42.0
Steering bearing play – checking, adjusting	00-43.0
Fuel filter – renewing	00-45.0
Brakes – checking	00-46.0
Brake fluid – changing	00-46.0
Brake pads and discs – checking for wear	00-48.0
Battery acid level – checking	00-49.0
Coolant concentration – checking	00-49.0
Free travel at footbrake – checking, adjusting	00-51.0
Screws and nuts – taking up slack	00-51.0
Final check	00-52.0

Introduction

This Workshop Manual covers K series 3- and 4-cylinder models. Where there are differences between 3- and 4-cylinder models, the symbol  refers to the 3-cylinder version and  to the 4-cylinder version. If a deviation applies to only one or two models, the relevant models designation is stated directly.

This Workshop Manual is intended to help you carry out all the major repair and maintenance operations on the motorcycle correctly. It should be referred to whenever necessary by workshop personnel, as an extension of the theoretical and practical knowledge acquired at our Service Training School. Reference to this information is essential as a means of increasing the quality of servicing work still further.

When the contents of the Workshop Manual have to be added to or amended, this issue will be replaced. The relevant sections of the contents are marked with the new issue date. Old Workshop Manual microfiches should be destroyed.

All illustrations and texts refer to motorcycles to standard specification or equipped only with Genuine BMW Accessories, and not to motorcycles which have been otherwise modified in any way.

Instructions for use:

- The order of appearance in this Manual is according to main group numbers 00 ... 71, as also used in the Flat Rate Manual.
- Group 00 includes all maintenance, inspection and adjustment procedures, together with the technical data required for these tasks.
- The tasks involved in a motorcycle inspection are listed in a maintenance and inspection chart. The extent of inspection and maintenance work is coded I, II or III. These codes are also given with the subsequent description of each procedure in order to permit uninterrupted work.
- Example of page numbering:

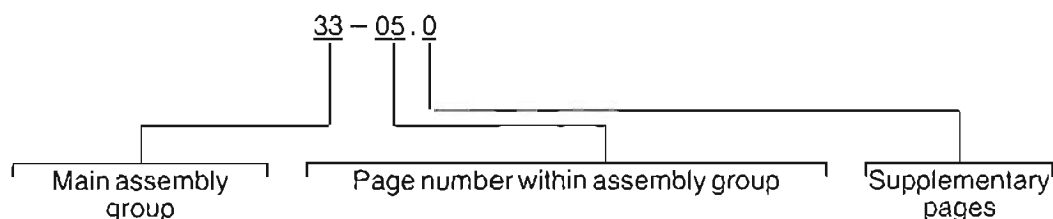

- Use of BMW Special Tools is explained in the individual work descriptions.
- Detaching/removing or dismantling/stripping work is normally described. If the procedures for removal and reinstalling are identical except in the reverse order, only the procedure for removal is described and an appropriate note is provided.

Repair instructions are also issued as Service Information when necessary. The details are incorporated into the next issue of the Workshop Manual. As an aid to repair and servicing work, you are also recommended to consult the illustrations in the Parts microfiche.

BMW Motorrad GmbH + Co.
Technical Service Department

Published by: BMW Motorrad GmbH + Co.
Triebstraße 32
8000 Munich 50
Federal Republic of Germany

All rights reserved. Not to be reprinted, translated or reproduced wholly or in part without written permission.
Subject to technical amendments; errors and omissions excepted.
Printed in West Germany

Tightening torques

BMW N 600 02.0

Valid only for bolts and screws to German DIN 912, 931, 933, 960, 961 and 6912 standard and nuts with a height of $0.8 \times d$ to DIN 934 standard, solely for total $\mu = 0.14$

(Bolt or screw phosphatised, nut galvanized or untreated. Either oiled or dry.)

For **cadmium-plated** bolts or nuts (total $\mu \approx 0.08$ to 0.09) the **tightening torque** for the same strength limit utilisation of the bolt material must be **30% lower** than stated in the table.

Not valid if the thread has any other surface treatment or lubrication, or for different nut heights. In such cases the values must be specially calculated.

Not valid for screws or bolts of the expansion type, for self-locking threaded connections or when components made from different materials are used to form the threaded joint.

The strength utilisation factor for bolts with standard metric thread is:

$$\sigma_{red} = 0,09 \cdot \sigma_{0,2}$$

Thread	Tightening torque, max. (Nm) $M_{sp} = M_A \text{ max.}$						Tightening torque M_A (Nm) Threaded connection class III $M_A = 0,89 \times M_{sp} \pm 12\%$					
	Strength classification acc. to DIN 267						Strength classification acc. to DIN 267					
	5.6	6.8	6.9	8.8	10.9	12.9	5.6	6.8	6.9	8.8	10.9	12.9
M6	4.7	7.5	8.4	9.9	14.0	16.5	4.2 \pm 0.5	6,7 \pm 0,8	7.5 \pm 0.9	8.8 \pm 1.1	12.5 \pm 1.5	14.7 \pm 1.8
M8	11.0	18.0	20.0	24.0	34.0	40.0	9.8 \pm 1.2	16.0 \pm 1.9	17.8 \pm 2.1	21.4 \pm 2.6	30.3 \pm 3.6	35.6 \pm 4.3
M10	23.0	36.0	40.0	47.0	66.0	79.0	20.5 \pm 2.5	32.0 \pm 3.8	35.6 \pm 4.3	41.8 \pm 5.0	58.7 \pm 7.1	70.3 \pm 8.4
M8x1	12.0	19.5	22.0	25.0	36.0	44.0	10.7 \pm 1.3	17.4 \pm 2.1	19.6 \pm 2.4	23.1 \pm 2.8	32.0 \pm 3.8	39.2 \pm 4.7
M10x1	25.0	40.0	45.0	54.0	75.0	91.0	22.3 \pm 2.7	35.6 \pm 4.3	40.1 \pm 4.8	48.1 \pm 5.8	66.8 \pm 8.0	81.0 \pm 9.7
M12x1.5	41.0	55.5	73.5	87.0	123.0	147.0	36.5 \pm 4.4	49.4 \pm 5.9	65.4 \pm 7.8	77.4 \pm 9.3	109.5 \pm 13.1	130.8 \pm 15.7
M14x1.5	67.0	107.0	120.0	143.0	200.0	240.0	50.7 \pm 6.1	95.2 \pm 11.4	106.7 \pm 12.8	127.3 \pm 15.3	178.0 \pm 21.4	213.6 \pm 25.6
M16x1.5	101.0	162.0	182.0	216.0	303.0	364.0	89.9 \pm 10.8	144.2 \pm 17.3	162.0 \pm 19.4	192.2 \pm 23.1	269.7 \pm 32.4	324.0 \pm 38.9
M18x1.5	147.0	234.0	264.0	313.0	440.0	527.0	130.8 \pm 15.7	208.3 \pm 25.0	235.0 \pm 28.2	278.6 \pm 33.4	391.6 \pm 47.0	469.0 \pm 56.3
M20x1.5	204.0	326.0	367.0	435.0	612.0	734.0	181.6 \pm 21.8	290.1 \pm 34.8	326.6 \pm 39.2	387.2 \pm 46.5	544.7 \pm 65.4	653.3 \pm 78.4

The values stated in the above tables apply to threaded connections in accordance with the above conditions. The tightening torque including tolerance is only indicated on the general arrangement or assembly drawing if:

- a) a value which differs from the Standard is needed for functional reasons,
- b) the strength classification of the bolt and nut is not evident.

Important note: All deviations from this table are individually stated in the Specifications.

Conversion and comparison table for statutory measurement units

Name of unit		unit symbols		Values		
		old	new			
Length		m	m	1 m = 1000 mm	1 km = 1000 m	1 μm = 0.01 mm
Area		m ² sq.m	m ²	1 m ² = 10 ⁶ mm ²	1 mm ² = 0.01 cm ²	
Volume		m ³ cu.m	m ³	1 m ³ = 10 ⁶ cm ³	1 dm ³ = 0.001 m ³	
		l	l	1 l = 1 dm ³		
Angle	surface	°	° rad	1 rad = 1 m/m ≈ 57°	1° = π/180 rad	
	spatial	(°) ²	sr	1 sr = 1 m ² /m ²	(1°) ² = (π/180) ² sr	
Mass		kg	kg	1 kg = 1000 g	1 g = 1000 mg	1 t = 1 Mg = 1000 kg
Density		kg/m ³	kg/m ³	1 kg/m ³ = 0.001 kg/dm ³ 1 kg/dm ³ = 1 kg/l		
Imbalance		kgm	kgm	1 kgm = 1000 000 gmm		
Time		sec s	s	1 min = 60 s	1 h = 60 min	
Speed of rotation		rps	1/s	1 rpm = 1/min	1/min = 1/(60 s)	
		rpm	1/min			
Speed (velocity)		m/s	m/s	1 m/s = 3.6 km/h		
Acceleration		m/s ²	m/s ²			
Force		kp	N	1 N = 1 kgm/s ²	1 kp = 9,81 N	
Pressure (gas, liquid)		atm	N/m ² Pa bar	1 atm = 1 kp/cm ² = 0.981 bar = 98 066.5 Pa		
		kp/cm ²		1 m WS = 9806.65 Pa = 9806.65 N/cm ²		
		mWS		1 Torr = 1.333 224 mbar		
		Torr		1 mmHg = 133.322 Pa = 133.322 N/m ²		
Mechanical stress		kp/mm ²	N/m ² Pa N/mm ²	1 N/m ² = 1 Pa 1 kp/mm ² = 9.81 N/mm ²		
Energy, work, quantity of heat		kpm hp/s cal	J kWh	1 J = 1 Nm	1 kWh = 3.6 MJ	1 kpm = 9.81 J
				1 cal = 4.1868 J		
Torque		kpm	Nm	1 kmp = 9,81 Nm		
Power output		hp	kW	1 kW = 1000 W	1 W = 1 Nm/s = 1 J/s	
		kpm/s	Nm/s	1 PS = 736 W = 75 kpm/s = 632 kcal/h		
		kcal/h		1 kW = 1.36 PS = 102 kpm/s = 860 kcal/h = 0.239 kcal/s		
Viscosity	dynamic	P	Pas	1 Pas = 1 Ns/m ²	1 P = 0.1 Pas = 1 g/cms	
	kinematic	St	m ² /s	1 m ² /s = 1 Pas m ³ /kg	1 St = 1 cm ² /s = 0.0001 m ² /s	
Temperature		deg °C °K	°C K	0°C ≙ 273.15 K 1 grd = 1°K = 1 K = 1°C (temperature difference)		
Electric current		A	A	1 mA = 0.001 A	1 kA = 1000 A	
Electric voltage		V	V	1 V = 1 W/A	1 mV = 0.001 V	1 MV = 10 ⁶ V
Electric resistance		Ω	Ω	1 Ω = 1 V/A = 1/S		
Magnetic flux		M	Wb, Vs	1 Wb = 1 Vs	1 M = 10 ⁻⁸ Wb	
Magnetic flux density		G	T	1 T = Wb/m ²	1 G = 10 ⁻⁴ T	
Magnetic field strength		0e	A/m	1 A/m = 1 N/Wb	1 0e = 10 ³ /4π A/m	
Light intensity		HK	cd	1 cd = 1.107 HK	1 HK = 0.903342 cd	
Illumination density		sb	cd/m ²	1 sb = 10 ⁴ cd/m ²		
Illumination intensity		ph	lx	1 ph = 10 ⁴ lx		

Conversion table

From metric system:		To British (Imp.)/US system:		Multiply by conversion factor:
Length				
Millimetres	mm	Inches	in	0.039
Centimetres	cm	Inches	in	0.394
Metres	m	Feet	ft	3.281
Kilometres	km	Miles	mile	0.621
Area				
Square centimetres	cm ²	Square inches	sq.in, in ²	0.155
Volume				
Cubic centimetres	cc, cm ³	Cubic inches	cu.in, in ³	0.061
Litres	l	Fluid ounces (US)	US fl.oz	33.813
		Fluid ounces (Imp.)	Imp. fl.oz	35.195
		Pints (US)	US pt	2.113
		Pints (Imp.)	Imp. pt	1.760
		Quarts (US)	US qt	1.057
		Quarts (Imp.)	Imp. qt	0.880
		Gallons (US)	US gal	0.264
		Gallons (Imp.)	Imp. gal	0.220
Weight				
Kilogrammes	kg	Pounds	lb	2.205
Pressure				
Bar	bar	Pounds force/square inch	psi (lb.f/in ²)	14.504
Power				
Kilowatts	kW	Horsepower	hp	1.341
Torque				
Newton metres	Nm	Foot pounds	ft.lb	0.723
Speed				
Kilometres/hour	km/h	Miles/hour	mile/h (mph)	0.621
Metres/second	m/s	Feet/second	ft/s	3.281
Consumption				
Litres/kilometre	l/100 km	Miles/gallon (US)	mile/gal (US)	$\frac{235.21}{\text{value in l/100 km}}$
		Miles/gallon (Imp.)	mile/gal (Imp.)	$\frac{282.48}{\text{value in l/100 km}}$
		Miles/pint (US)	mile/pt (US)	$\frac{29.40}{\text{value in l/100 km}}$
		Miles/pint (Imp.)	mile/pt (Imp.)	$\frac{35.30}{\text{value in l/100 km}}$
Weight per unit power				
Kilogrammes/kilowatt	kg/kW	Brake horsepower/ton	bhp/ton (US)	$\frac{1216.55}{\text{value in kg/kW}}$
		Brake horsepower/ton	bhp/ton (Imp.)	$\frac{1362.55}{\text{value in kg/kW}}$

Conversion table

From British (Imp.)/US system:		To metric system:		Multiply by conversion factor:
Length				
Inches	in	Millimetres	mm	25.400
Inches	in	Centimetres	cm	2.540
Feet	ft	Metres	m	0.305
Miles	mile	Kilometres	km	1.609
Area				
Square inches	sq.in, in ²	Square centimetres	cm ²	6.452
Volume				
Cubic inches	cu.in, in ³	Cubic centimetres	cc, cm ³	16.387
Fluid ounces (US)	US fl.oz	Litres	l	0.030
Fluid ounces (Imp.)	Imp. fl.oz	Litres	l	0.028
Pints (US)	US pt	Litres	l	0.473
Pints (Imp.)	Imp. pt	Litres	l	0.568
Quarts (US)	US qt	Litres	l	0.946
Quarts (Imp.)	Imp. qt	Litres	l	1.137
Gallons (US)	US gal	Litres	l	3.785
Gallons (Imp.)	Imp. gal	Litres	l	4.546
Weight				
Pounds	lb	Kilogrammes	kg	0.454
Pressure				
Pounds force/square inch	psi (lb.f/in ²)	Bar	bar	0.069
Power				
Horsepower	hp	Kilowatts	kW	0.746
Torque				
Foot pounds	ft.lb	Newton metres	Nm	1.383
Speed				
Miles/hour	mile/h (mph)	Kilometres/hour	km/h	1.610
Feet/second	ft/s	Metres/second	m/s	0.305
Consumption				
Miles/gallon (US)	mile/gal (US)	Litres/kilometre	l/100 km	$\frac{235.21}{\text{value in mile/gal}}$
Miles/gallon (Imp.)	mile/gal (Imp.)	Litres/kilometre	l/100 km	$\frac{282.48}{\text{value in mile/gal}}$
Miles/pint (US)	mile/pt (US)	Litres/kilometre	l/100 km	$\frac{29.40}{\text{value in mile/pt}}$
Miles/pint (Imp.)	mile/pt (Imp.)	Litres/kilometre	l/100 km	$\frac{35.30}{\text{value in mile/pt}}$
Weight per unit power				
Brake horsepower/ton (US)	bhp/ton (US)	Kilogrammes/kilowatt	kg/kW	$\frac{1216.55}{\text{value in bhp/ton}}$
Brake horsepower/ton (Imp.)	bhp/ton (Imp.)	Kilogrammes/kilowatt	kg/kW	$\frac{1362.55}{\text{value in bhp/ton}}$

Removing motorcycle from crate

Note:

Before removing the motorcycle from its crate, check the crate for damage and its contents for any consequential damage.

If any damage is detected, notify the carrier immediately.

Insert a suitable tool under the lid at the points where it is nailed on and lever up the lid, working from the cross struts to the centre of the crate.



Cut open the sheeting with a knife (vertically at the ends and horizontally at the sides) and remove.



Cut open the sheeting bag and remove the mirror and battery covers, also windshield on K 75 c, K 75 s and K 100 RT.





First remove the cross struts.

Do not knock off the cross struts from underneath with a hammer or similar object, as there is a risk of damaging the vehicle.

- 1 – Push off the side section
- 2 – Twist up the cross strut



Next remove the ends of the crate, together with the integral case and engine spoiler if included.



Next remove the side sections.

Note:

Do not operate the handbrake lever on the K 100 RS and K 100 RT.

The front wheel is not fitted!



Only applicable to motorcycles packed with front wheel fitted:

Release retaining straps on left and right at front, loosen those on either side at the rear and remove the support under oil sump (arrow).

Release the retaining strap on the left at the rear. Lean over the dual seat and undo the right-hand strap.

Push the motorcycle out to the rear.

Front wheel – installing

K 100 RS, K 100 RT:

Only slacken the retaining straps as far as is possible without the motorcycle falling over. Raise the motorcycle with suitable lifting gear (e.g. crane) and unfasten the straps. Release the brake caliper on the fork slider tube on both sides and the brake line holder.

Allow the brake calipers to hang down freely.

Slacken off the retaining screws (arrows) on either side and remove machine screw (1) from quick-release axle. Pull out quick-release axle.

Lower the motorcycle until the front wheel need not be raised for assembly.

From the right-hand side of the motorcycle, push in the quick-release axle through the clamp block and wheel as far as the stop. Do not forget the spacing sleeve (2) on the left-hand side. Insert machine screw (1) with shim (3) and tighten. Only tighten the retaining screws (arrows) on the left-hand side.

Tightening torque:

Machine screw	$33 \pm 4 \text{ Nm}$
Retaining bolt	$14 \pm 2 \text{ Nm}$

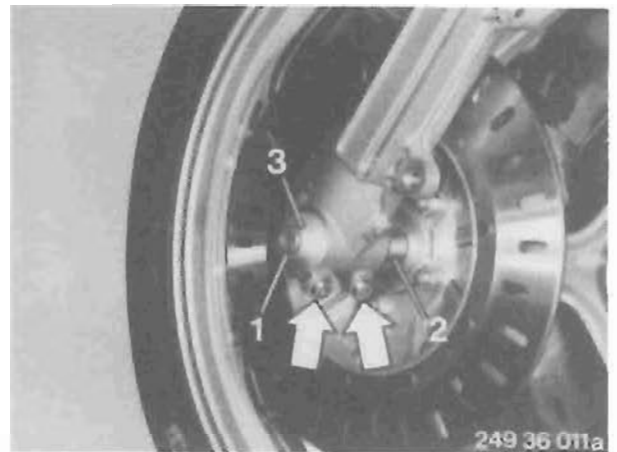

Push the brake caliper onto the brake disc, noting the gap between the brake pads; carefully force apart a slight distance with a suitable wedge if necessary. Affix brake caliper retaining screws (arrow) and washers, and tighten.

Secure the brake line holder to the slider tube.

Tightening torque:

Machine screw	$32 \pm 2 \text{ Nm}$
---------------	-----------------------



Lower the motorcycle and remove from crate base.

Compress the telescopic fork a few times with the handbrake applied. Tighten the retaining screws for the quick-release axle on the right-hand side.

The compressing action is intended to eliminate stresses in the fork.

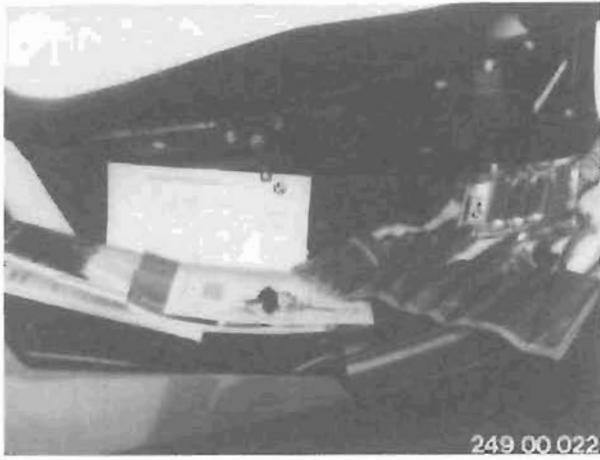

Checking motorcycle for missing items

- Motorcycle toolkit
- Breakdown repair kit
- Rider's Handbook
- List of dealers
- First aid Instructions
- 3 wrenches
(1 folding, 2 rigid)
- Special equipment options

Completing the motorcycle

Fit the mirror.

Note:

Install the corrugated washers above and below the fitting (arrows).

Fit the weights on the steering head tube on either side.



K 100 RS, K 100 RT:

Connect up the electric cables for integral indicator (RS only).

Press mirror on to the journals on the fairing, tilting the mirror in such a way that the pressure is concentrated on one journal only. Press in the lower front journal first, then the lower rear one and finally the top journal.

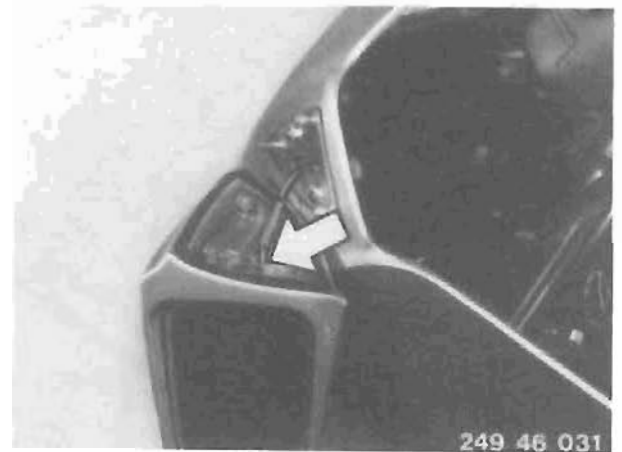

Battery trims – Installing



- Introduce battery trim into rear section with pin (arrow).
- Fix both hooks to weatherstrip on fuel tank (14).
- Allow spring hoop (13) to engage in rubber block on frame.

Note:

- Raise the spring hoop slightly for ease of assembly.

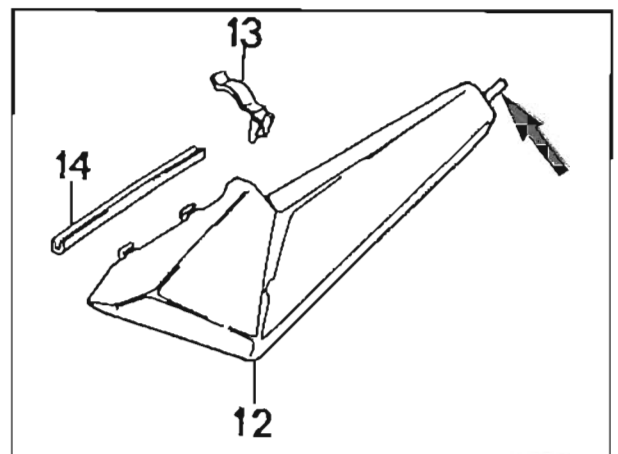

- Introduce battery trim in rear section with pin (arrow).
- Attach with hooks to rubber block (6) on frame from below.
- Press into rubber block (4) at front.

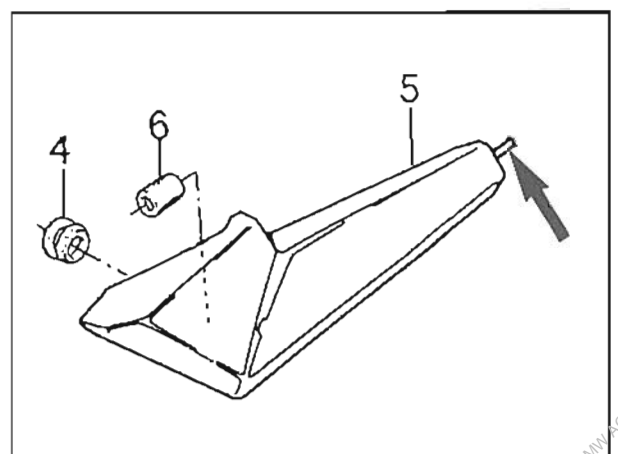

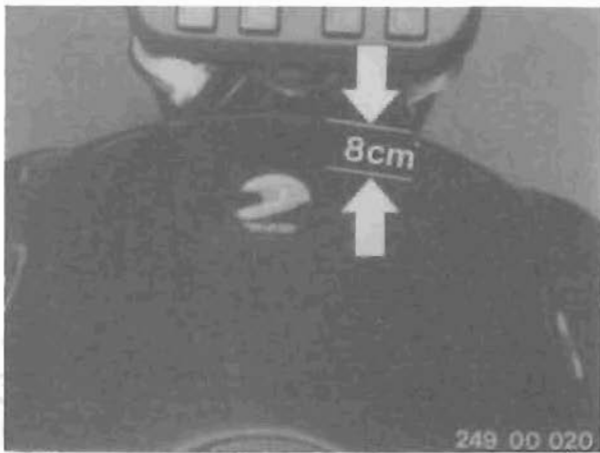

Affix helmet sticker in an appropriate position (app. 8 cm from front edge of fuel tank).
The surface must be absolutely free of grease.

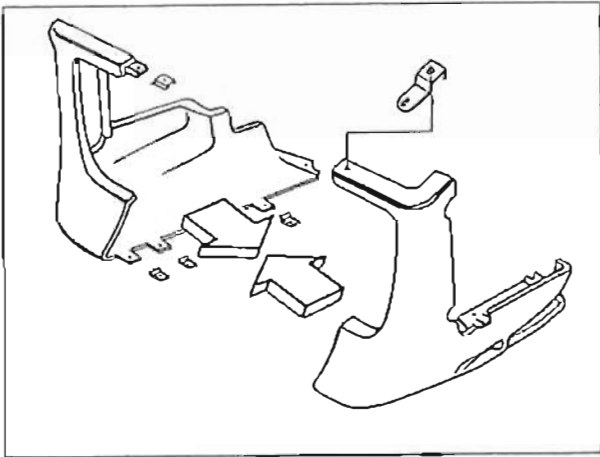

Engine spoiler – assembling and mounting (K 75 s)

Insert five M5 sheet metal nuts at top and base.

Assemble the left-hand and right-hand halves of the spoiler with M5 × 15 cheese-head screws and plastic washers.

Mount the top mounting bracket.

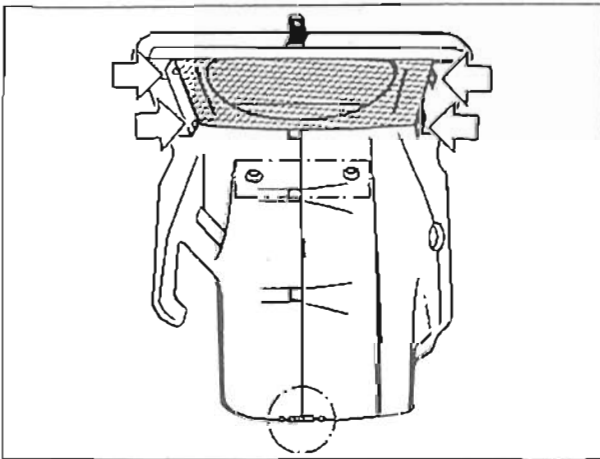

Affix the sealing strips for ventilation grille (see picture); attach the ventilation grille with four 3.5 × 13 cheese-head screws (arrows) and spring washers.

Fit sheet metal nuts (1) on bracket and secure the bracket at rear with 5 × 15 cheese-head screws (3). Fit grommet (4).

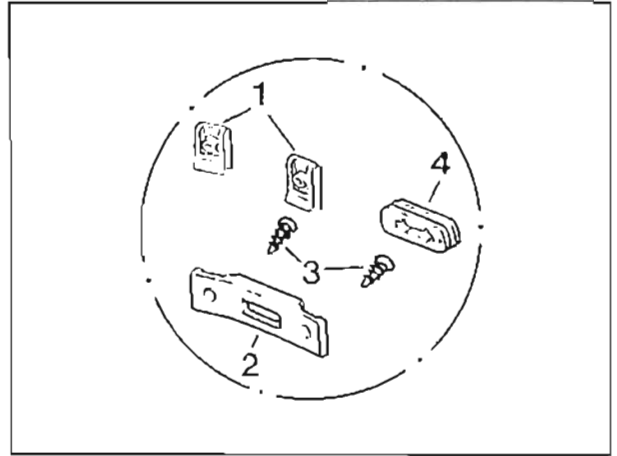

Affix 2 grommets (1) and plastic bushings (2) at front.

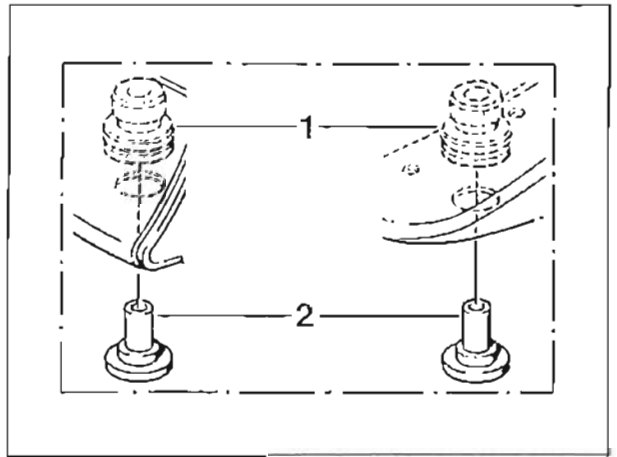

Fitting front holder:

Lever out stoppers at front left of oil sump and front right of crankcase base using a screwdriver. Fit the two M5 sheet metal nuts (1) on holder (2).

Screw on the holder with machine screws and spring washers.

M 10 × 20 on crankcase base

M 8 × 20 on oil sump

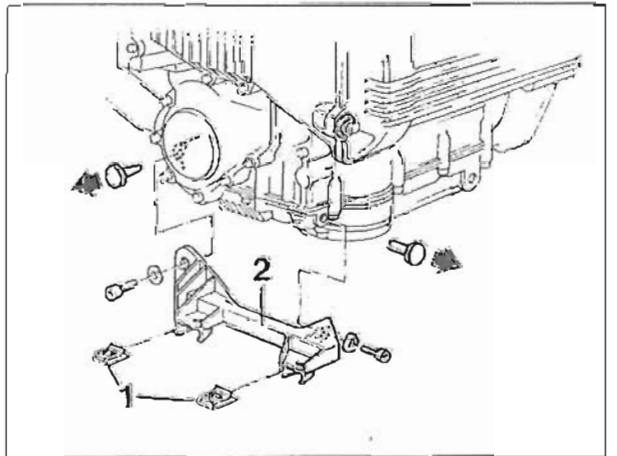

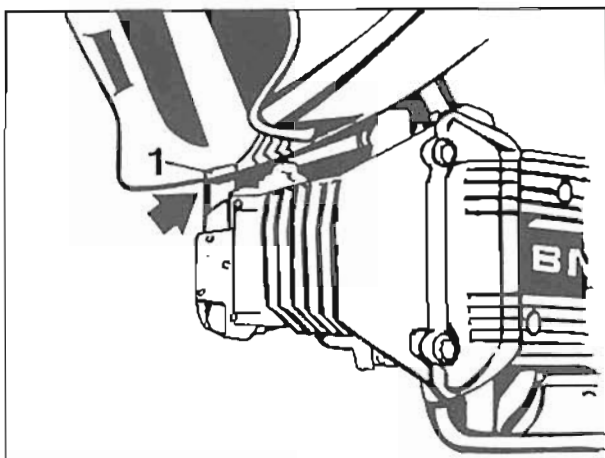

Insert sheet metal nut (1) in upper fairing section (arrow).

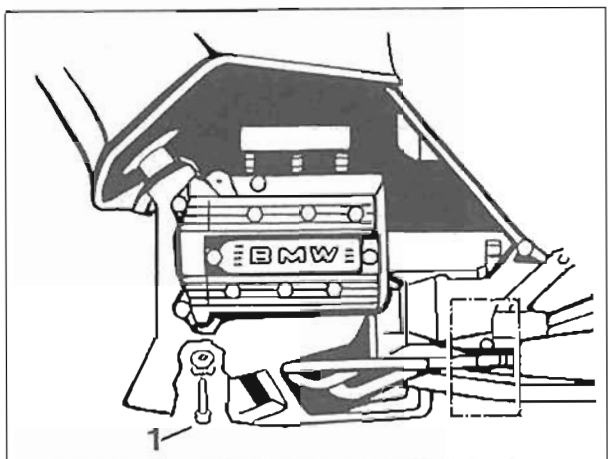

Push engine spoiler and grommet into front holder and secure lightly with M6 x 30 machine screw (1), spring washer and shim.

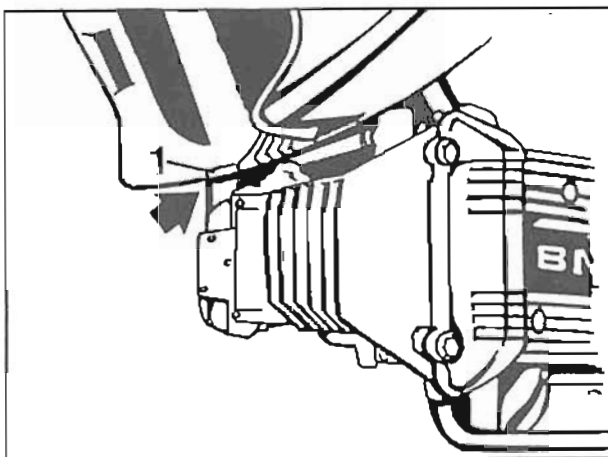

Shim gap between trim and bracket with 20 mm \varnothing plastic washer, 3 and 4 mm thick.
Secure with M6 machine screw and spring washer.

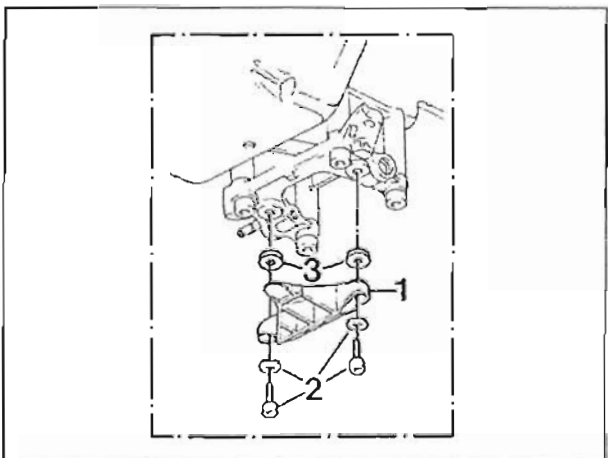

Push tongue of rear bracket into engine spoiler grommet.
Screw on bracket (1) with M10 x 20 machine screws and spring washers (2).
Even out the gap width with the aid of shims (3).

Glue 20 mm foam rubber strips at rear between the spoiler and cylinder head (see picture) to prevent any rattling or vibration.

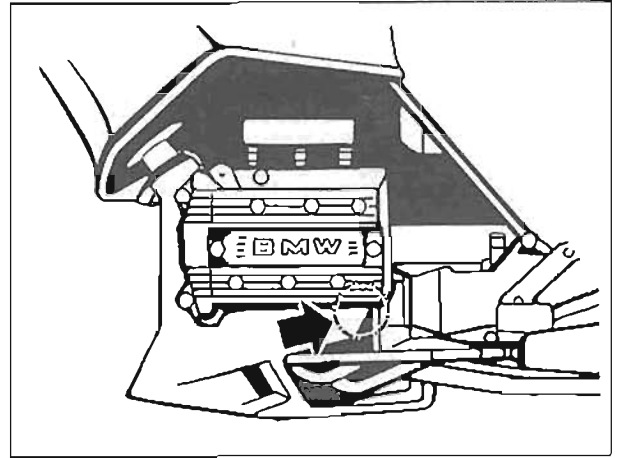

Windshield – fitting

K 75 c:
Locate windscreen with spreader rivets.
Press in pins with riveter BMW 009 510; grease the pins slightly.

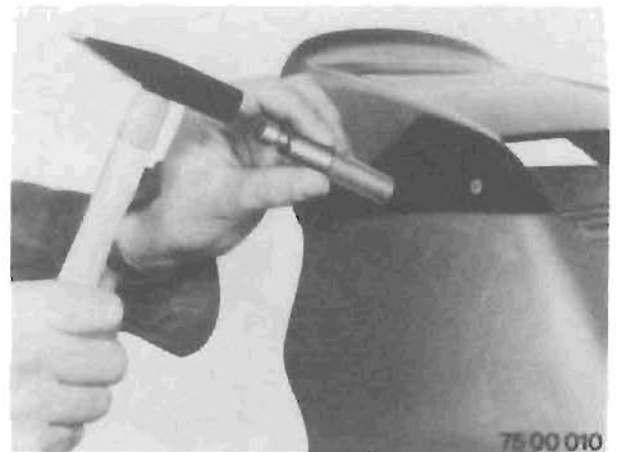

K 75 s:
Screw on the windshield with retaining screws (1) and rubber washers.

Note:
Do not tighten the screws excessively, or the windshield may crack.



K 100 RT:
Push reinforcing piece (1) into fairing.

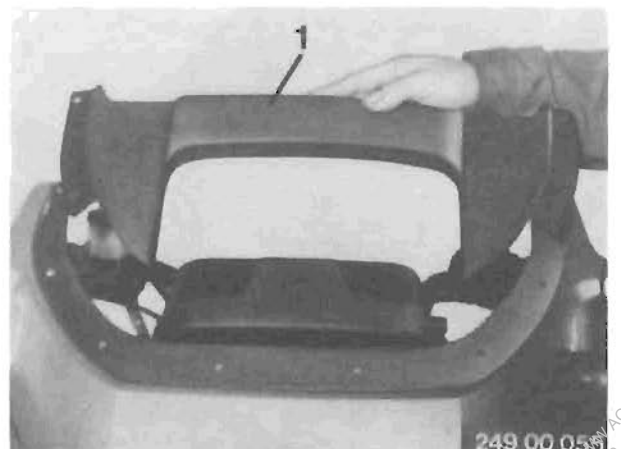

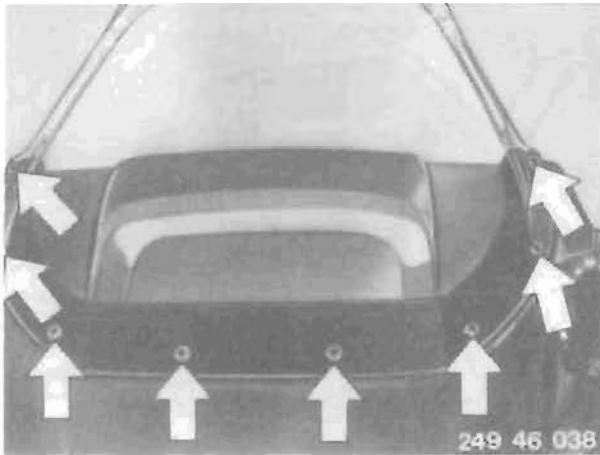

Position windshield on fairing and screw in M 5 × 25 retaining screws (arrows) with hollow discs. Tighten retaining screws, working from the centre outwards.

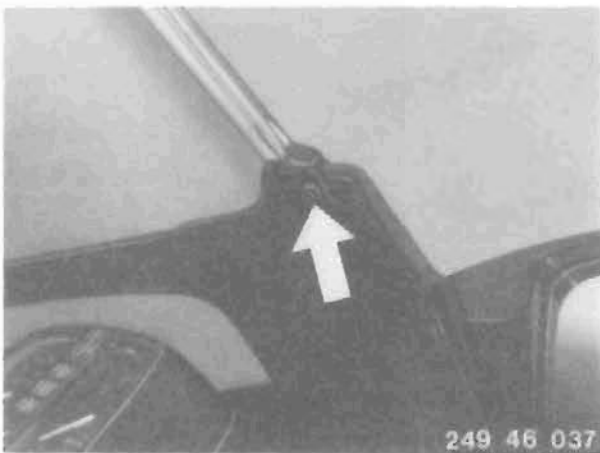

Screw in retaining screw (arrow) on either side with nut and rubber washer from the outside and tighten.

Cleaning the motorcycle

As a rule, all areas treated with a protective coating, in other words chromium plated and bright metal parts, aluminium and brake elements, can easily be cleaned with a clean, soft cloth.

Dry protective coating is removed as follows:

Removing wax with a steam jet:

- Set the temperature to max. 80°C
- Dissolve cleaning agent (protective coating remover) in water (app. 5-7% solution). (See current Service Information for recommended protective coating removers.)
- Hold steam jet at least 30 cm from surfaces.

Removing wax manually:

- Dissolve cleaning agent (protective coating remover) in water (app. 5-7% solution). (See current Service Information for recommended protective coating removers.)
- Apply diluted cleaning agent (protective coating remover) or conventional car shampoo with a spray pistol or cloth.
- Allow to act for app. 10-15 mins.
- Wash off cleaning agent with water no hotter than 80°C.



Degrease brake disc with care!
e.g. with thinners or commercial brake cleaner.

Pre-delivery check

Battery – removing and Installing

Remove left battery cover.

Pull off cover for fuel injection control unit to one side (arrow).

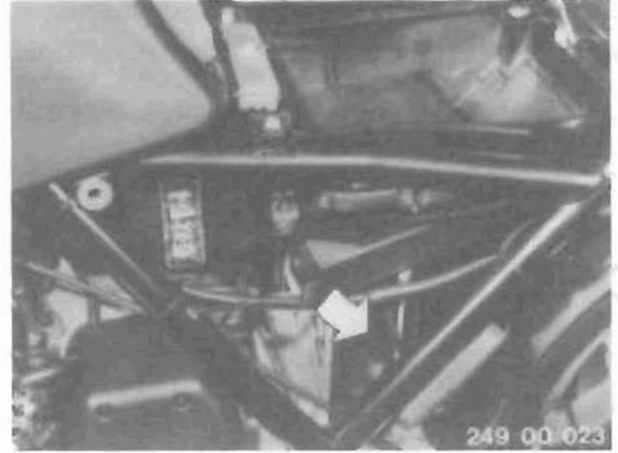

Release catch for fuel injection control unit plug by pushing a screwdriver through the hole in the toolbox.

Pull plug at cable input end out of the control unit.

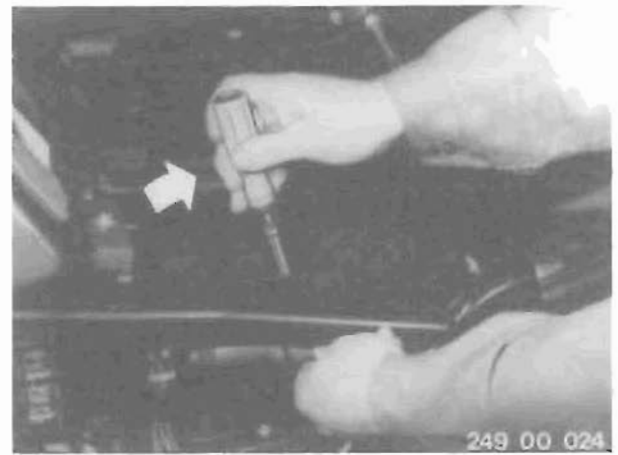

Lift out tool tray and fuel injection control unit.

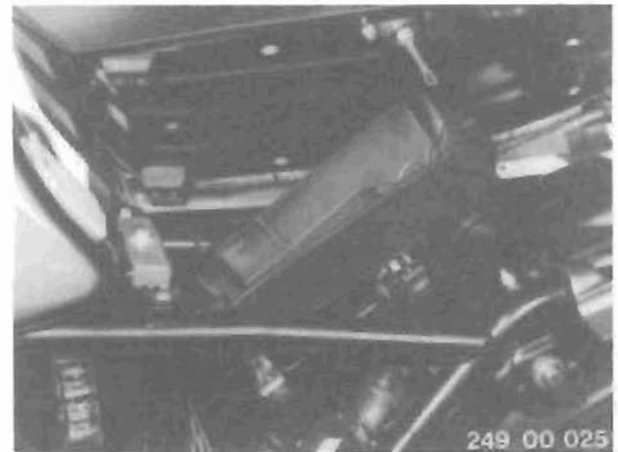

Disconnect battery mounting (arrows) and earth lead.
Remove battery.

Install the battery by following the reverse procedure.

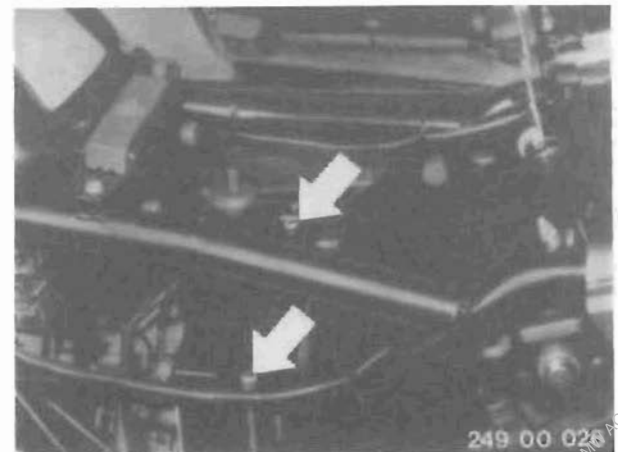

Battery – filling with acid (only immediately before delivery)

- Only fill the battery with acid shortly before it is needed.
- Unscrew the stoppers.
- Fill the battery with pure accumulator sulphuric acid (to VDE 0510, density: 1.28 kg/l, at 20°C acid temperature) up to the specified level (MAX mark).
- Allow the battery to stand for app. 1 hour (the chemical reaction generates heat. Max. temperature 40°C, otherwise there is a risk of short-circuiting between the plates), then shake gently or tilt (to expel air) and top up acid to the correct level if necessary.
- Screw in stoppers loosely (only tighten once the battery has been charged).
- When the dry, pre-charged battery is first filled with acid, it will produce only app. 60% of its rated output. Charging is therefore essential.

Battery – charging

Warning:

Max. charging current must not exceed 10% of the battery capacity.

Example:

25 Amp/h battery = max. 2.5 Amp charging current.

Charging time = 5 ... 10 hours

- Battery charge can be determined by measuring the acid density.
- Acid density when battery fully charged = 1.26 ... 1.30 kg/l at 20°C.
- Shake the battery gently after charging so that any gas bubbles rise to the surface.
- When the fluid has settled again, top up battery acid to MAX. mark if necessary. Screw the stopper in firmly.
- Connect up breather line.

Brake fluid level:

The brake fluid reservoirs at the front ...

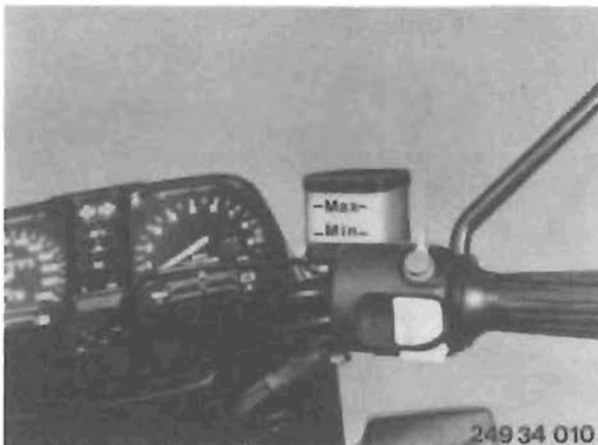

... rear must be filled to between the MIN and MAX marks only (●●●● and K 75 s).

Brake fluid level must never be allowed to fall below the MIN mark, as air may otherwise penetrate into the brake system. Only use quality grade DOT 4 brake fluid if topping up is necessary.

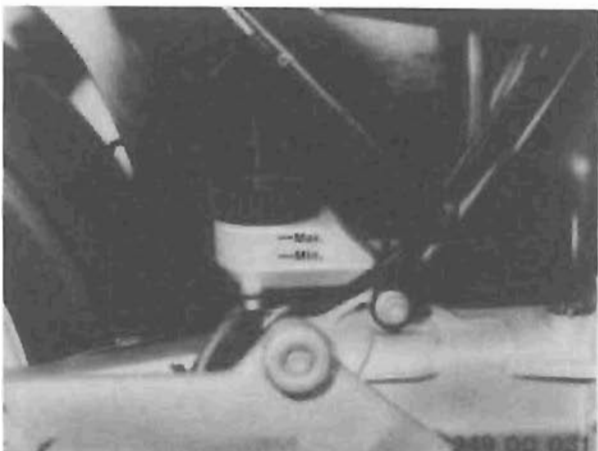

Tightening torque for rear-wheel studs – checking with torque wrench

Rear wheel stud tightening torque: $105 \pm 4 \text{ Nm}$

Tyre pressure (front and rear) – checking

Tyre pressure (bar) – tyres cold

	Speed	V tyres				VR tyres			
		Solo		With pillion		Solo		With pillion	
		Front	Rear	Front	Rear	Front	Rear	Front	Rear
K 75, K 75c		2,0	2,50	2,30	2,90	–	–	–	–
	no limit	2,25	2,50	–	–	–	–	–	–
	up to 180 km/h	–	–	2,25	2,70	–	–	–	–
K 75 s	over 180 km/h	–	–	2,70	2,90	–	–	–	–
K 100, K 100 RS, K 100 RT	no limit	2,25	2,50	–	–	2,55	2,80	–	–
	up to 180 km/h	–	–	2,25	2,70	–	–	2,55	3,00
	over 180 km/h	–	–	2,70	2,90	–	–	3,00	3,20

Lights and indicators – checking

- High-beam and dipped headlight, parking lights;
- Brake and licence plate lights, turn indicators;
- High-beam, battery charge, neutral and oil pressure telltales;
- Horn;

Check functioning of any special equipment features.

Final functional check

Check that clutch, gear shift, steering, footbrake and handbrake are functioning properly, e.g. by test-riding the motorcycle.

Check the engine's idle setting (with warm engine). Idle speed adjustment: see page 13–07.0.

Idle speed: $950 \pm 50 \text{ min}^{-1}$

Check engine, gearbox, final drive, telescopic fork, brake lines and fuel system for leaks.

Confirm the Pre-Delivery Check with stamp and signature in the Rider's Handbook.

Final remarks

Insofar as technically justifiable and when not covered by the working procedure stated, any defects detected should be repaired by the usual warranty arrangements.

In addition, the "BMW motorcycle quality control" sheet should be completed in full and returned.

Maintenance and inspection chart – driveline

	I	II	III		
Driveline	BMW Inspection: 1000 km	BMW Service at 7500 km and every subsequent 15000 km	BMW Inspection at 15000 km and every subsequent 15000 km	Technical Data	Page 00–
Change oil at normal operating temperature Renew oil filter element	X	X ¹⁾	X ¹⁾	3.75 l	031.0
Change gear and final drive oil at normal operating temperature	X	–	X ²⁾	0.85 l 0.26 l	031.0 032.0
Clean inductive transmitter on final drive	X	–	X	2.5 Nm	032.0
Check spark-plug electrode gap	–	X	–	0.6 ... 0.7 mm max. 0.9 mm	032.0
Renew spark plugs			X	20 ± 2 Nm	034.0
Grease clutch cable nipple at top and base	–	X	X		034.0
Check clutch play, adjust if necessary	X	–	X		034.0
Check valve play, adjust if necessary at max. 35°C	X	X	X	10.15-0.2 mm E 0.25-0.3 mm	035.0
Renew intake air cleaner	–	–	X ³⁾		036.0
Check cable play for throttle and increased starting speed (choke), renew if necessary	X	–	X		040.0
Check idle speed, adjust if necessary	X	–	X	950 ± 50 min ⁻¹	041.0
<p>Recommendation: if operated in extreme conditions, regrease the twistgrip and steering bearings every 30 000 km⁴⁾</p> <p>*) Charged for additionally</p> <p>1) At least every 6 months, or every 3 months if used only for short-distance riding or at outside temperatures below 0°C; at least every 3 000 km</p> <p>2) At least once a year</p> <p>3) If severe contamination and dust are encountered, renew every 7 500 km or more often if necessary</p> <p>4) Normally every 30 000 km, or every 15 000 km when fuel quality is poor</p>					

Maintenance and inspection chart – frame

	I	II	III		
Driveline	BMW Inspection: 1000 km	BMW Service at 7500 km and every subsequent 15000 km	BMW Inspection at 15000 km and every subsequent 15000 km	Technical Data	Page 00–
Change oil in telescopic fork	X	–	X	115 ± 2 Nm 09 ± 1 Nm	042.0
Check steering head bearing play, adjust if necessary	–	–	X*)	Conical screw for "Fluidbloc" 9 ± Nm	043.0
Renew fuel filter	–	–	X ⁴⁾		046.0
Check brake pads and discs for wear, renew if necessary. *)	–	–	X		046.0
Change brake fluid	X	–	X	Quality grade DOT 4	046.0
Check battery acid level, top up with distilled water if necessary, clean and grease battery terminals and	–	–	X*)		049.0
Check fuel and cooling system lines for leaks, tighten hose clips. Check coolant concen- tration, adjust if necessary. Change coolant at least every two years.	X*)	–	X*)	60% water 40% antifr. ... –28°C 50% : 50% ... –36°C	049.0
Check footbrake pedal play, adjust if neces- sary. *) (drum brake)	–	–	X	app. 25 mm	051.0
Tighten screws and nuts	X	–	X		051.0
Final check, examine for roadworthiness/functional safety.	X	X	X		052.0

Recommendation: if operated in extreme conditions, regrease the twistgrip and steering bearings every 30 000 km*)

*) Charged for additionally

1) At least every 6 months, or every 3 months if used only for short-distance riding or at outside temperatures below 0°C; at least every 3 000 km

2) At least once a year



3) If severe contamination and dust are encountered, renew every 7 500 km or more often if necessary

4) Normally every 30 000 km, or every 15 000 km when fuel quality is poor

Servicing materials, K models

Application/designation	Sample application	Order No.	Amount
Lubricants			
Staburags NBU 30 PTM High-performance lubricant paste	High-stress splines/ serrations and pressure points on clutch	07 55 9 056 992	75 g tube
		07 55 9 056 993	400 ml spray
		and driveshaft	
Never-Seez Temperature-resistant assembly paste	Bearing inner races on swinging arm	18 21 1 337 498	30 g tube
Uni Moly C 220 Slip agent	Output shaft sections, K 100	11 21 9 056 999	150 ml spray
Silicone grease 300, heavy Damper grease	Fluidbloc, K 75	07 58 9 058 193	10 g tube
RetInax A (Taper roller bearing grease)	Wheel bearings, steering head bearing	HWB 81 22 9 407 302	900 g tin
		HWB 81 22 9 407 303	150 g tube
CRC-Spray Contact spray	Water repellent, anti-friction protection for plugs, protective treatment	HWB 81 22 9 400 208	300 ml spray
Sealants			
3-bond 1207 B Surface sealing	All metal sealing surfaces		30 ml cartridge
Loctite 574 Surface sealing	Metal sealing surfaces on gearbox and final drive	HWB 81 22 9 407 301	50 ml tube
Adhesives and locking agents			
Loctite 242 Screw connections, medium-torque	Damper pistons on piston rod (telescopic fork)	07 58 9 056 031	10 ml bottle
Loctite 270 Screw connections, high-torque	Spring strut eye on piston rod	HWB 81 22 9 400 086	10 ml bottle
Loctite 496 Cyanacrylate	Trims and rubber parts	16 11 1 235 651	10 ml tube
3-Bond 1110 B Joint adhesive	Output shaft bearing K 100 models without shoulder bearing	05 589 056 998	5 g tube

Service data

Item			Reference		Specification
					
Oil capacity	Engine with filter	L	3.75	3.75	Brand HD oil for spark-ignition engines, API classifications SE/CC and SF/CC. SAE class temperature limits can be exceeded or undercut briefly. Brand hypoid gear oil, API-class GL 5 Above 5°C SAE 90 Below 5°C SAE 80 or optionally SAE 80 W 90 Oil grades: see page 31–03.0
	Engine without filter		3.50	3.50	
	Gearbox	L	0.85	0.85	
	Final drive	L	0.26	0.26	
	Telescopic fork, per tube	L	0.33–0.01 K75,C,S 0.28–0.01*)	0.33–0.01 K100 0.36–0.01 K100 RS/RT 0.28–0.01*)	
Coolant		L	2.5 + 0.4 in equalizer tank	2.8 + 0.4 in equalizer tank	60% water to –28°C 40% glycol 50% : 50% to –36°C
Valve clearance	Measured with engine cold, i.e. max. 35°C	mm	E 0.15 ... 0.20 A 0.25 ... 0.30	E 0.15 ... 0.20 A 0.25 ... 0.30	
Ignition timing	Adjustment, static ... equivalent to Control, dynamic	°bTDC mm °bTDC	6 0.24 – Zyl. 3 22	6 0.24 – Zyl. 1 18	
Spark plugs			at app. 3700/min Bosch X 5 DC Beru 12-5 DU	at app. 3200/min Bosch X 5 DC Beru 12-5 DU Champion A 85 YC	
Idle speed	Electrode gap	mm	0.6 + 0.1	0.6 + 0.1	Wear limit 0.9
Bowden cable adjustment for cold starting	Measured at central stop on throttle butterfly strip	min ⁻¹	950 ± 50	950 ± 50	
Clutch play	Stage I	mm	1.5	1.0	
	Stage II	mm	3.0	2.5	
Tyre pressure) Sports settings	Bowden cable at gearbox	mm	75	75	
	Bowden cable at lever	mm	2 + 0.5	4 + 0.5	
See page 00–23.0 or sticker on motorcycle					
Tightening torques			Nm	Nm	
Oil filter			Hand-tight	Hand-tight	
Oil drain plug, engine			18 ± 2	18 ± 2	
Oil filler/drain plug, gearbox			20 ± 3	20 ± 3	
Oil drain plug, final drive			25 ± 3	25 ± 3	
Oil filler plug, final drive			20 ± 2	20 ± 2	
Inductive transmitter, final drive			2.5	2.5	
Rocker cover			6 ± 0.7	6 ± 0.7	
Spark plugs			20 ± 2	20 ± 2	
Circular nut			No play	No play	
Screw lug			75 ± 5		
Plastic nut			10 ± 1		
Locking tube			45 ± 3 (65 with 7 mm high hex nut)		
Hex nut			45 ± 3 (65, with 7 mm high hex nut)		
Quick-release axle screw connection (axial)			33 ± 4	33 ± 4	
Quick-release axle clamp			14 ± 2	14 ± 2	
Rear wheel studs			105 ± 4	105 ± 4	
Drive unit to frame			45 – 6	45 – 6	
Centre stand/side stand to mounting block			41 ± 5	41 ± 5	
Spring strut (top and base)			53	53	
Swing arm bearing pin			7.3	7.3	
Exhaust manifold to cylinder head			21 ± 2	21 ± 2	

Engine oil viscosity chart in relation to ambient temperature

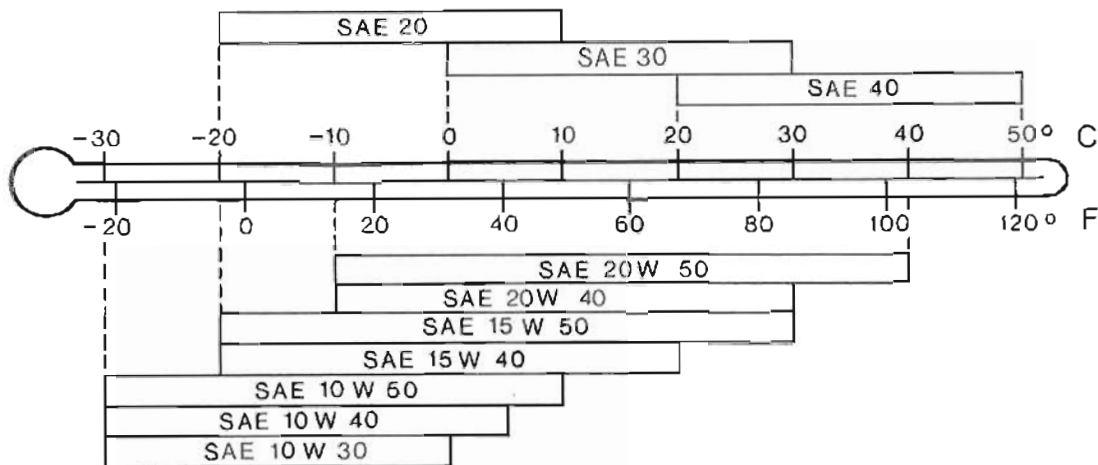

The SAE class temperature limits may be exceeded or undercut briefly.

Applicable to:

Brand HD oil for spark ignition engines, API classifications SE/CC and SF/CC

Determining engine oil consumption

Oil consumption can be measured after app. 7500 km.

The motorcycle has to travel around this distance before oil consumption stabilises.

The engine must be free from leaks.

Drain off the engine oil with the engine at operating temperature.

Renew the filter element.

Add fresh oil to the engine.

Ride the motorcycle in normal conditions until the oil level has fallen to the lower mark on the inspection window. (Difference between MIN and MAX mark = 0.60 l, determine oil consumption by volumetric measurement if appropriate.)

Measurements taken over a short distance are always imprecise, as the first half litre is always used up more rapidly.

Maximum permissible oil consumption rate: 0.15 l per 100 km.

Possible causes of excessive oil consumption:

1. The running-in process is not yet complete.
2. Valve guides leaking.
3. Piston seizure.
4. Piston rings incorrectly installed, broken or worn.
5. Operating clearance between valve stem and valve guides excessive, valve stem seal faulty.

Engine oil – changing I, II, III

Remove oil drain plug (1) in the oil sump and drain off the engine oil at normal operating temperature.

Release retaining screws for the oil filter cover and remove the cover.

Renew the drain plug sealing ring.

Tightening torque:

Oil drain plug $18 \pm 2 \text{ Nm}$

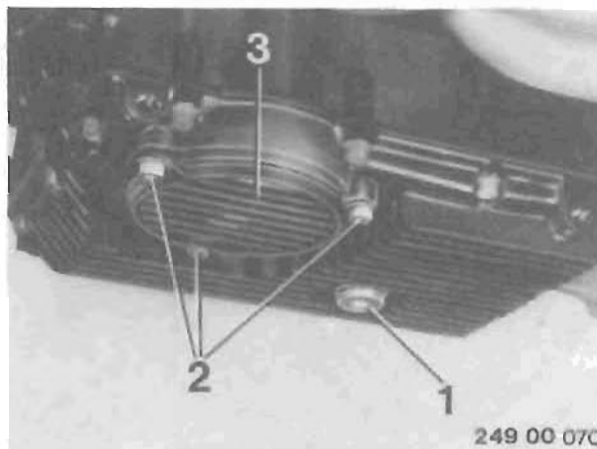

Unscrew the oil filter element with oil filter wrench BMW 11 4 650 and open-ended wrench.

When installing:

Wet the sealing ring of the new filter element with oil.

Screw in the filter element hand-tight only!

Replace O-ring seal if damaged.

Tightening torque:

Machine screw for cover/oil filter $6 \pm 1 \text{ Nm}$

Oil filling capacity: 3.75 l

Oil grades: see Service Data, page 00–29.0.

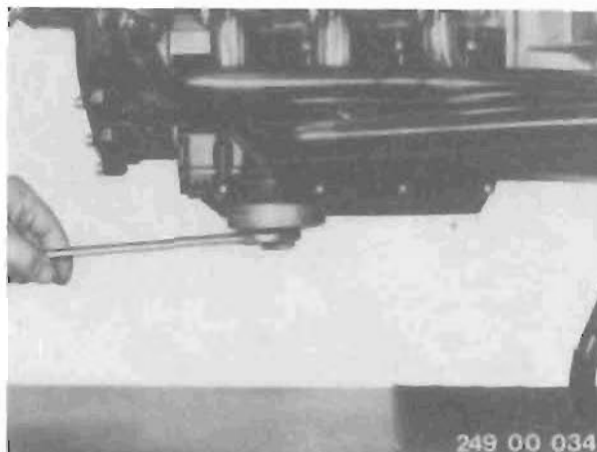

Gear oil – changing II, III

Remove oil drain plug on gearbox (arrows) and allow oil to drain out.

(Two versions: in front of and behind centre stand.)

Renew drain plug sealing ring.

Tightening torque:

Oil drain plug $20 \pm 3 \text{ Nm}$



Remove oil filler plug.

After refilling with fresh oil, check the oil level with hook wrench included in the toolkit. The oil must come up to the mark on the hook wrench.

Renew sealing ring for filler plug.

Oil filling capacity: 0.85 l

Oil grades: see Service Data, page 00–29.0

Tightening torque:

Oil filler plug $20 \pm 3 \text{ Nm}$

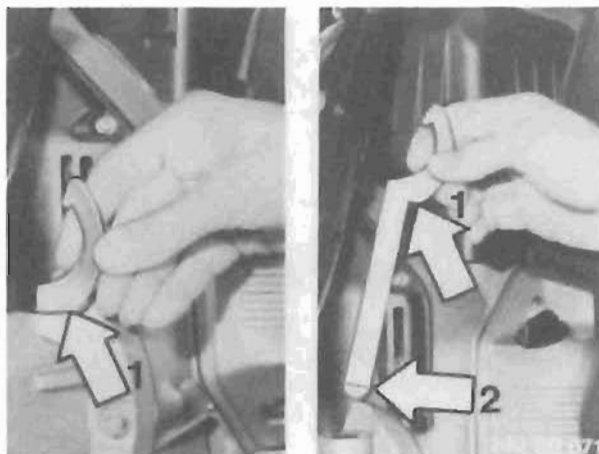

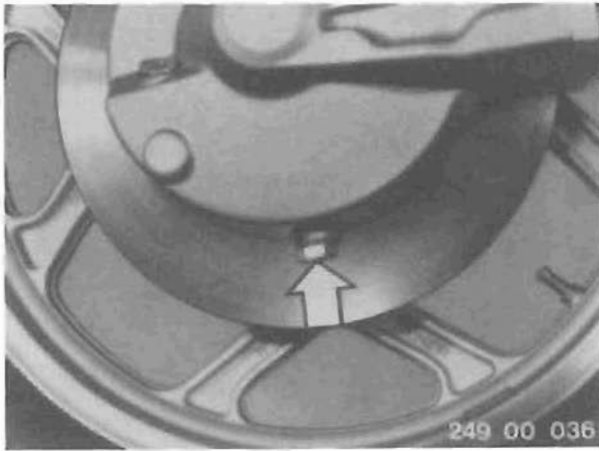

Final drive oil – changing I, III

Remove oil drain plug from final drive and drain off the oil.
Renew the drain plug sealing ring.

Tightening torque:

Oil drain plug $25 \pm 3 \text{ Nm}$

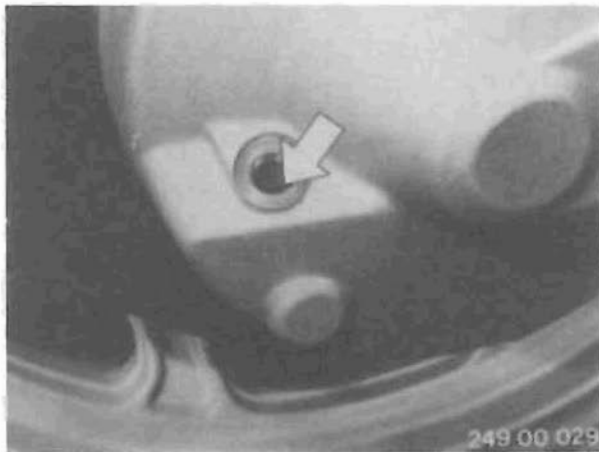

Remove oil filler plug.

After refilling with fresh oil, the oil should come up to the bottom of the thread on the filler aperture.

Renew sealing ring for filler plug.

Filling capacity: 0.26 l

Oil grades: see Service Data, page 00–29.0

Tightening torque:

Oil filler plug $20 \pm 2 \text{ Nm}$

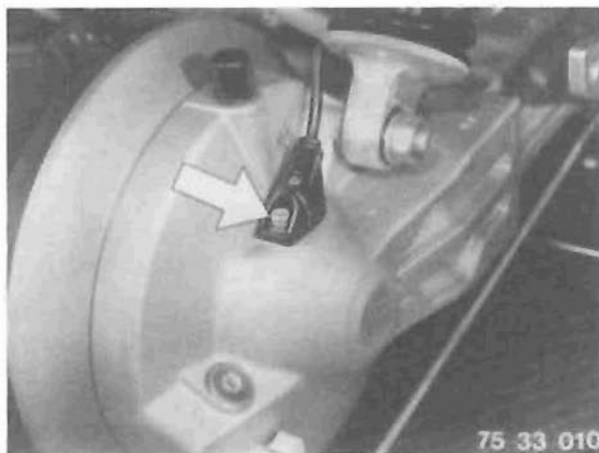

Final-drive inductive transmitter – cleaning I, III

Remove retaining screw (arrow) and pull out inductive transmitter; carefully lever out with screwdriver if necessary.

Clean inductive transmitter with cloth.

Tightening torque:

Machine screw 2.5 Nm

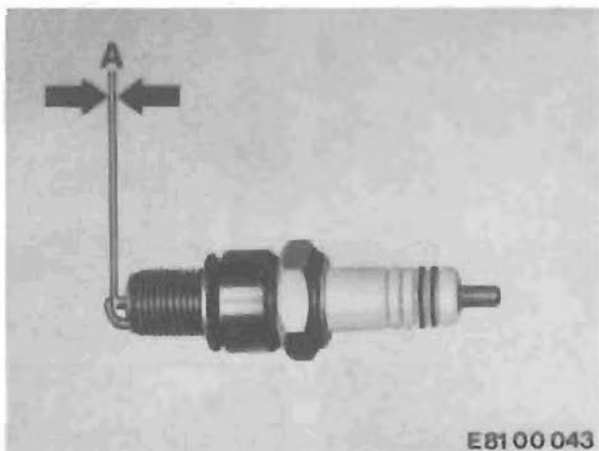

Spark plug electrode gap – checking II

Electrode gap = $0.6 \dots 0.7 \text{ mm}$

If the electrode gap is greater than 0.9 mm , renew the spark plug.

Warning

Do not bend down the spark plug electrode, as this could cause it to break off during operation, resulting in engine damage.

Determining state of engine from spark plug appearance

The colour and nature of deposits on the spark plug and insulation reflect the engine's condition and the combustion pattern.

Spark plug: normal

Insulator base light grey to fawn.

The spark plug's thermal value is correct and the engine in good condition. No faults in ignition and fuel injection system.



Spark plug: sooted

Spark plug coated in soft, dry soot deposits.

Potential causes: mixture too rich, air filter contaminated, spark plug too cold (wrong thermal value).



Light (white)

Electrode and insulator a snowy white colour.

Potential causes: mixture too lean, incorrect ignition timing (too early), deposits in combustion chamber, spark plug too hot (wrong thermal value).



Oily

Electrodes and spark plug interior coated in a black oily film.

Potential causes: oil in combustion chamber, piston ring gap too large, score marks in cylinder, valve stem seal leaking, excessive valve stem play in valve guides.



Spark plugs – renewing III

The spark plugs should be changed after a distance of 15 000 km, as the interior electrode burns down to a ball shape and adversely affects sparking behaviour.

Only use approved brands.

Service data: see page 00–29.0

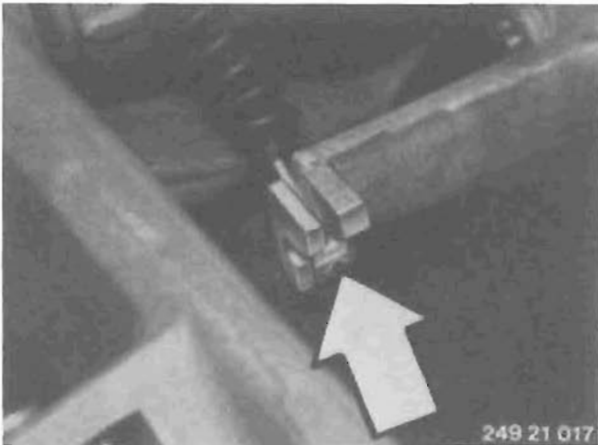

Clutch cable nipple – greasing II, III

Disconnect the clutch cable at the clutch release arm (arrow) and then at the lever. Grease the nipple (e.g. with Shell Retinax A).

Clutch play – checking, adjusting I, III

To ensure perfect functioning of the clutch and its operating mechanism, the basic setting and lever play must match.

To check the basic setting, disconnect the clutch cable on the clutch release arm.

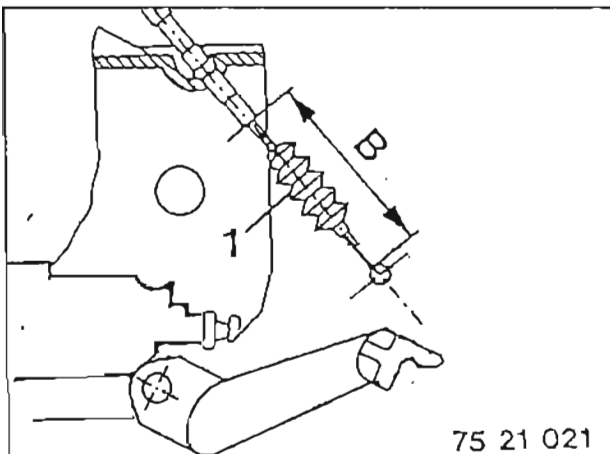

Basic setting:

Push back grommet (1) slightly and adjust dimension B to 75 ± 1 mm at the clutch lever adjusting screw (see next illustration) with BMW adjusting gauge 21 3 500.

Slacken off knurled nut (1) on adjusting screw on the clutch lever and turn the adjusting screw (2) until dimension B is obtained.
Connect clutch cable up to release arm again.

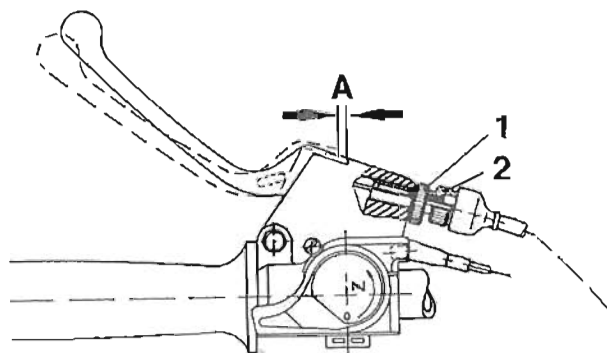

75 21 020

Slacken off locking nut (1).
Slacken adjusting screw (arrow) through one to two revolutions, tighten slowly until resistance is felt and then secure with locking nut (1).

After obtaining basic setting, adjust clutch lever play to dimension A at adjusting screw and secure with locking nut.

Warning:

Adjust for wear only at the screw on the release arm.

 A = 2 + 0.5 mm

 A = 4 + 0.5 mm

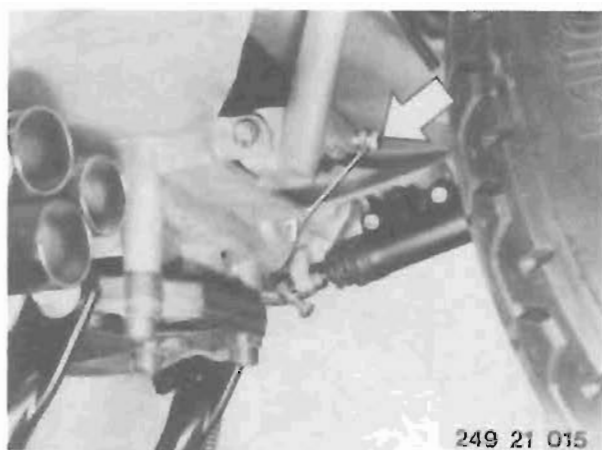

249 21 015

Valve clearance – checking, adjusting I, II, III

K 100 RT: remove lower fairing on left, as for removing and installing air cleaner (page 00–36.0).
The cam on the valve to be measured must be in contact with the tappet on the base circle, i.e. the cam tip points towards the mechanic.

Determine clearance with a feeler gauge.

Valve clearance measured at max. 35°C engine temperature

Inlet	0.15 ... 0.20 mm
Exhaust	0.25 ... 0.30 mm

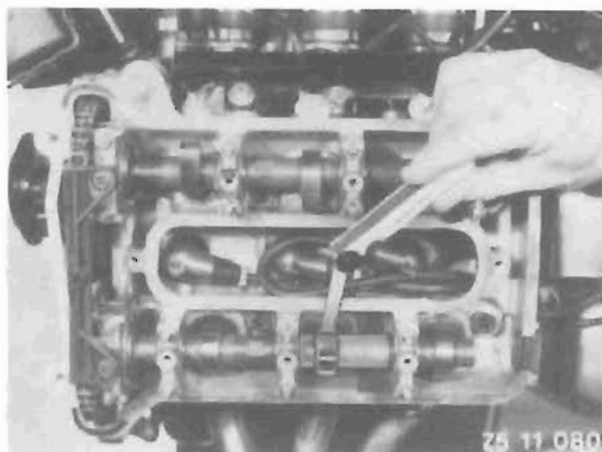

75 11 080

To change the adjusting plate, turn the bucket-type tappet until the groove points inwards through app. 45° (arrow).

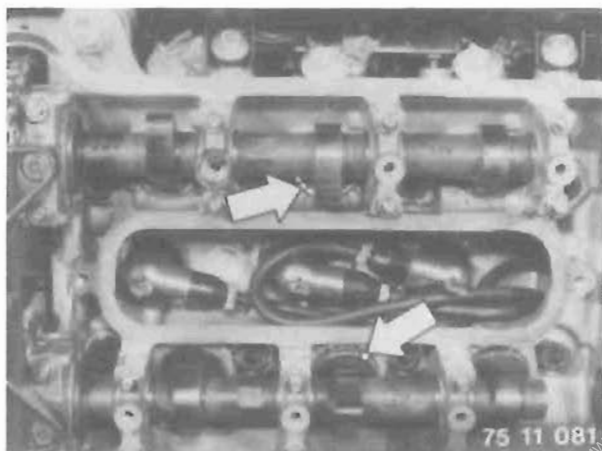

75 11 081

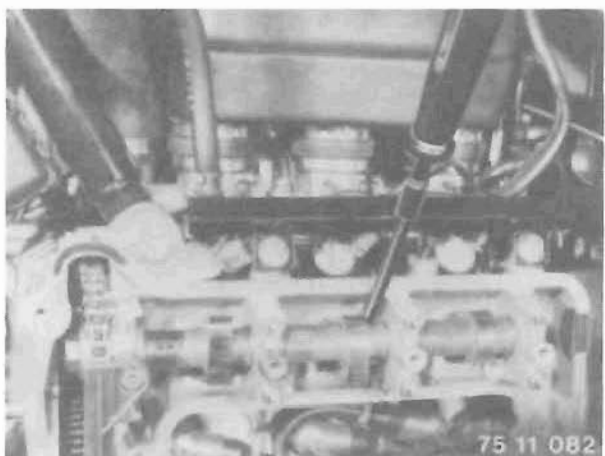

Push the bucket-type tappets down with BMW holding-down tool 11 1 720.

Note:

Apply the holding-down tool and push outwards so that it presses against the adjusting plate (avoid pressing the tappet unevenly as it may otherwise become tilted).

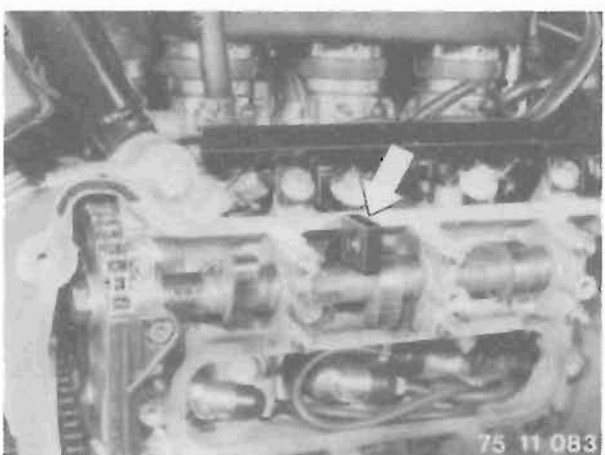

Apply spacer, BMW 4 1 722, at the edge of the bucket-type tappet (adjusting plate can be moved) and remove the holding-down tool.

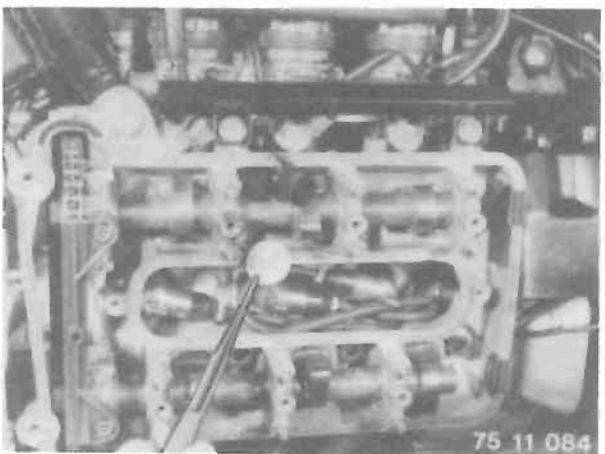

Insert special pliers, BMW 11 1 730, through the groove in the bucket-type tappet, grip the adjusting plate from beneath and remove it sideways.

Note:

Whenever the valve clearance is adjusted, the throttle butterfly stub assembly must be synchronised (see page 13-07.0).

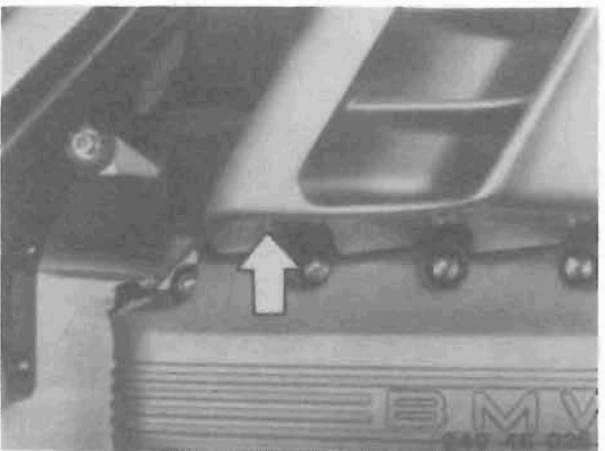

Air cleaner element – removing and installing III



K 100 RS

Remove the retaining screw (arrow) for right-hand knee pad at the base on the right-hand side.

K 100 RS

Remove the upper retaining screws (arrows) and take out the knee pad.

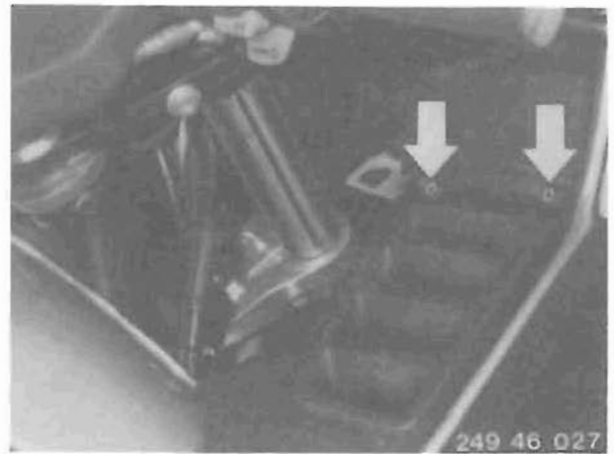

K 100 RS

Remove the retaining screws (arrows) for the lower fairing on the right in the centre of the radiator trim.

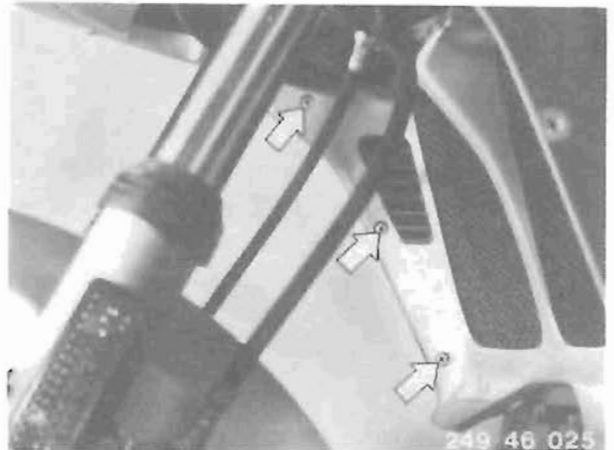

K 100 RS

Remove retaining screw (arrow) on engine block mounting, crankshaft end.

The illustration shows the cylinder head end.



K 100 RS

Remove the retaining screws (arrows) for lower fairing on right and take off lower section.

Illustrated: left-hand side.

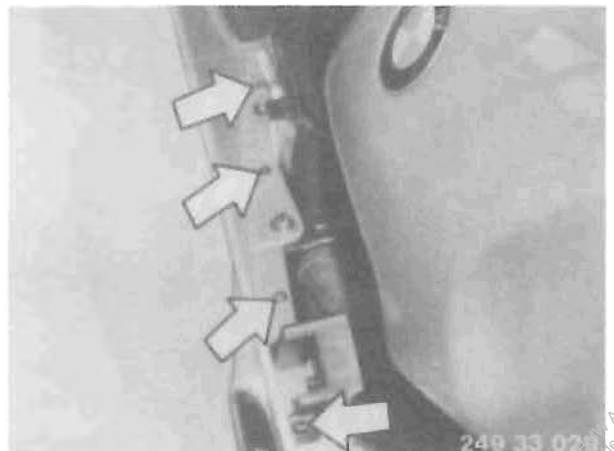

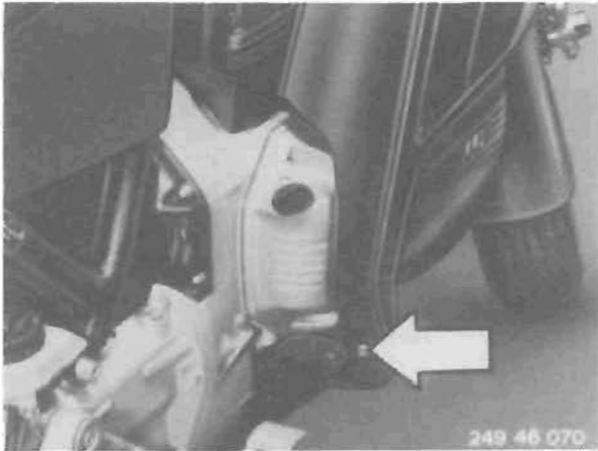

K 100 RT

Remove retaining screw (arrow) for knee pad on crankcase cover.

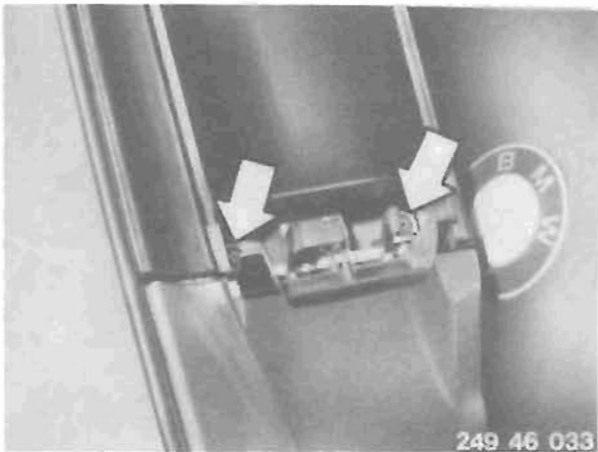

K 100 RT

Take off storage compartment cover and remove retaining screws (arrows), take off knee pad.

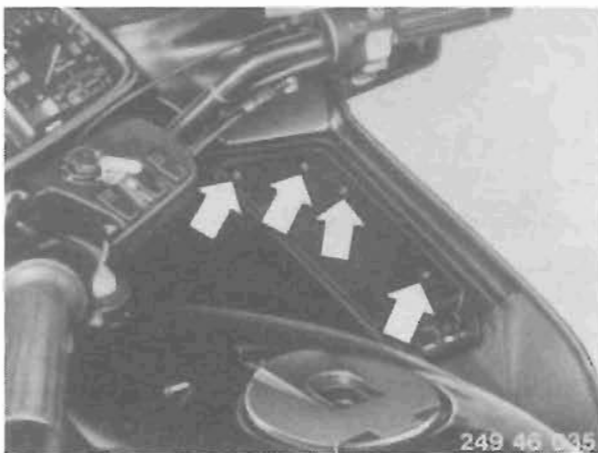

K 100 RT

Remove retaining screws on storage compartment (arrows) and take out storage compartment.

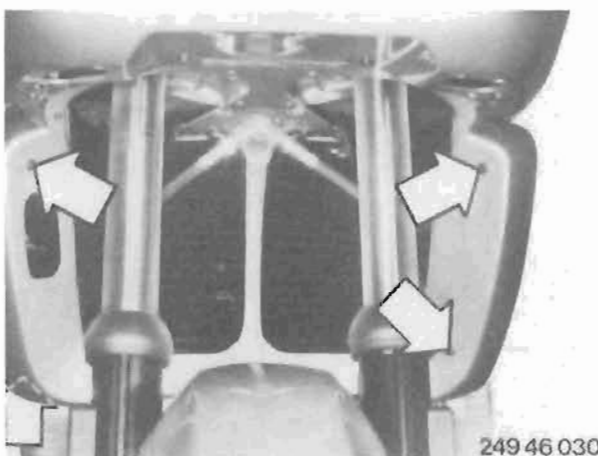

K 100 RT

Remove retaining screw (arrow) for side section in radiator trim.

K 100 RT

Remove retaining screws (arrows) for partition and side section.



K 100 RT

Pull partition section off upper holder.
Remove retaining screws (arrows) for lower fairing section on engine block and take off lower section.

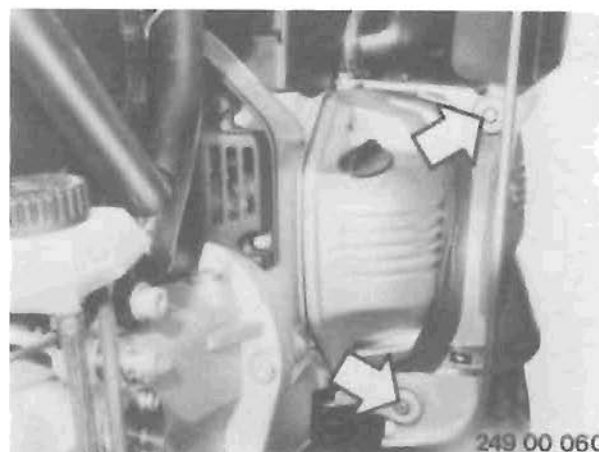

Pull out intake air line on air cleaner housing and pull off intake pipe.

When installing:

To simplify installation, grease the intake air line slightly at the base.



Remove retaining clips (arrows) on air filter housing; front clip opens from bottom to top.

(For greater clarity, the picture shows the engine removed.)

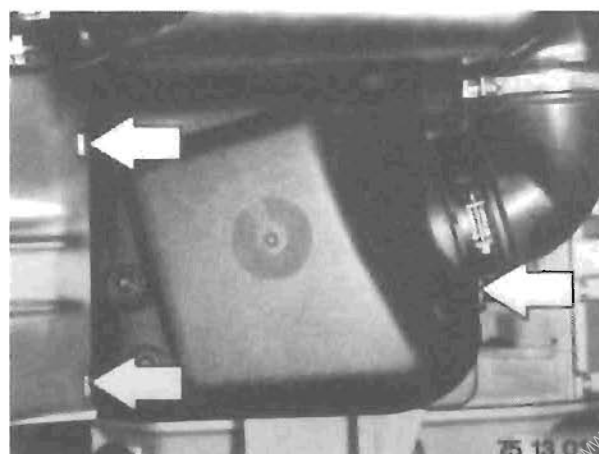

Offer up top section of air cleaner housing to collector and push against collector. Take out air cleaner element.

When installing:

Ensure that the lugs are correctly located when installing, in particular at the collector end. Ensure that the end marked "TOP" is at the top; the lettering must point towards the rear (rear wheel).

Install in the same order but according to the reverse procedure.

Cable play (throttle, increased starting speed) – checking, adjusting if necessary I, III

K 100 RS and RT: remove lower fairing section as in procedure for removing and installing air cleaner, page 00–36.0.

Throttle actuator



Adjust throttle cable play to 1 mm at adjusting screw on steering fitting at full right-hand lock.

Note:

When the throttle twistgrip is first turned, the throttle butterfly must first be heard to click.

Increased starting speed

The gap at the idle speed stop screw is adjusted for choke lever position 1 at knurled screw (1) and for choke position 2 at stop screw (2).

Gap		
Stage 1	1.5 mm	1.0 mm
Stage 2	3.0 mm	2.5 mm

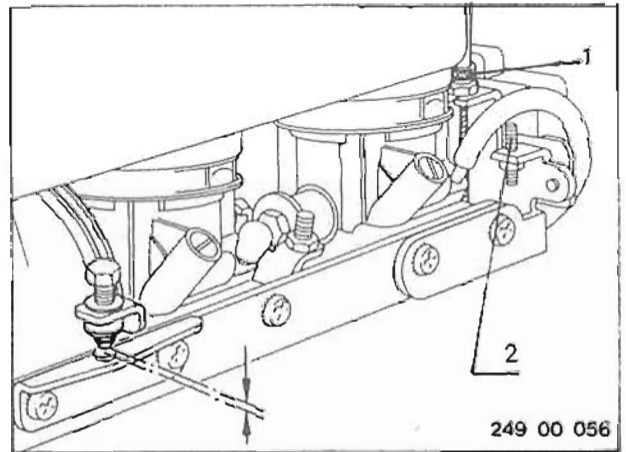

Idle speed – checking, adjusting if necessary I, II, III

K 100 RS and RT: remove lower fairing section on left, same procedure as when removing and installing air cleaner, page 00–36.0.

Only adjust idle speed with the engine at operating temperature (85°C).

Pull off stoppers on vacuum connections (arrows) and line on pressure regulator (1).

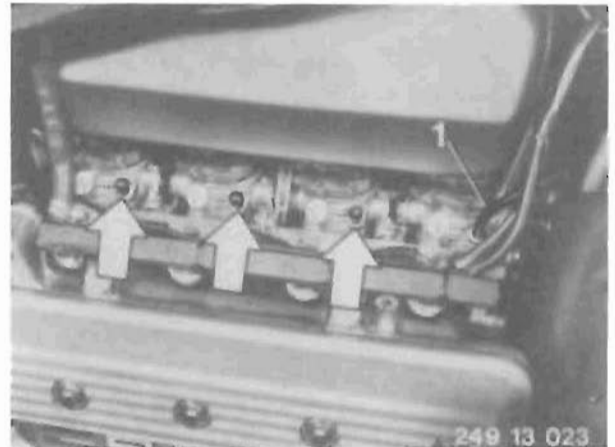

Connect up BMW synchronous tester 13 0 700 with adapter section BMW 13 0 702 to vacuum bores (arrows).



to cylinders 1 and 2



(illustrated): to cylinder 1, 2 and 3

Pull line (2) off pressure regulator and fit BMW adapter piece 13 0 703 to pressure regulator and line (2) to T-section on adapter.

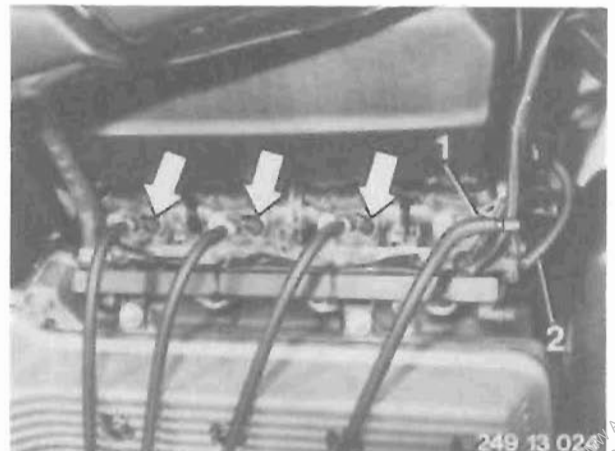

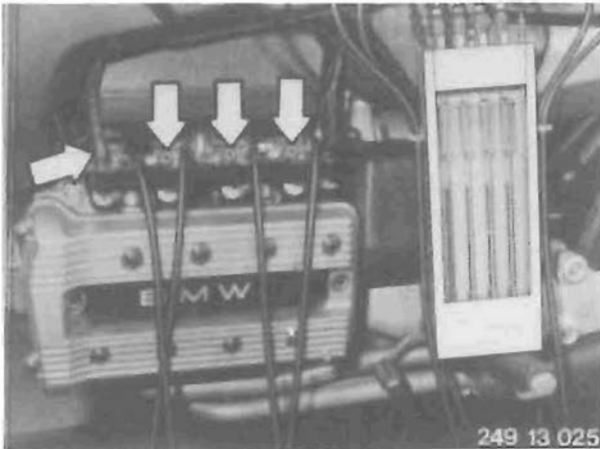

Turn the individual recirculated air screws (arrows) clockwise or anticlockwise to synchronise operation of each cylinder, i.e. the three or four mercury columns must all show the same level.



Adjust idle speed at idle speed adjusting screw (arrow). Idle speed $950 \pm 50 \text{ min}^{-1}$

Note:

When starting to turn the throttle twistgrip, a click must be clearly heard; if not, the idle speed adjusting screw has been screwed in too far.

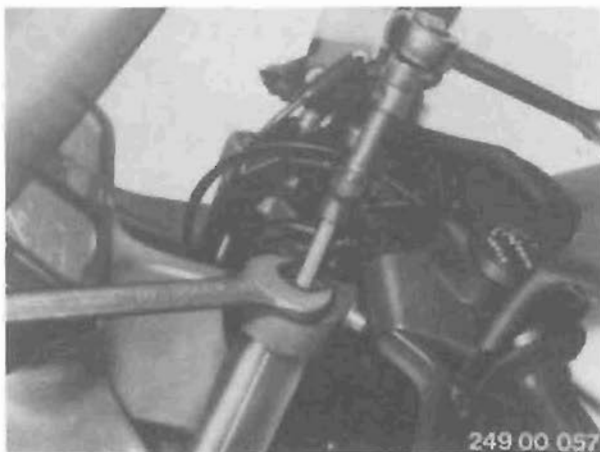

Oil in telescopic fork – changing I, III

Remove stop cap with screwdriver

Remove filler screw with Allen key, prevent from turning with open-ended wrench if necessary.

Note:

K 75 c, K 75 s and K 100 RS: remove retaining screws for impact plate, slacken off handlebar mounting and turn handlebar to the rear.

Tightening torque:

Handlebar mounting

$16 \pm 2 \text{ Nm}$

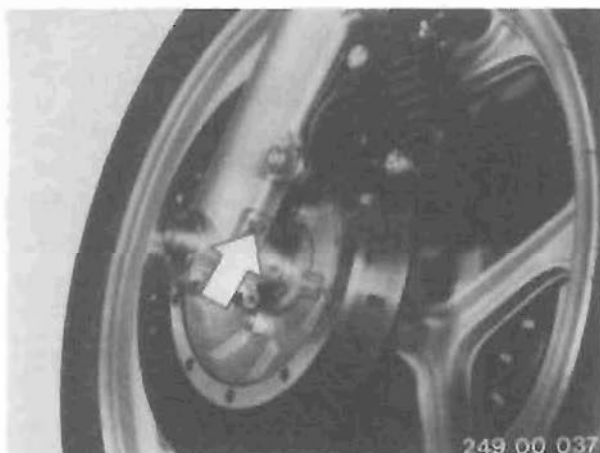

Remove oil drain plug (arrow) in sliding tubes on both sides and allow oil to drain out.

When no more oil drains out, remove the motorcycle from the supports and compress the front fork several times.

Place the motorcycle on its supports again and raise with BMW hoist 00 1 510 until the front wheel is just off the ground.
When the remaining oil has drained out, screw in the drain plugs again.

Renew the sealing rings!

Tightening torque:

Drain plug 9 ± 1 Nm

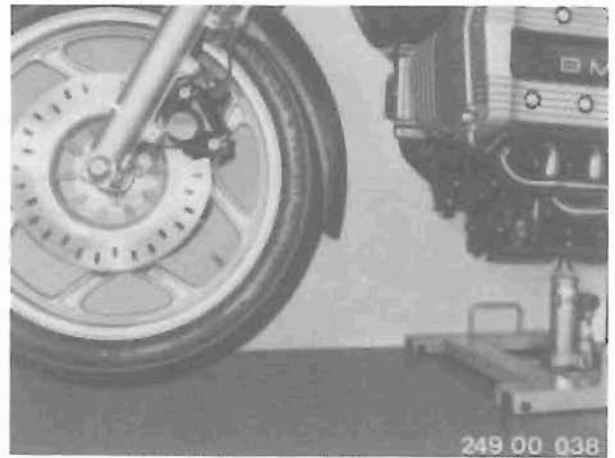

Refill with measuring beaker and funnel (with extension hose).

Filling capacity per tube:

K 75, c, s, K 100 $0.33-0.01$ l

K 100 RS, RT $0.36-0.01$ l

Sports settings $0.28-0.01$ l

Insert oil filler plugs with new sealing rings and tighten, then lower the front wheel again (air cushion in fork).

Tightening torque:

Oil filler plug 15 ± 2 Nm



Steering head bearing play – checking, adjusting if necessary III

Place motorcycle on supports and raise with BMW hoist 00 1 510 until the front wheel is off the ground.

The handlebar must slowly fall away from the centre position to the left or right stop.

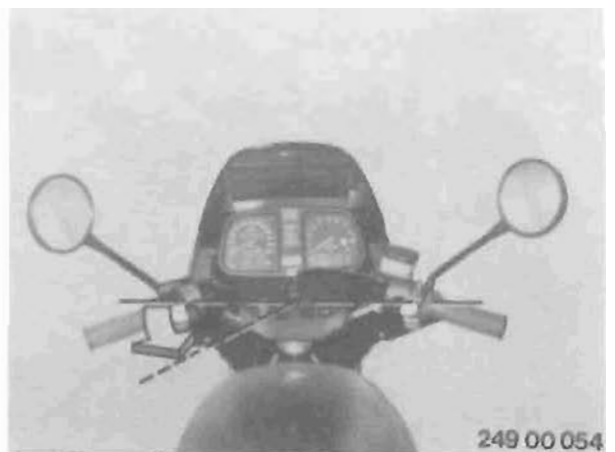

Note:

Remove the rubber sleeves on K 100 RS and RT on the fairing, as these falsify the frictional value.

Slacken off the taper screws for the Fluidbloc.

Tightening torque:

Taper screws 9 ± 1 Nm

Remove the fuel tank to adjust the steering head bearing. See Group 16.



Remove impact plate.
Lever off ignition lock marker plate.
Push retaining hook for ignition lock inwards and push the ignition lock down to remove.
Remove retaining screws (arrows) and take off impact plate.

Note:
If additional switches are fitted, place the impact plate on the instrument cluster.

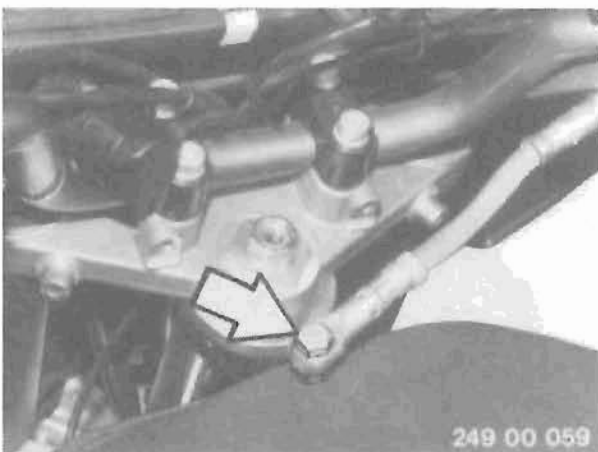

Remove the brake line hollow retaining screw (arrow) on the distributor pipe.

Note:
Stop the brake line with screw (arrow) and seal rings.

Warning:
Brake fluid attacks paintwork.

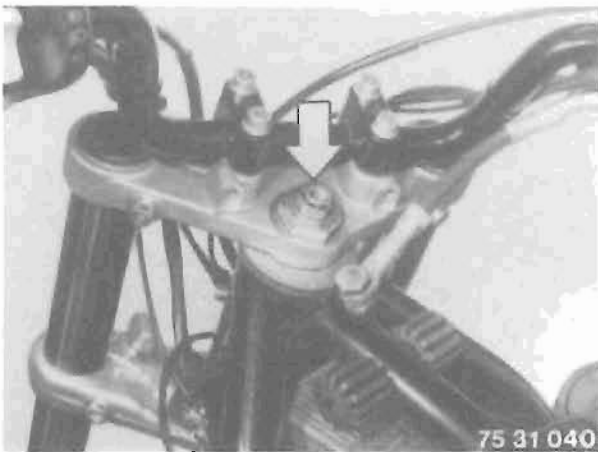

Slacken off hex nut (1) and locking pipe (arrow). Adjust steering with circular nut. Tighten the circular nut if play is excessive; slacken the circular nut if steering is too stiff.

Before checking again, tighten locking tube (arrow) and hex nut (1).

Tightening torque:

Locking tube with 5 mm hex nut	$45 \pm 3 \text{ Nm}$
Locking tube with 7 mm hex nut	$65 \pm 4 \text{ Nm}$

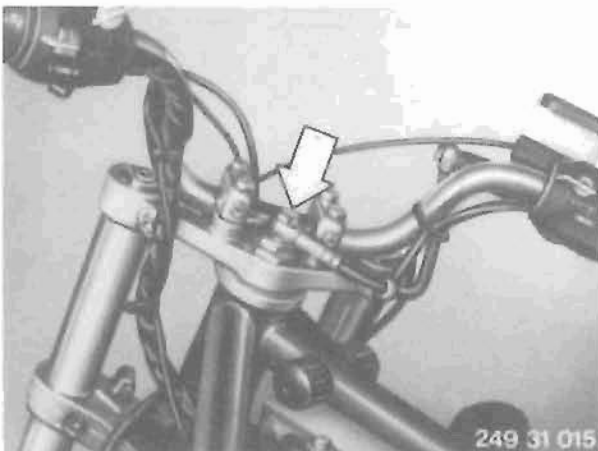

Secure brake line to distributor pipe with steel screw (arrow).

Renew sealing rings.

Tighten taper screws for Fluidbloc.
Install impact plate.

Tightening torques:

Hollow screw	$7 \pm 1 \text{ Nm}$
Taper screw	$9 \pm 1 \text{ Nm}$



Slacken off plastic nut (1) and stop screw (2). If steering play is excessive, tighten circular nut (arrow); if it is too stiff, slacken the circular nut.

Tighten stop screw (2) with BMW special wrench 31 4 860 before checking again.

Tightening torque:

Stop screw	$74 \pm 5 \text{ Nm}$
Plastic nut	$10 \pm 1 \text{ Nm}$

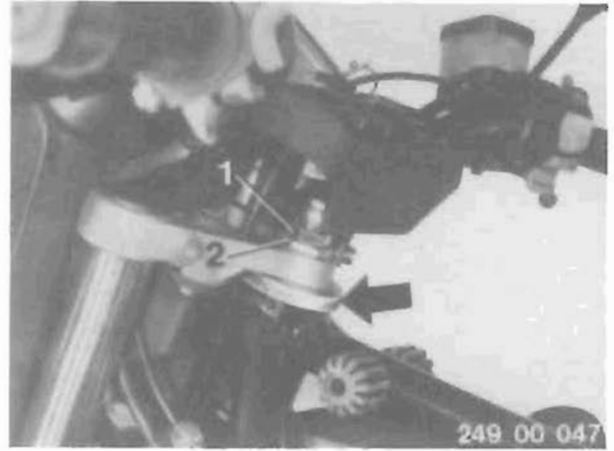

Fuel filter – renewing III

Remove retaining screws (arrows) for fuel filler stub pipe and take out pipe.

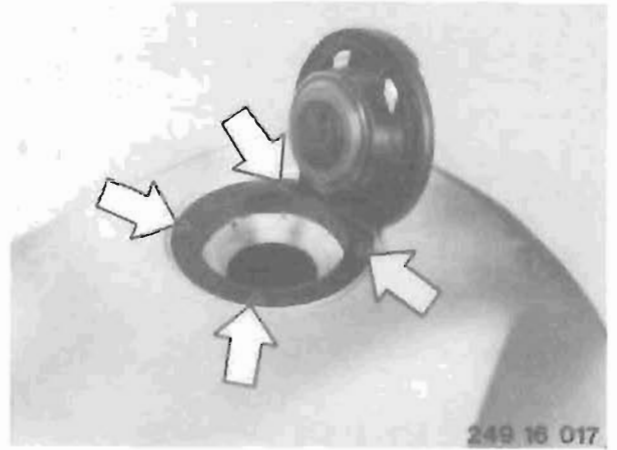

Remove hose connector (arrow) on pressure line (illustration shows cutaway model).

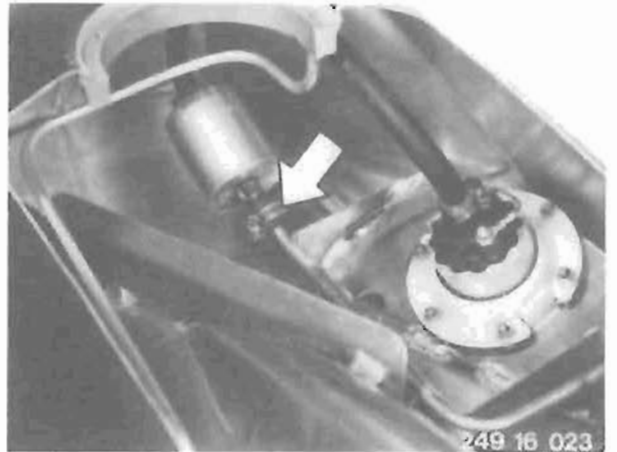

Take filter element together with pressure line out of the filler pipe.

Remove filter element.

When installing:

Note direction of fuel flow (indicated on filter housing).

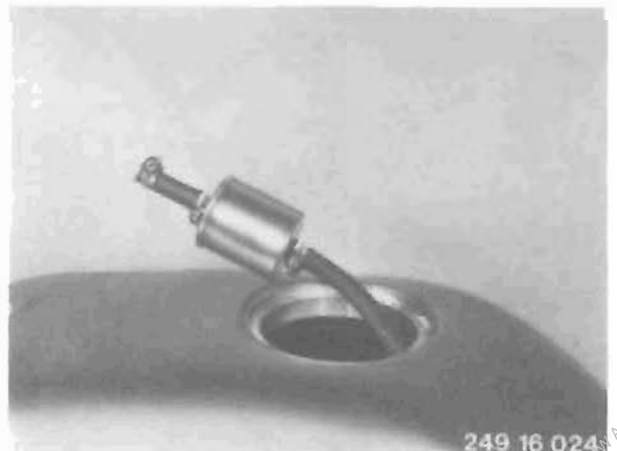

Brakes – checking I, III

Check the brake lines for damage and also for correct location.

Dry all screw connections on the brake lines.

Apply the brakes with force and hold in position for a certain time. Then check the brake system for any leaks.

Examine brake pads and discs for wear, and renew if necessary. III

For safety reasons, the brake pad thickness on the backing plate must not be allowed to fall below 1.5 mm.

Brake fluid – changing I, III

Brake fluid must be changed annually.

Brake fluid is exposed to high thermal loads (fluctuating loads), as a result of which the natural ageing process is accelerated. Due to its hygroscopic properties, moisture is absorbed from the atmosphere and the boiling point can fall to a dangerously low level.

Important:

*Do not allow fluid to come into contact with the body paintwork, as brake fluid **attacks** paint.*

Change the brake fluid with the aid of a brake filling and bleeding device (e.g. Joma 2 L).

Illustration: front brake.

Remove cover for brake fluid tank and take out the diaphragm.

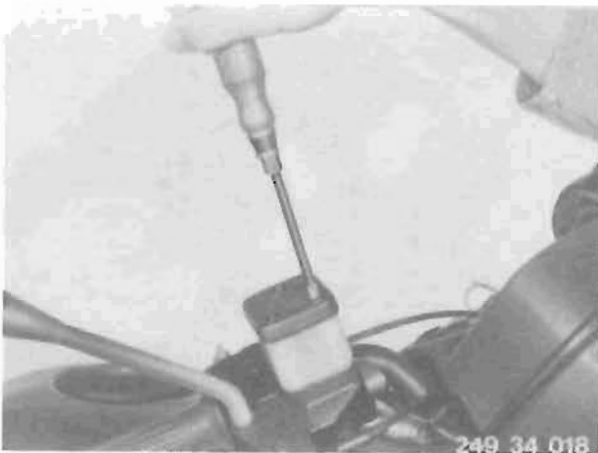

Screw the appropriate adapter (arrow) on to the brake fluid tank and connect up the hose.

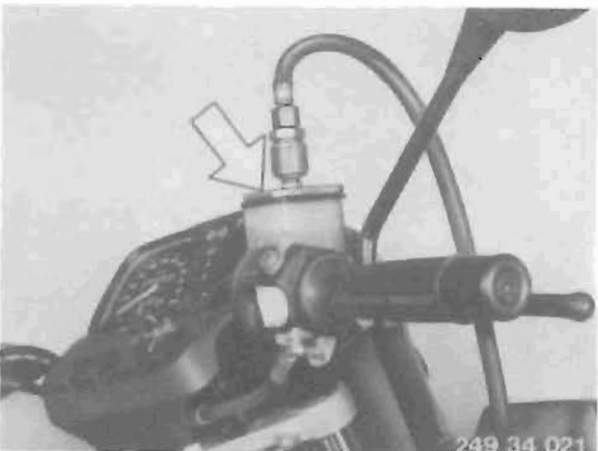

Carefully lever off the brake caliper cap. Drive out retaining pins (1) and (2) from the side facing the wheel (arrows) with an arbor.
Take out the spring and clamping pins.
Pull out the brake pads (e.g. with wire hook).

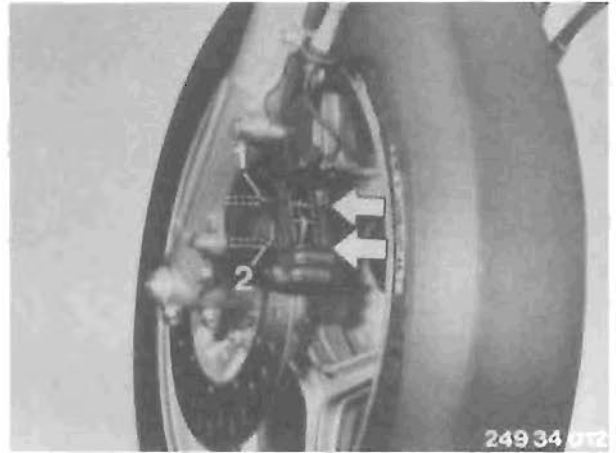

Insert the piston setting-back device, BMW 34 1 500, in the brake caliper and push back the piston into the brake caliper with an adjusting screw.
Only in this way is it possible to change the brake fluid behind the piston.

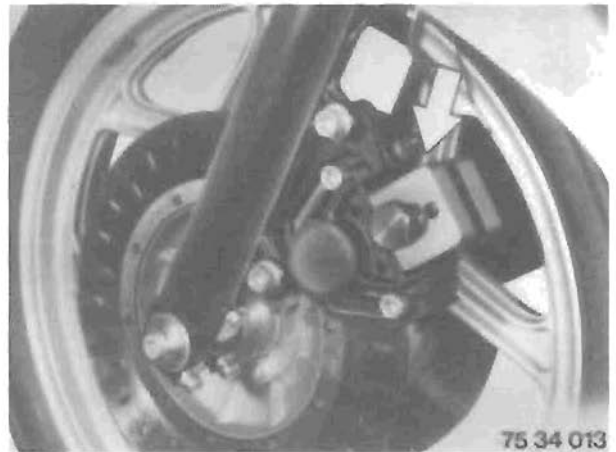

Take out the piston setting-back device and substitute with spacer, BMW 34 1 510, to hold the piston back in the brake caliper.

On twin disc brakes, insert the piston setting-back device in the second caliper and push back the piston.



Set the lever on the bleeding device to "Compressed-air operated". Connect up the line from the overflow tank to the brake caliper bleed screw (arrow), open the bleed screw with an open-ended wrench and allow all the brake fluid to drain out (perform this procedure at both brake calipers).



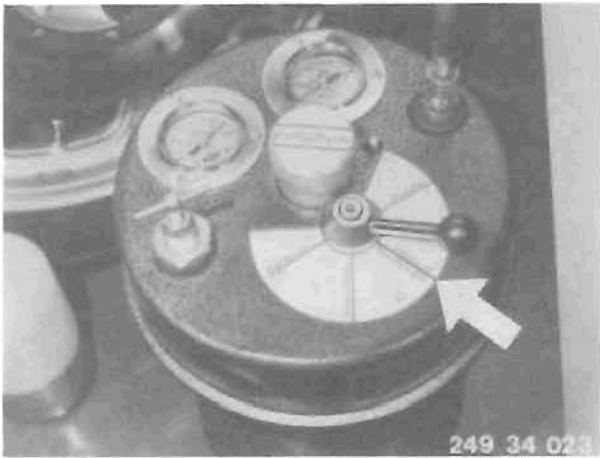

Set the lever on the bleeding device to "Brake-fluid operated". Leave the bleed screw on the brake caliper open until only brake fluid comes out (no air bubbles). (Carry out procedure at both brake calipers.)

Remove piston setting-back device and spacer.

Re-install brake pads, ensuring that the retaining pins, spring and clamping pins are properly located. Press the cap back on.

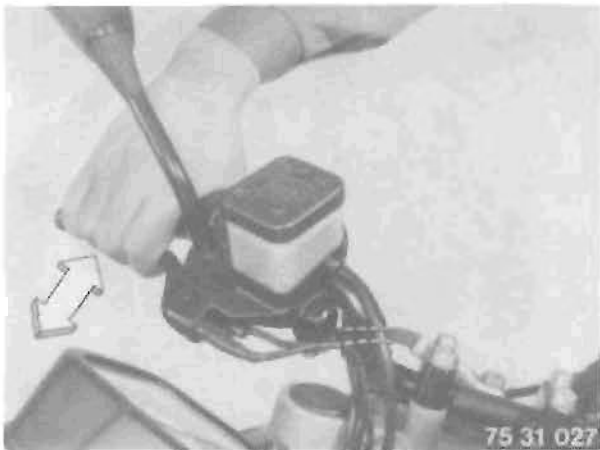

Set the lever on the bleeding device to "Pressure relief". Swing the handlebar between the left and right lock limits, applying the handbrake several times.

Any air will escape via the main brake ram and the pressure point will be achieved.

Pull hose off adapter plate.

Remove adapter plate.

Adjust brake fluid level (fill up to "MAX" level).

Fit cover on diaphragm and tighten retaining screws.

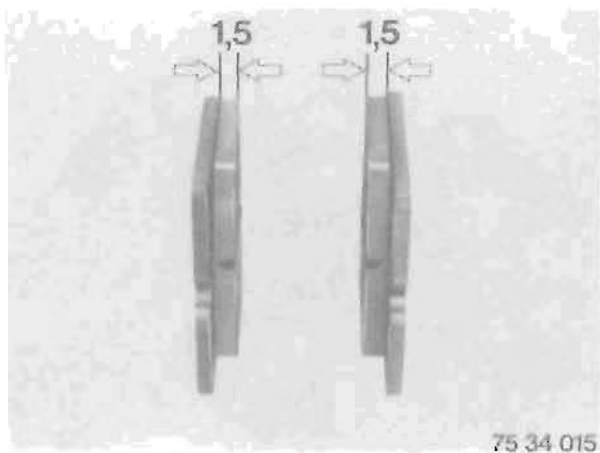

Examine brake discs for score marks and any cracks. Renew the disc if any distinct scores can be felt or seen.

Minimum brake disc thickness 3.6 mm

Brake disc – removing and installing:

Front, see Group 34

Rear, see Group 34

Battery acid level – checking III

Examine battery acid level and top up to "MAX" with distilled water if necessary.
Check battery charge with hydrometer.
Grease the battery terminals with acid protection grease (e.g. Bosch FT 40 V1).

Coolant concentration – checking I, III



Remove battery trim on right, as illustrated.

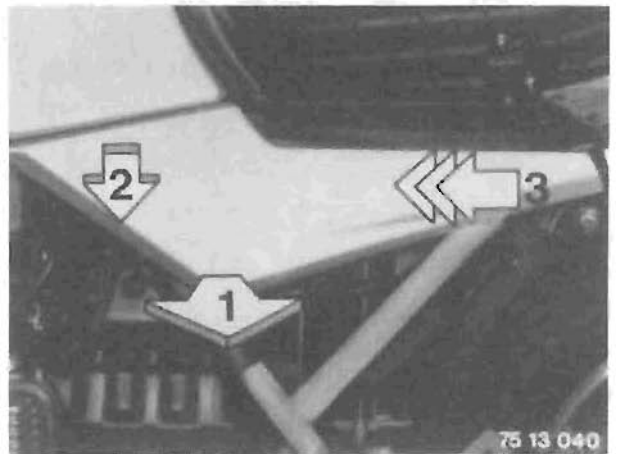

Remove battery trim on right, as illustrated.

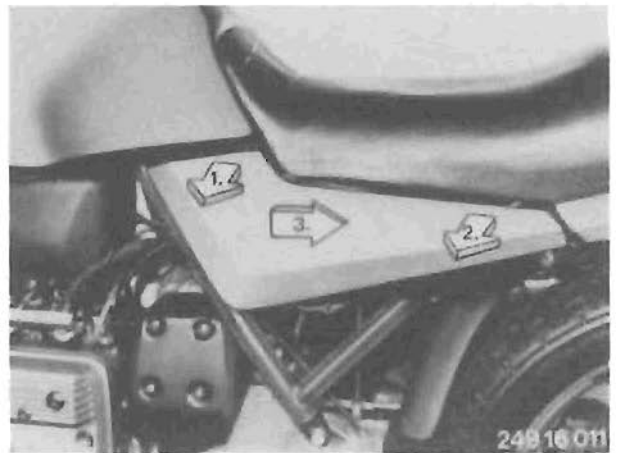

From frame No.:

- K 100 – 0008131
- K 100 RS – 0084625
- K 100 RT – 0027888

Remove battery trim on right, as illustrated.

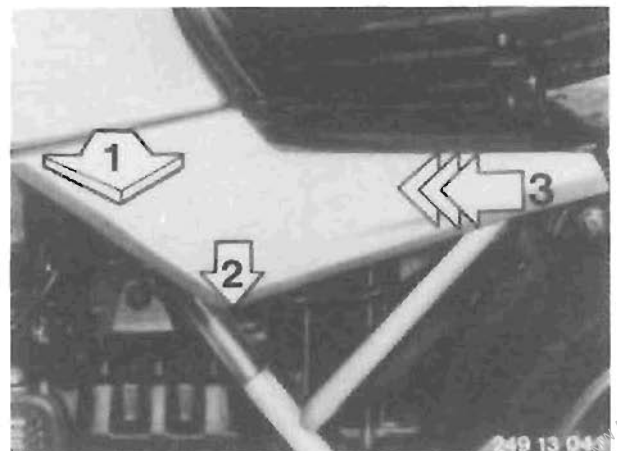

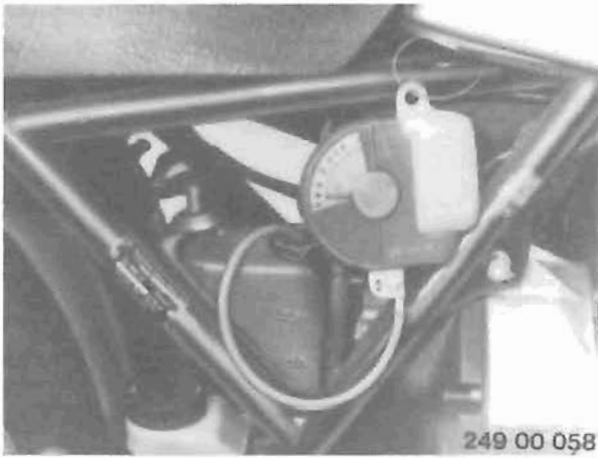

Draw coolant out of equalizer tank with a suitable measuring device (e.g. Glycomat). The device directly displays the antifreeze protection limit in °C.

Normal concentration 40 : 60, down to -28°C (40% antifreeze : 60% water)

Scandinavian countries: 50 : 50

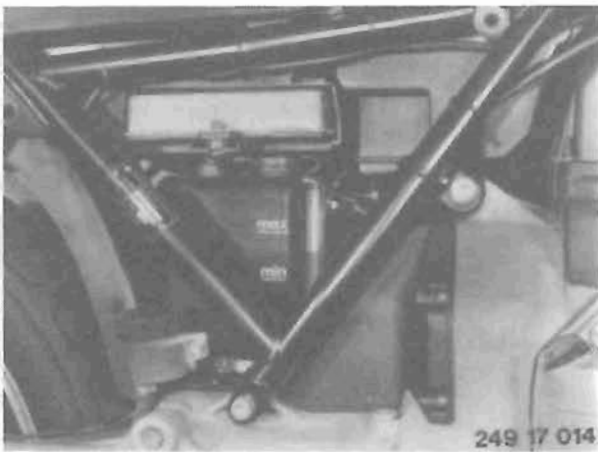

Coolant should only be added to the equalizer tank, and with the engine cold (ambient temperature).

When the engine is cold, the cooling system is under a slight vacuum to ensure that coolant flows from the equalizer tank into the radiator.

The equalizer tank must be filled to between "MIN" and "MAX".

Never fill to above "MAX".

Only use approved grades of antifreeze.

Change coolant at least every 2 years.



2.5 l



2.8 l

+ 0.4 l in equalizer tank in each case.

Check hose connections in fuel and radiator systems for leaks.

Ensure that hose clips are securely attached; tighten if necessary.

Free travel at brake pedal (drum brake) – checking, adjusting if necessary III

There should be about 25 mm brake pedal play (L). Adjust the brake light switch with adjusting screw (arrow) so that the brake light comes on at the latest when the brake pads make contact.

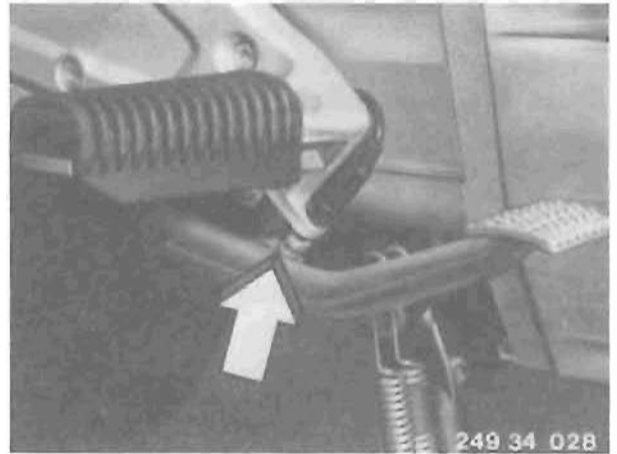

Footbrake lever – adjusting

Screw in wing nut on brake linkage until the rear wheel is braked. Correct play of app. 25 mm is obtained by unscrewing the wing nuts again by 3 ... 4 turns.

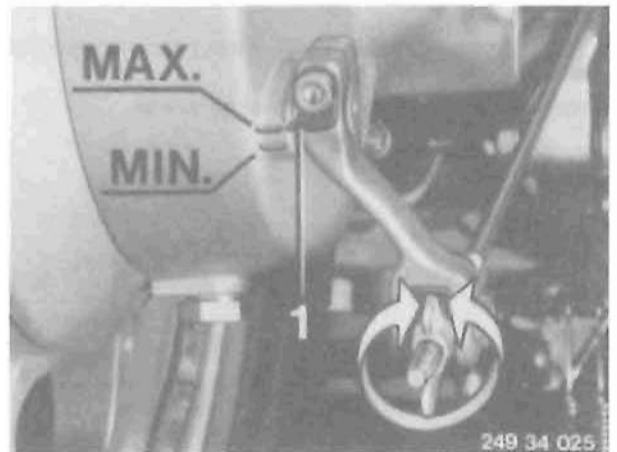

Screws and nuts – taking up slack I, III

All screw connections which are vital to the motorcycle's safety must regularly be tightened to the specified tightening torque.

Tightening torques for:

Rear wheel studs	105 ± 4 Nm
Spring strut mounting screws	51 ± 3 Nm
Frame to driveline	45 ± 6 Nm
Machine screw in quick-release axle	33 ± 4 Nm
Clamping screws for quick-release axle	14 ± 2 Nm

Final check, including for road and functional safety I, II, III

Check vehicle and indicator lights

- High-beam and dipped headlight, parking lights;
- Brake and licence plate lights, turn indicators;
- High-beam headlight, battery charge, neutral and oil pressure telltales;
- Rear light monitor;
- Horn;
- Functioning of any special equipment options, if fitted.

Functional check

Functioning of clutch, gear shift, steering, footbrake and handbrake
 Engine neutral setting (at operating temperature)

Idle speed setting: page 00–41.0

Idle speed: $950 \pm 50 \text{ min}^{-1}$

Check engine, gearbox, final drive, brake lines and fuel system for leaks.

Check tyre pressures at front and rear

Tyre pressure (bar)
 – tyres cold

	Speed	V tyres				VR tyres			
		Solo		With pillion		Solo		With pillion	
		front	rear	front	rear	front	rear	front	rear
K 75, K 75c		2.0	2.50	2.30	2.90	–	–	–	–
	no limit	2.25	2.50	–	–	–	–	–	–
	up to 180 km/h	–	–	2.25	2.70	–	–	–	–
K 75 s	over 180 km/h	–	–	2.70	2.90	–	–	–	–
K 100, K 100 RS, K 100 RT	no limit	2.25	2.50	–	–	2.55	2.80	–	–
	up to 180 km/h	–	–	2.25	2.70	–	–	2.55	3.00
	over 180 km/h	–	–	2.70	2.90	–	–	3.00	3.20

Confirm the Inspection with stamp and signature in the Rider's Handbook.









11

Engine

11 Engine

Specifications	Page	11-03.0
Tightening torques		11-11.0
Diagrams		11-13.0
Cylinder head – removing (with engine installed)		11-43.0
Crankshaft – removing (with engine installed)		11-45.0
Crankshaft – installing (with engine installed)		11-67.0
Cylinder head – installing (with engine installed)		11-78.0
Engine – removing		11-25.0
Battery – removing		11-25.0
Coolant – draining		11-26.0
Radiator – removing		11-26.0
Throttle cable on throttle butterfly stub pipe assembly – detaching		11-27.0
Clutch cable – detaching		11-27.0
Cable for increased starting speed – detaching		11-27.0
Ignition cables – removing		11-28.0
Plug connections – uncoupling		11-28.0
Exhaust system – removing		11-29.0
Driveline – removing		11-31.0
Engine stripping down		
Injector rail – removing		11-34.0
Ignition coils – removing		11-34.0
Butterfly valve stub pipe assembly with air collector – removing		11-34.0
Intake pipe/coolant pipe – removing		11-34.0
Alternator and starter – removing		11-35.0
Driver – removing		11-35.0
Clutch – removing		11-35.0
Clutch housing – removing		11-35.0
Intermediate flange – removing		11-36.0
Countershaft – removing		11-36.0
Auxiliary shaft – removing		11-36.0
Lid for water pump – removing		11-37.0
Combined water/oil pump – removing		11-37.0
Oil sump – removing		11-37.0
Oil mesh strainer and oil filter cartridge – removing		11-38.0
Crankcase lower section – removing		11-38.0
Output shaft – removing		11-38.0
Rocker cover – removing		11-39.0
Crankcase end cover – removing		11-39.0
Hall-effect transmitter – removing		11-39.0
Rotor mask – removing		11-40.0
Timing case cover – removing		11-40.0
Control case – removing		11-40.0
Camshaft – removing		11-41.0
Cylinder head – removing		11-44.0
Pistons – removing		11-44.0
Crankshaft – removing		11-44.0
Cylinder head – stripping down		11-46.0
Valve stem seals – removing		11-46.0
Valve and valve seat – regrinding		11-47.0
Valve stem seals – installing		11-48.0
Cylinder head – assembling		11-48.0
Combined water/oil pump – stripping down		11-51.0
Oil pressure switch – removing and installing		11-52.0
Pressure relief valve – removing		11-52.0
Combined water/oil pump – assembling		11-52.0

11 Engine

Pump shaft – installing	11-53.0
Intermediate flange – stripping down/assembling	11-55.0
Shaft seal ring (driver) – removing	11-55.0
Freewheel – stripping down	11-57.0
Freewheel – assembling	11-58.0
Needle roller bearing for auxiliary shaft in crankcase – removing	11-58.0
Chain tensioner – stripping down/assembling	11-59.0
Oil level sight glass – removing and installing	11-60.0
Shaft seal ring in timing case cover – removing and installing	11-60.0
Piston – stripping down	11-61.0
Piston – measuring	11-61.0
Cylinder – measuring	11-62.0
Piston – assembling	11-62.0
Small end bushing – removing and installing	11-63.0
Piston and connecting rod – assembling	11-63.0
Crankshaft pinion and rotor flange – removing and installing	11-64.0
Crankshaft bearing play – measuring	11-64.0
Crankshaft – measuring	11-65.0
Crankshaft – installing	11-65.0
Big end bearing play – measuring	11-66.0
Output shaft – stripping down 	11-69.0
Tensioning gear – stripping down 	11-70.0
Tensioning gear – assembling 	11-70.0
Output shaft – stripping down 	11-73.0
Tensioning gear – stripping down  and 	11-73.0
Tensioning gear – assembling  and 	11-73.0
Tensioning gear – shimming	11-74.0
Ball bearing with shoulder – installing	11-74.0
Assembling the engine	
Piston – installing	11-75.0
Output shaft – installing	11-76.0
Bottom section of crankcase – installing	11-77.0
Oil sump – installing	11-77.0
Cylinder head – installing	11-79.0
Camshafts – installing	11-79.0
Timing chain – installing	11-80.0
Camshaft wheels – installing	11-80.0
Chain tensioner – installing	11-80.0
Slide rail – installing	11-80.0
Valve clearance – adjusting	11-81.0
Timing case cover – installing	11-82.0
Combined water/oil pump – installing	11-83.0
Cover for water pump – installing	11-83.0
Rotor blade – installing	11-83.0
Hall-effect transmitter – installing	11-83.0
Cover for Hall-effect transmitter – installing	11-84.0
Freewheel and auxiliary shaft – installing	11-84.0
Intermediate flange – installing	11-84.0
Output shaft sealing ring – installing	11-85.0
Clutch housing – installing	11-85.0
Driver – installing	11-86.0
Alternator – installing	11-86.0
Crankcase cover – installing	11-86.0

11 Engine

Spark plugs – installing	11-87.0
Cylinder head cover – installing	11-87.0
Throttle butterfly stub pipe assembly – installing	11-87.0
Ignition coils – installing	11-88.0
Injectors – installing	11-88.0
Driveline assembling	11-89.0
Mounting for centre stand – removing and installing	11-89.0
Air cleaner housing – installing	11-90.0
Locating frame on driveline	11-90.0
Throttle cable – installing	11-91.0
Clutch cable – installing	11-91.0
Engine wiring harness – installing	11-91.0
Ignition coils – connecting up	11-91.0
Cable for increased starting speed – installing	11-92.0
Radiator – installing	11-92.0
Connections on frame wiring harness	11-93.0
Battery – installing	11-94.0
Coolant – adding	11-94.0
Rear mudguard and licence plate base – installing	11-95.0
Exhaust system – installing	11-96.0
Frame fixation on driving device	11-97.0

Engine

Specifications

Model		K 75	K 75 c	K 75 s	K 100	K 100 RS	K 100 RT	K 100 LT
Type		Four-stroke inline engine, longitudinally installed, with twin overhead camshafts, liquid cooling and electronic fuel injection with fuel cutoff on the overrun						
Location of engine number		At rear right of lower engine block						
Cylinder bore	mm	67 ± 0,005						
Piston stroke	mm	70						
Number of cylinders		3			4			
Displacement acc. to German tax formula	cm ³	735			980			
Displacement, effective	cm ³	740			987			
Compression ratio		11.0 : 1			10.2 : 1			
Max. output (nominal)	kW	55			66			
		bhp			90			
– at engine speed	min ⁻¹	8500			8000			
Max. continuous speed	min ⁻¹	8600			8500			
Max. permissible speed	min ⁻¹	8700			8600			
Idle speed	min ⁻¹	950 ± 50						
Max. permissible speeds during running-in								
– up to 1000 km	min ⁻¹	4000						
– up to 2000 km	min ⁻¹	4500						
Direction of rotation		Anticlockwise, looking at ignition system						
Max. torque	Nm	68			86,0			
		kpm			8.76			
– at engine speed	min ⁻¹	6750			8000			
Compression test	good	bar	above 10.0					
	normal		8.5 ... 10.0					
	poor		below 8.5					

Engine

Specifications

Model		K 75	K 75 c	K 75 s	K 100	K 100 RS	K 100 RT	K 100 LT
Compression test procedure		1. Unscrew and remove spark plugs 2. Use a suitable compression tester with the battery fully charged, the engine at normal operating temperature and the throttle twistgrip fully open; test at starting speed						
Fuel grades		See Rider's Handbook						
Fuel consumption (ISO DIS 7860 test method)								
– at steady 90 km/h	l/100 km	4.2	4.2	4.0	5.0	4.3	4.4	4.4
– at steady 120 km/h	l/100 km	5.6	5.6	5.4	6.3	5.7	5.9	5.9
Engine lubrication: Lubricating system		Pressurized oil circuit						
Oil filter		Full-flow						
Bypass valve opening pressure differential	bar	1.5						
Oil pressure telltale comes on below	bar	0.2 ... 0.5						
Pressure relief valve opens at	bar	5.4						
Engine oil content								
– excluding filter renewal	l	3,50						
– including filter renewal	l	3,75						
Permissible oil consumption	l/100 km	0,15						
Oil pump: Type		Gear-type						

Engine

Specifications

Model	K75	K75 c	K75 s	K100	K100 RS	K100 RT	K100 LT
Valve clearances (adjust with engine cold, max. 35°C)							
– inlet valves	mm	0.15 ... 0.20					
– exhaust valves	mm	0.25 ... 0.30					
Valve timing							
at 5/100 preload and 3 mm lift							
inlet opens 5° after TDC							
inlet closes 27° after BDC							
exhaust opens 28° before BDC							
exhaust closes 5° before TDC							
Valves							
Overall lengths							
inlet	mm	111					
exhaust	mm	110.71 ± 0.1					
Valve head dia.							
inlet	mm	34					
exhaust	mm	30					
Valve stem dia.							
inlet	mm	6.975 – 0.015					
exhaust	mm	6.960 – 0.015					
Wear limit							
inlet	mm	6.950					
exhaust	mm	6.935					
Valve head rim thickness							
inlet	mm	1.5 ± 0.15					
exhaust	mm	1.5 ± 0.15					
Min. rim thickness							
inlet	mm	1.0					
exhaust	mm	1.0					
Max. valve head runout							
inlet	mm	0.03					
exhaust	mm	0.03					
Valve seat angle							
inlet		44° 30' – 20'					
exhaust		44° 30' – 20'					

Engine

Specifications

Model		K 75	K 75 c	K 75 s	K 100	K 100 RS	K 100 RT	K 100 LT
Valve seat width								
inlet	mm	1.15 ± 0.25						
exhaust	mm	1.35 ± 0.25						
Wear limit								
inlet	mm	2.50						
exhaust	mm	3.00						
Valve guide total length								
inlet	mm	45						
exhaust	mm	45						
External diameter	mm	13 ^{U6} $\begin{matrix} +0.044 \\ -0.036 \end{matrix}$						
Internal diameter	mm	7 ^{H7} $\begin{matrix} +0.015 \\ -0 \end{matrix}$						
Wear limit	mm	7.100						
Bore in cylinder head	mm	13 ^{H7} $\begin{matrix} +0.018 \\ -0 \end{matrix}$						
Repair oversize	mm	13.2 ^{H7} $\begin{matrix} +0.018 \\ -0 \end{matrix}$						
Valve stem clearance								
inlet	mm	0.025 ... 0.050						
exhaust	mm	0.040 ... 0.070						
Wear limit								
inlet	mm	0.150						
exhaust	mm	0.165						
Valve gear								
Valve actuation		Direct, by bucket-type tappets						
Camshaft drive		Pre-stretched, endless single roller chain						
Number of links		126						
Valve springs								
Wire thickness	mm	4.25						
External winding dia.	mm	29.25 ± 0.2						
Spring length, relaxed	mm	44.5						
Wear limit	mm	43.0						
Pitch direction		clockwise						
No. of active windings		4.5 ... 3.8						
Total number of windings		6.3						

Engine

Specifications

Model		K 75	K 75 c	K 75 s	K 100	K 100 RS	K 100 RT	K 100 LT
Camshaft								
Inlet camshaft		284°						
Exhaust camshaft		284°						
Guide bearing dia.	mm	30 _{g6} ^{-0.007} / _{-0.02}						
Wear limit	mm	29.95						
Camshaft bearing dia.	mm	24 _{g6} ^{-0.007} / _{-0.02}						
Wear limit	mm	23.95						
Guide bearing bore	mm	30 ^{F7} ^{+0.041} / _{+0.02}						
Camshaft bearing bore	mm	24 ^{F7} ^{+0.041} / _{+0.02}						
Radial operating clearance:								
guide bearing	mm	0.027 ... 0.061						
base bearing	mm	0.027 ... 0.061						
Wear limit								
guide bearing	mm	0.150						
base bearing	mm	0.150						
Cam pitch circle	mm	30						
Cam lift:								
inlet	mm	39.3927 ± 0.031						
exhaust	mm	39.3819 ± 0.031						
Wear limit								
inlet	mm	39.10						
exhaust	mm	39.05						
Tappets								
External dia.	mm	33.5 _{g6} ^{-0.009} / _{-0.025}						
Wear limit	mm	33.465						
Bore in cylinder head	mm	33.5 ^{H7} ^{+0.025} / ₀						
Wear limit	mm	33.615						
Radial play	mm	0.009 ... 0.050						
Wear limit	mm	0.150						

Engine

Specifications

Model		K 75	K 75 c	K 75 s	K 100	K 100 RS	K 100 RT	K 100 LT
Crankshaft:								
Width of guide bearing	mm	$23^{F8} \begin{matrix} +0.053 \\ +0.020 \end{matrix}$						
Colour coding for crankshaft stages, main bearing dia.	mm	$45 \begin{matrix} 0 \\ -0.024 \end{matrix}$	Colour mark – oilproof –		Shaft dia.	Bearing wall thickness		
			yellow	45.000 ... 44.992		1.987 + 0.006		
			green	44.992 ... 44.984		1.991 + 0.006		
			white	44.984 ... 44.976		1.995 + 0.006		
Colour coding for crankshaft stages, big end bearing dia.	mm	$38 \begin{matrix} 0 \\ -0.024 \end{matrix}$	Colour mark – oilproof –		Shaft dia.	Bearing wall thickness		
			yellow	38.000 ... 37.992		1.479 + 0.006		
			green	37.992 ... 37.984		1.483 + 0.006		
			white	37.984 ... 37.976		1.487 + 0.006		
Crankshaft main bearing dia.	mm	Basic bore $49^{H6} \begin{matrix} +0.16 \\ 0 \end{matrix}$						
Main bearing journals – radial clearance	mm	0.020 ... 0.056						
Wear limit	mm	0.110						
Big end bearing journals – radial clearance	mm	0.030 ... 0.066						
Wear limit	mm	0.130						
Crankshaft endplay in bearings	mm	0.080 ... 0.183						
Wear limit	mm	0.250						
Connecting rods:								
Big end bearing basic bore	mm	$41^{H6} \begin{matrix} +0.016 \\ 0 \end{matrix}$						
Big end bore width	mm	$22_{d9} \begin{matrix} -0.065 \\ -0.117 \end{matrix}$						
Big end bearing width	mm	$22^{D11} \begin{matrix} +0.195 \\ +65 \end{matrix}$						
Big end bearing endplay	mm	0.130 ... 0.312						
Wear limit	mm	0.400						
Distance between bore centres	mm	125 ± 0.1						

Engine

Specifications



Model		K 75	K 75 c	K 75 s	K 100	K 100 RS	K 100 RT	K 100 LT
Small end bore	mm	$20^{H7} \begin{matrix} +0.021 \\ 0 \end{matrix}$						
Permissible weight difference between connecting rods	g	± 4						
Cylinders								
Cylinder bore	mm	A 67.00 ± 0.005 B 67.01 ± 0.005						
Wear limit	mm	A 67.05 B 67.06						
Pistons								
Piston weight group, complete		+ or – stamped on piston						
Piston dia. Make: KS	mm	A 66.973 ± 0.007 B 66.983 ± 0.007						
Wear limit	mm	A 66.92 B 66.93						
Piston dia. Make: Mahle	mm	A 66.970 ± 0.007 B 66.980 ± 0.007						
Wear limit	mm	A 66.92 B 66.93						
Piston installed clearance	mm	0.015 – 0.039						
Wear limit	mm	0.130						
Piston installed direction		Arrow on crown must face in forward travel direction						
Piston rings								
Rectangular-section ring, groove 1								
Height	mm	$1.2 \begin{matrix} -0.010 \\ -0.022 \end{matrix}$						
Wear limit	mm	1.10						
Ring gap	mm	0.25 ... 0.45						
Wear limit	mm	1.50						
Ring flank clearance	mm	Mahle	KS					
	mm	0.050 ... 0.082	0.040 ... 0.072	0.013 ... 0.027				
Wear limit	mm	0.30	0.30	0.30				

Engine
Specifications

Model		K 75	K 75 c	K 75 s	K 100	K 100 RS	K 100 RT	K 100 LT
Rectangular-section ring, groove 2								
Height	mm	1.5 ^{-0.010} -0.022						
Wear limit	mm	1.40						
Ring gap	mm	0.25 ... 0.45						
Wear limit	mm	1.50						
Ring flank clearance	mm	Mahle	KS					
	mm	0.040 ... 0.072	0.030 ... 0.062	0.012 ... 0.026				
Wear limit	mm	0.30	0.30	0.30				
Penthouse-pattern chamfered ring, groove 3								
Height	mm	3.0 ^{-0.010} -0.025						
Wear limit	mm	2.90						
Ring gap	mm	0.20 ... 0.45						
Wear limit	mm	1.50						
Ring flank clearance	mm	0.020 ... 0.055						
Wear limit	mm	0.30						
Ring installed direction		with TOP marking uppermost (ring grooves 1 and 2)						
Gudgeon pins								
Diameter	mm	18 - 0.004						
Wear limit	mm	17.96						
Bore dia. in piston for gudgeon pin								
	mm	18 ^{+0.006} +0.002						
Gudgeon pin clearance in piston								
	mm	0.002 ... 0.010						
Gudgeon pin clearance in small end bearing								
	mm	0.006 ... 0.021						
Wear limit	mm	0.060						

Engine

Tightening torques

Connection	Nm
Freewheel:	
Cover/freewheel cage to auxiliary shaft gear wheel	9 ± 1
Combined water/oil pump:	
Oil pressure switch to housing	40 ± 5
Drain screw to housing	9 ± 1
Screw plug for excess pressure valve to housing	35 ± 4
Impeller to shaft: a) nut	21 ± 2
b) bolt	33 ± 4
Pump housing to crankcase	7 ± 1
Cover to pump housing	7 ± 1
Intermediate flange:	
Stop plate to intermediate flange	9 ± 1
Intermediate flange to crankcase	9 ± 1
Crankshaft:	
Pinion/rotor flange to crankshaft	50 ± 6
Crankshaft bearing cover to engine block	50 ± 6
Connecting rod:	
Connecting rod bearing cap to connecting rod	30 ± 3
+ angle of rotation	80° ± 3°
Lower section of crankcase to engine block:	
Output shaft to front of crankcase	18 ± 2
Output shaft to rear of crankcase	40 ± 5
Lower section of crankcase to outside of engine block	7 ± 1
Oil sump to lower section of crankcase	7 ± 1
Lid to oil sump	7 ± 1
Oil drain plug	32 ± 4
Cylinder head:	
Cylinder head to engine block	30 ± 4
after 20 minutes	45 ± 5
Rocker cover to cylinder head	8 ± 1
Camshaft bearing mounts to cylinder head	9 ± 1
Camshaft timing gears to camshafts	54 ± 6
Chain tensioner to engine block	9 ± 1
Slider rail to camshaft bearing mounts	9 ± 1
Timing case cover to engine block/cylinder head	7 ± 1
Hall-effect transmitter cover to timing case cover	6 ± 1
Clutch:	
Clutch flange to output shaft	
	140 ± 5
	140 ± 5, then loosen
	and tighten again to 100 ⁺¹⁴ ₋₁₀
Housing cover to clutch flange	19 ± 2
Driver to auxiliary shaft	33 ± 4
Alternator to intermediate flange	22 ± 3
Crankshaft cover to engine block	8 ± 1
Exhaust pipes to cylinder head	21 ± 2
Coolant/intake stub to cylinder head	7 ± 1
Injector rail to cylinder head	7 ± 1
Gearbox to intermediate flange	16 ± 2
Spring strut to final drive	51 ± 6
Bearing mount to gearbox	41 ± 5
Bottom section of air cleaner housing to engine block	21 ± 1
Frame to engine, intermediate flange, gearbox	45 – 6
Starter motor to gearbox	7 ± 1
Radiator to frame	8.5 ± 1
Silencer to exhaust pipe	20.5 ± 2
Silencer to footrest plate	9 ± 1

Engine: general layout

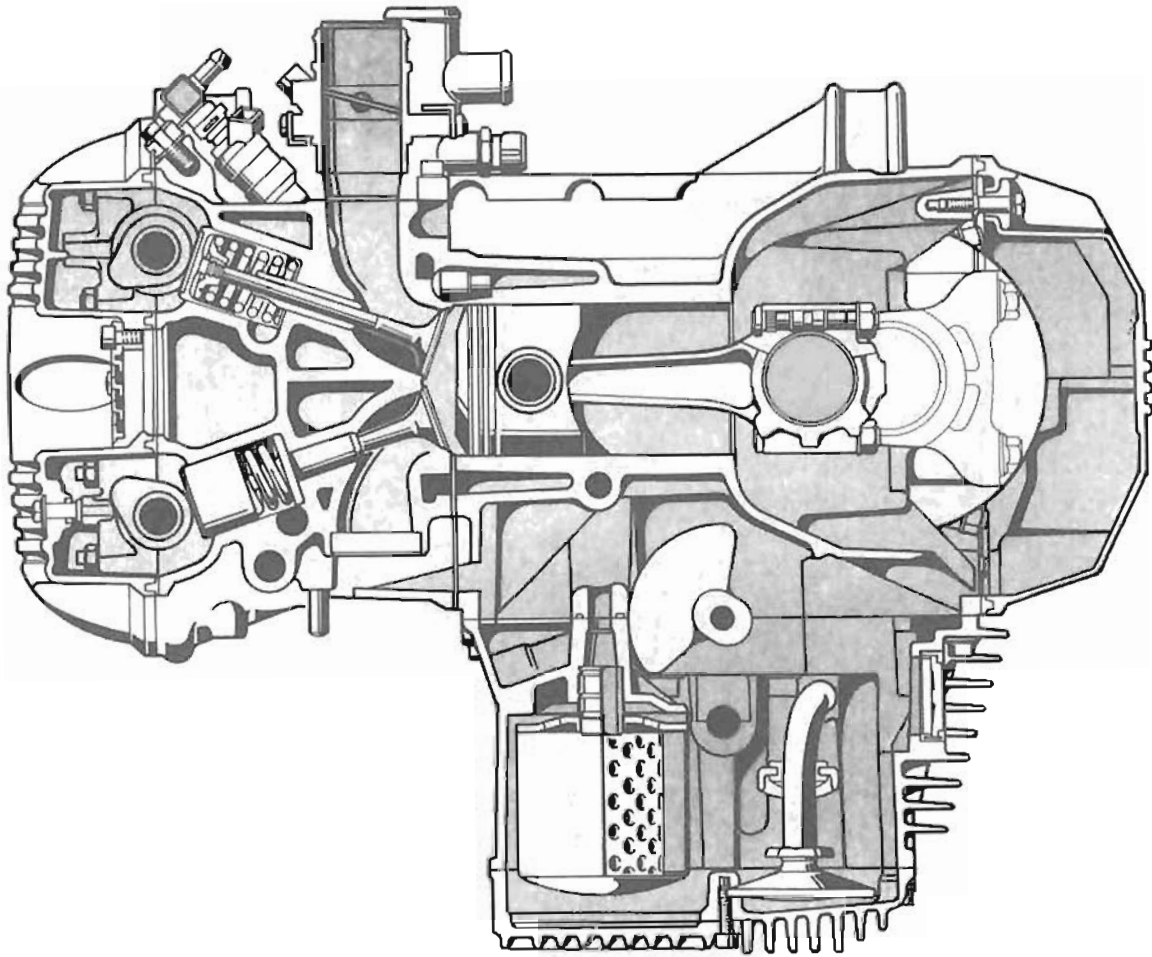

Engine: valve gear

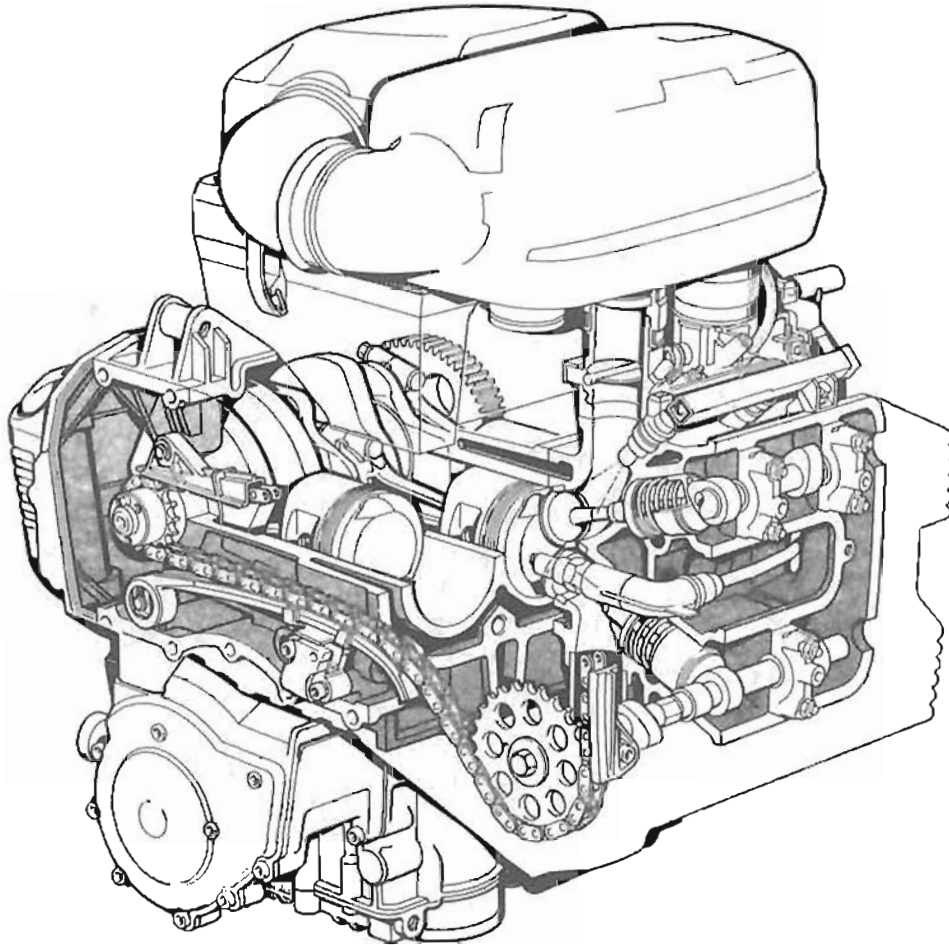

Engine: oil circuit

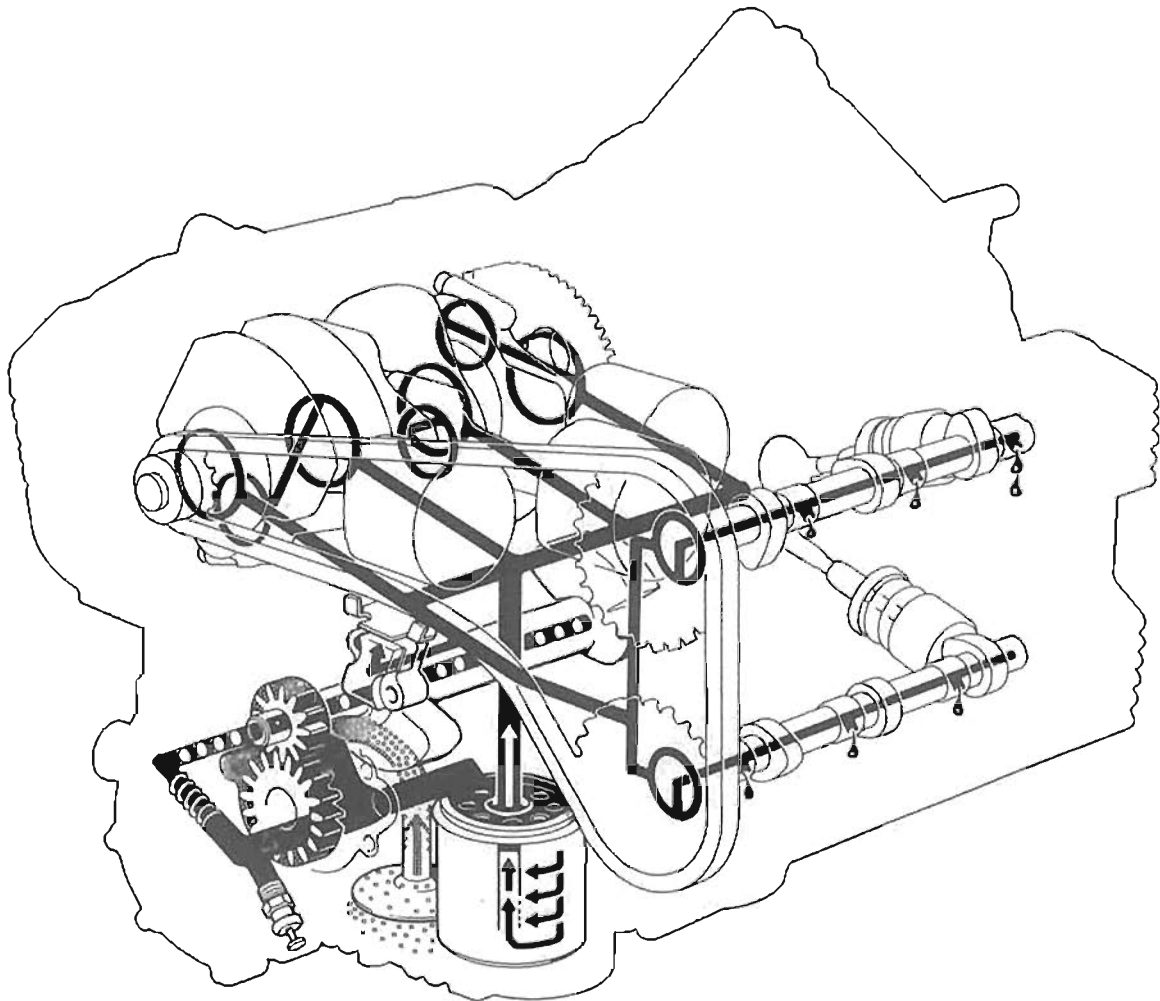

Engine: shaft arrangement

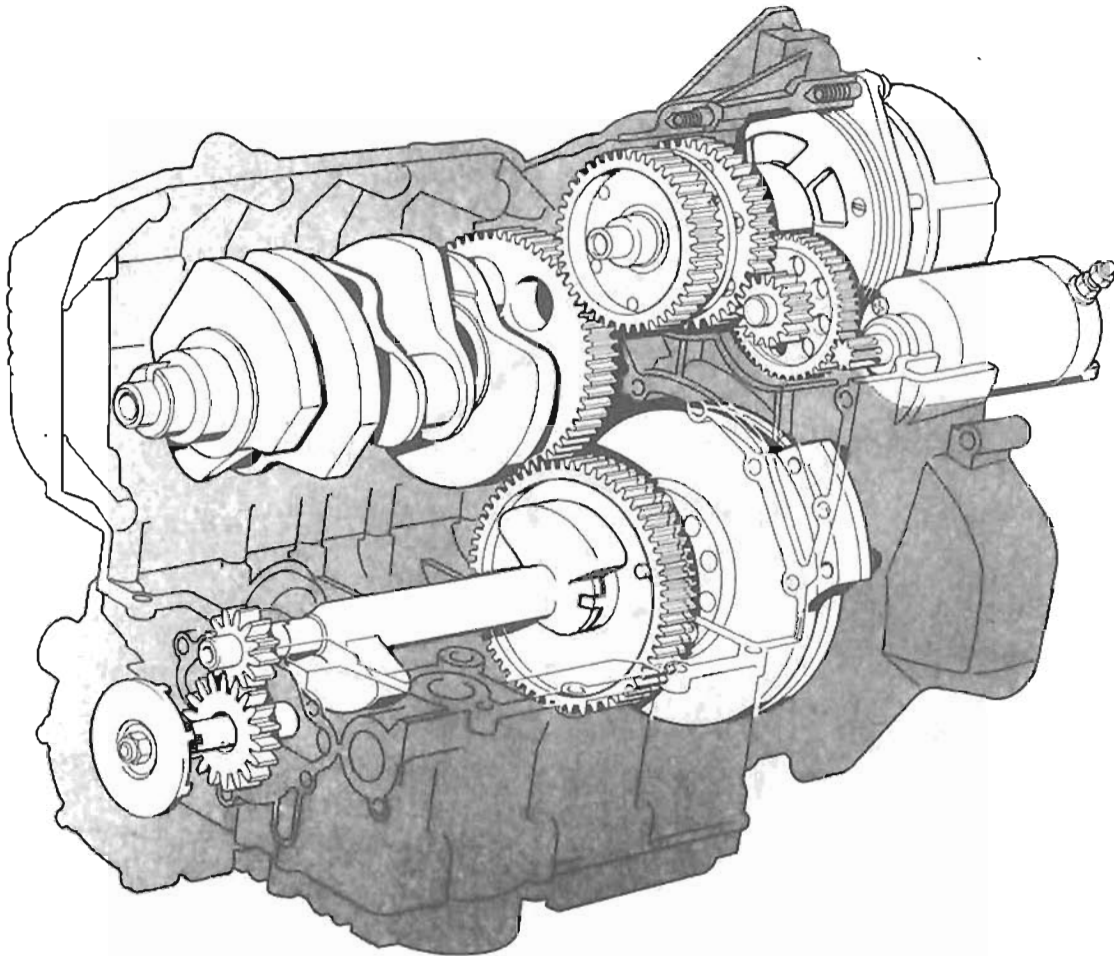

Engine: shaft arrangement

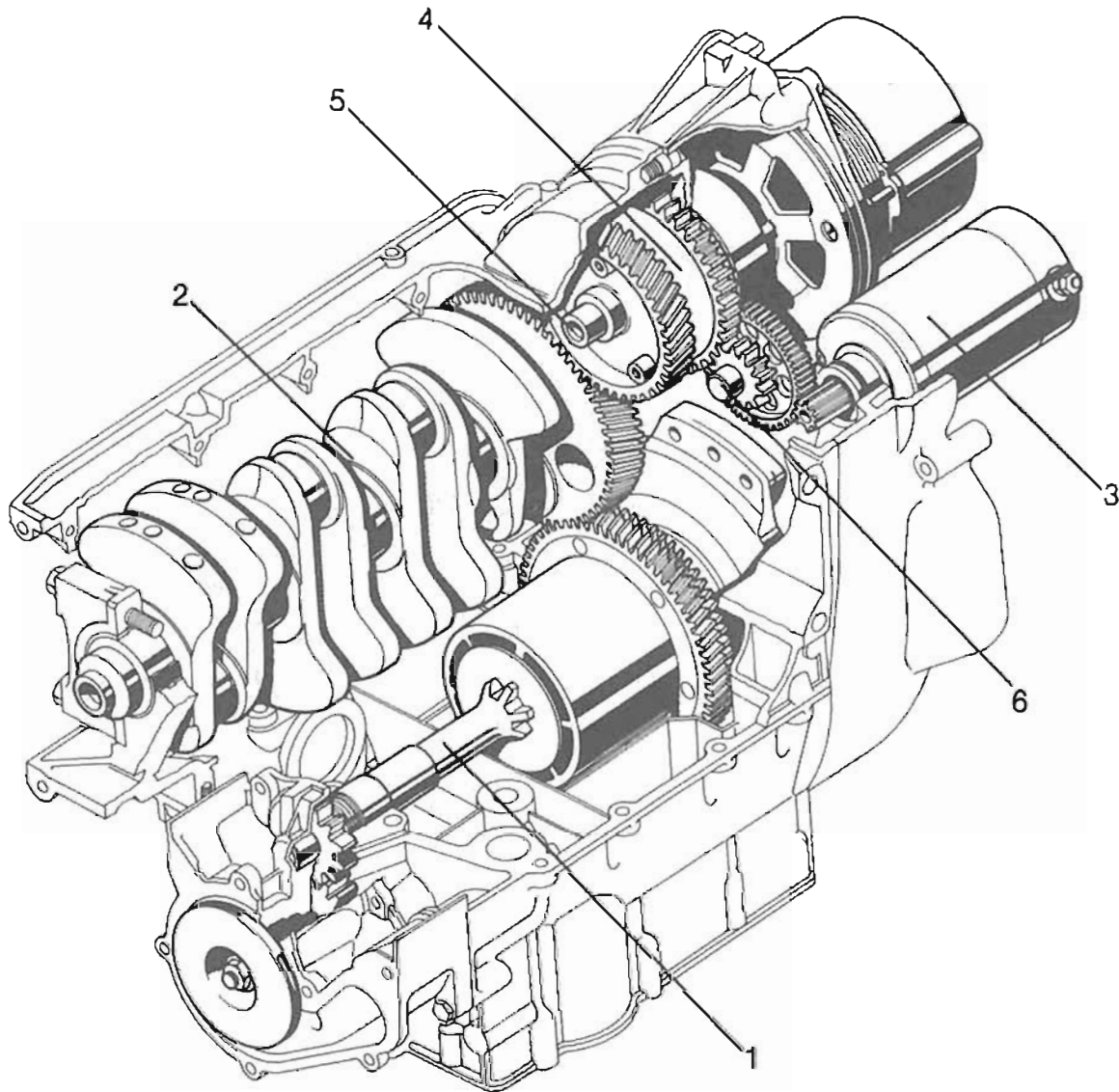

- 1 Output shaft
- 2 Crankshaft
- 3 Starter

- 4 Freewheel
- 5 Auxiliary shaft
- 6 Countershaft

Crankshaft with connecting rod and piston

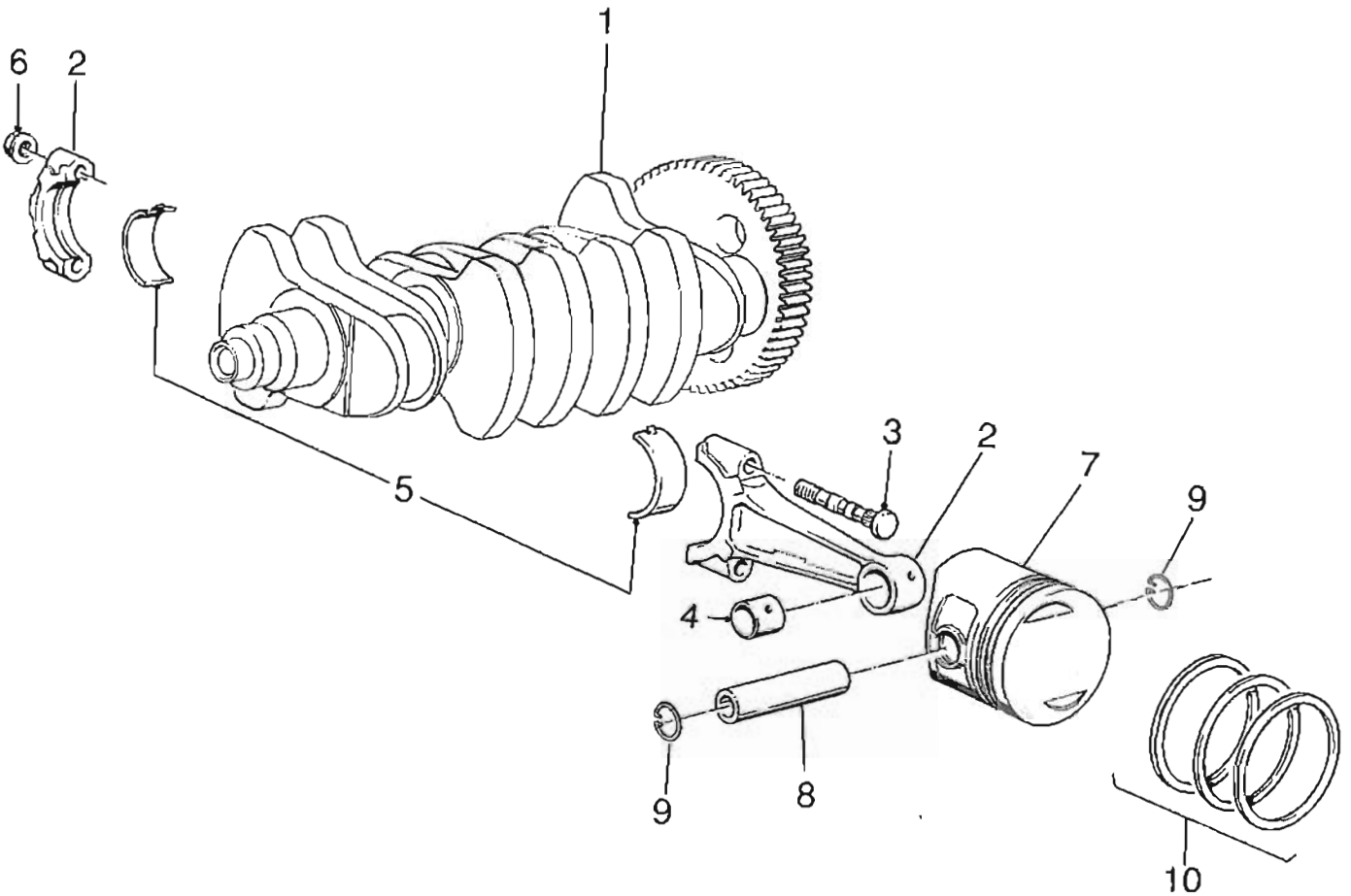

- 1 Crankshaft
- 2 Connecting rod
- 3 Big end bolt
- 4 Small end bearing
- 5 Big end bearing shell

- 6 Nut
- 7 Piston
- 8 Piston bolt
- 9 Circlip
- 10 Piston rings

Output shaft

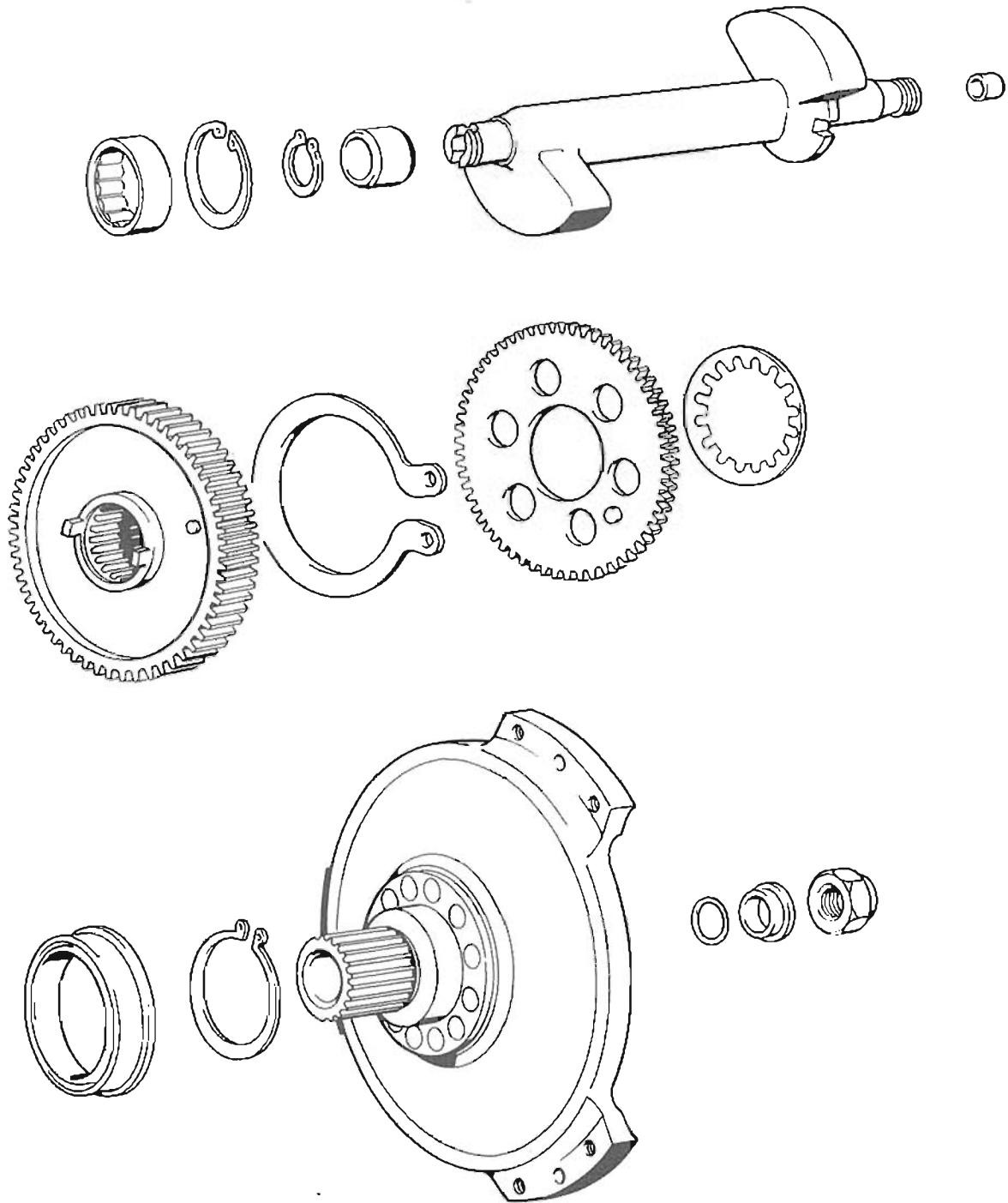

Output shaft

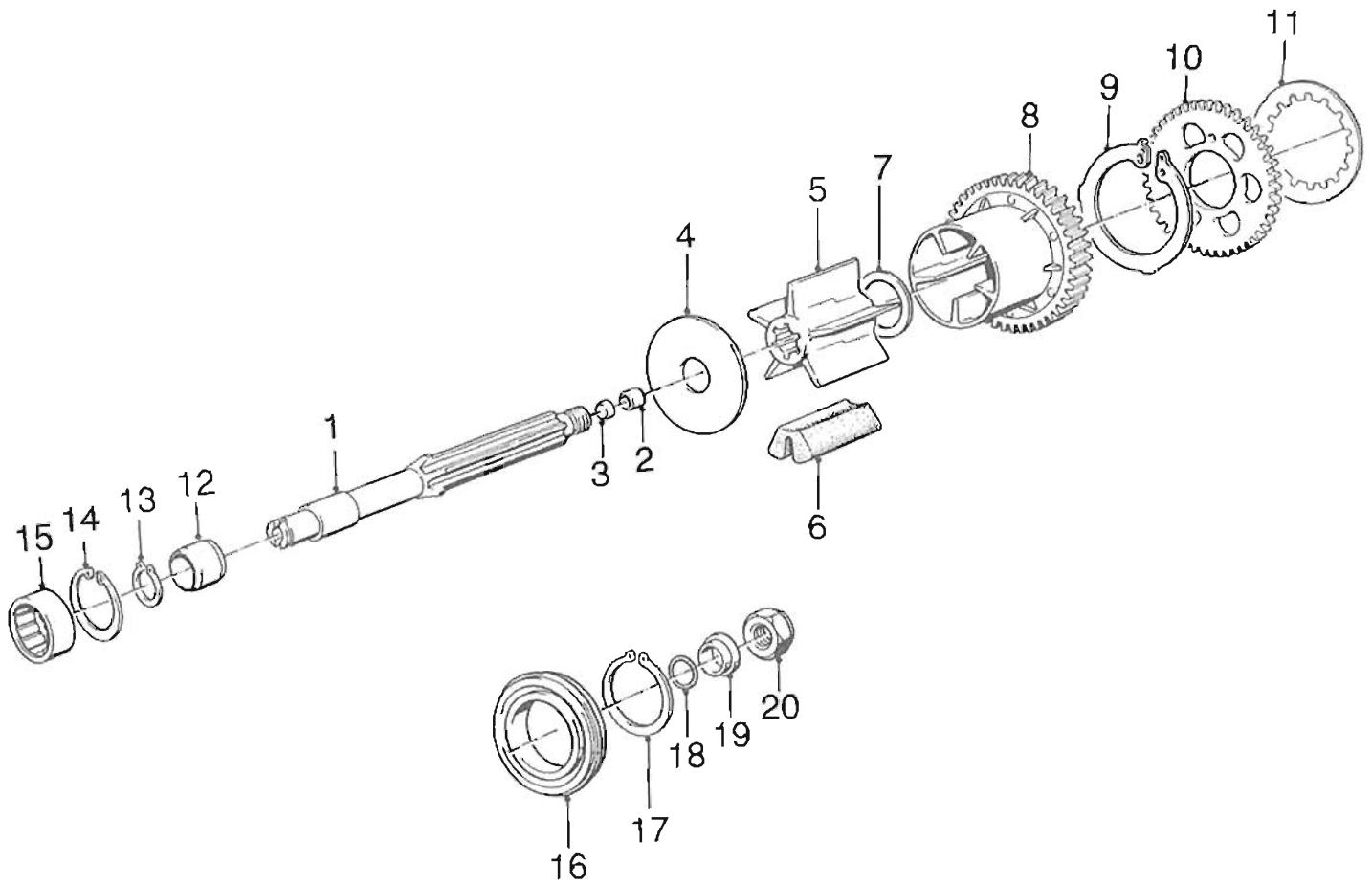

- | | |
|-----------------------|-----------------------------|
| 1 Output shaft | 11 Cup spring |
| 2 Bushing | 12 Bearing inner ring |
| 3 Stop cover | 13 Snap ring |
| 4 Retaining plate | 14 Snap ring |
| 5 Damper | 15 Needle roller race |
| 6 Rubber damper block | 16 Deep-groove ball bearing |
| 7 Stop plate | 17 Snap ring |
| 8 Damper housing | 18 O-ring |
| 9 Spring | 19 Thrust piece |
| 10 Tensioning gear | 20 Hex nut |

Intermediate flange

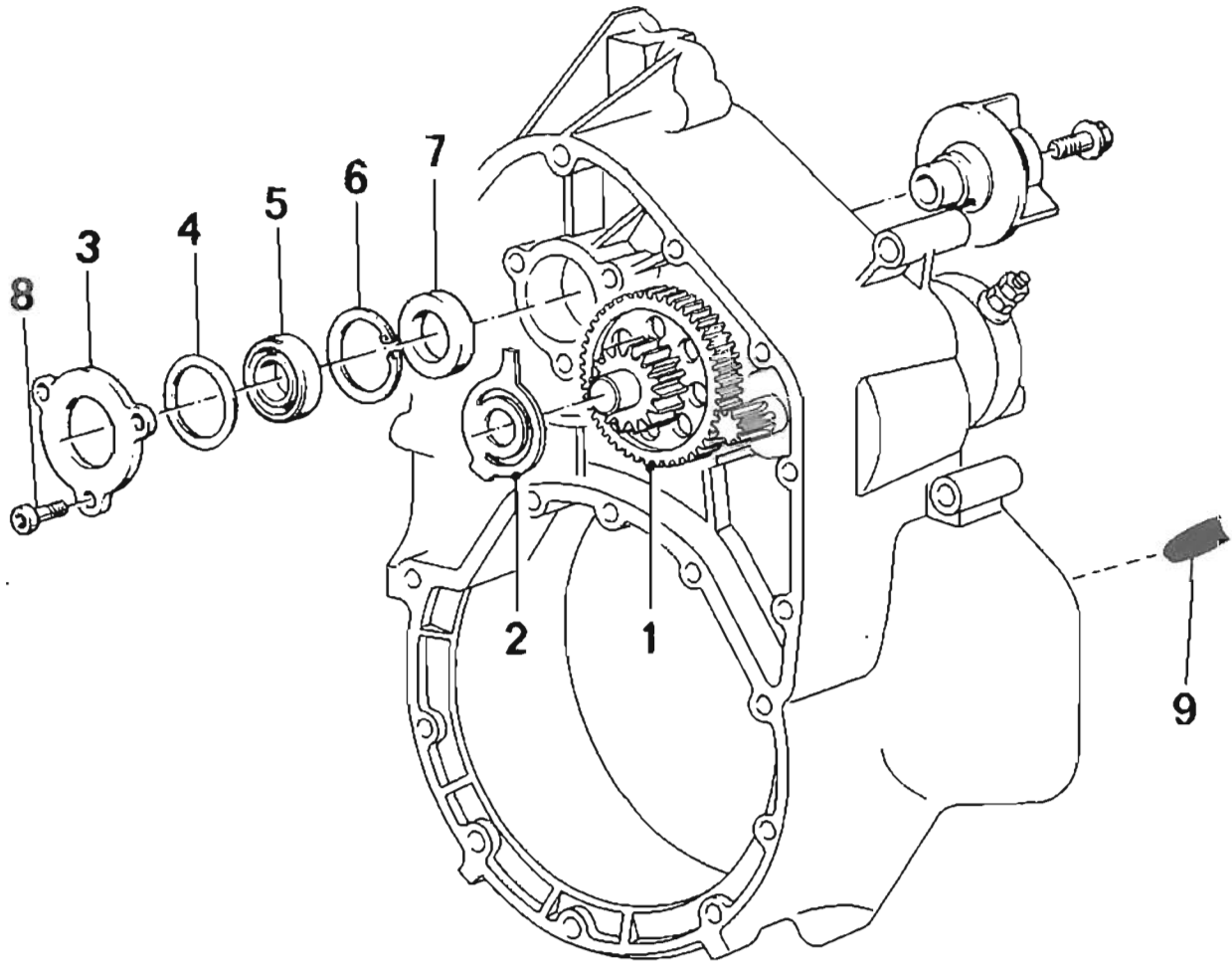

- 1 Countershaft
- 2 Spring
- 3 Stop plate
- 4 Cup spring
- 5 Ball bearing
- 6 Circlip
- 7 Shaft sealing ring
- 8 Retaining bolt

Auxiliary shaft with freewheel

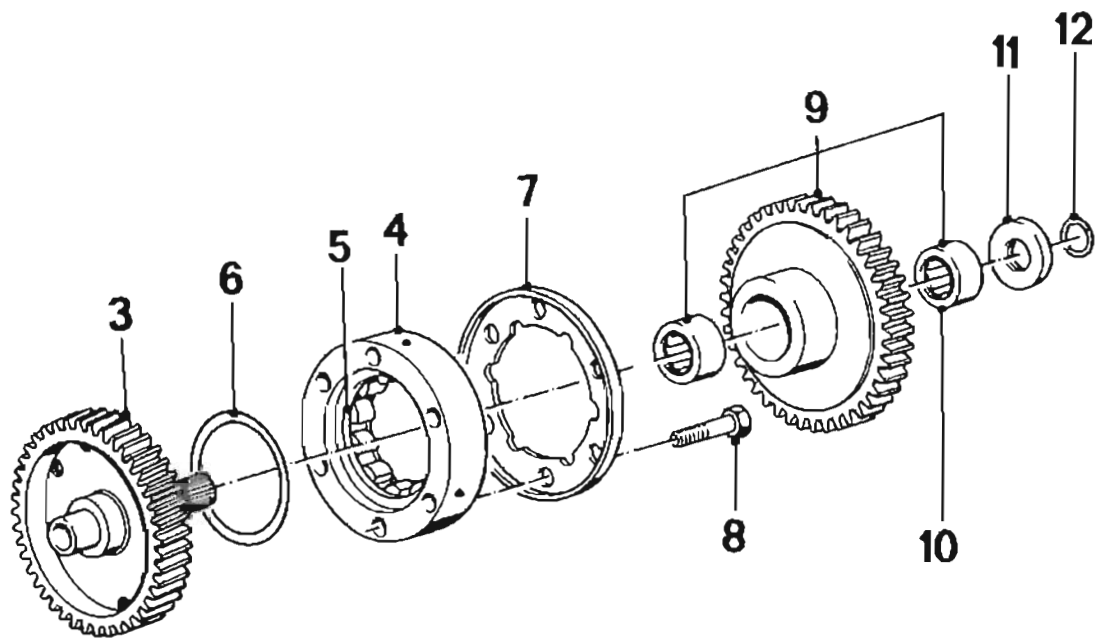

- 3 Auxiliary shaft
- 4 Freewheel cage
- 5 Freewheel outer ring
- 6 Cup spring
- 7 Cover plate

- 8 Retaining bolt
- 9 Freewheel gear
- 10 Needle roller bearing
- 11 Washer
- 12 O-ring

Combined water and oil pump

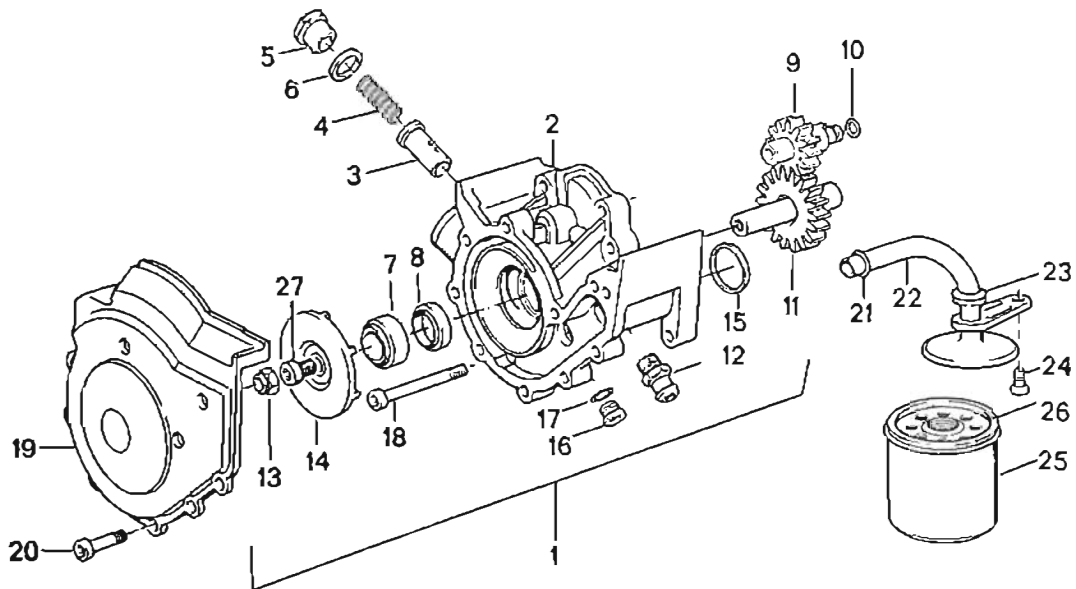

- | | |
|------------------------|-------------------|
| 2 Pump housing | 15 O-ring |
| 3 Piston | 16 Drain screw |
| 4 Coil spring | 17 Sealing ring |
| 5 Screw plug | 18 Retaining bolt |
| 6 Sealing ring | 19 Cover |
| 7 Axial face seal | 20 Retaining bolt |
| 8 Shaft sealing ring | 21 O-ring |
| 9 Output shaft | 22 Pipe |
| 10 O-ring | 23 Bushing |
| 11 Shaft | 24 Retaining bolt |
| 12 Oil pressure switch | 25 Oil filter |
| 13 Nut | 26 O-ring |
| 14 Water pump impeller | 27 Retaining bolt |

Engine – removing

Remove fairing (see page 46–17.0)

Remove fuel tank (see page 16–07.0)

Pull off fuel injection control unit cover in the direction of the arrow.

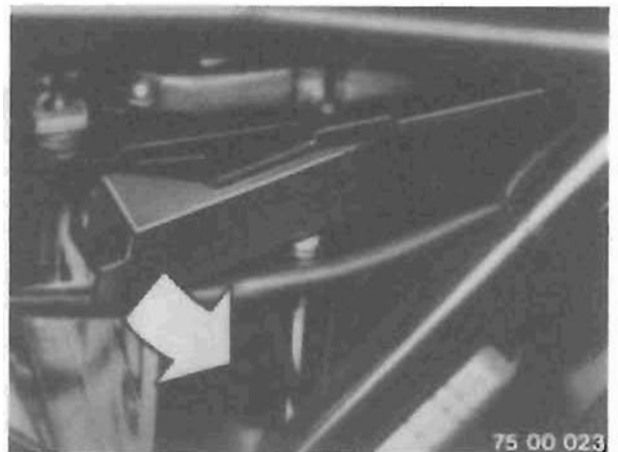

Push back the retaining plate for the multi-pin plug in the direction of the arrow.
Pull off the multi-pin plug to the rear and then disengage it at the front.

Take out the storage tray with fuel injection control unit to the rear and top.

Note:

Note the rubber plug.

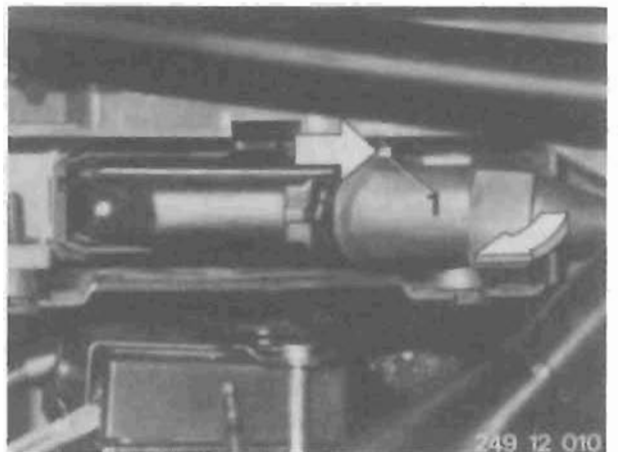

Battery – removing

Remove the battery holder retaining screws (arrows).

Unscrew the negative lead at the gearbox, then the positive lead at the battery post.

Pull off the bleed hose at the battery and take out the battery.

(Rotate the 30 Ah battery through 90°.)



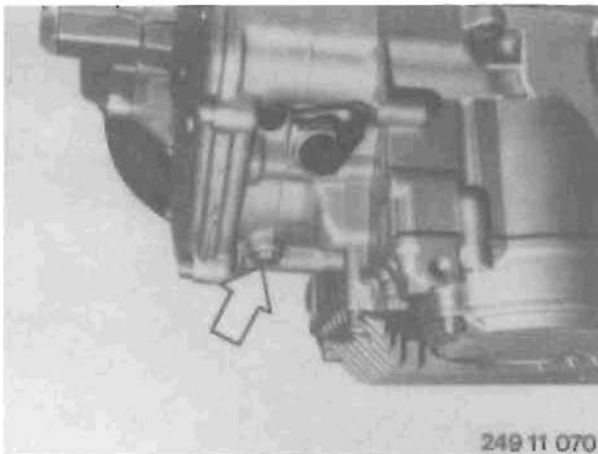

Coolant – draining

Slacken off the drain screw (arrow) and drain the coolant.

Note:

Loosen the filler pipe cover to drain the system more quickly.

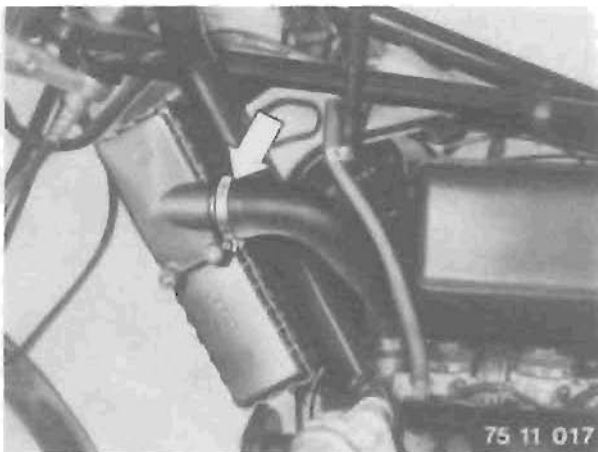

Radiator – removing

Release the hose clip (arrow) on the left of the radiator and pull off the hose.

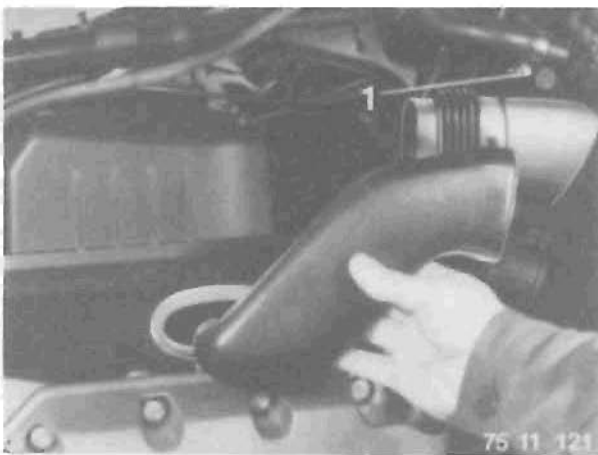

Release the hose clip (1) at the top right of the radiator and pull off the hose.

Pull out the intake air line on the lower section of the air cleaner housing and pull off at the intake pipe.

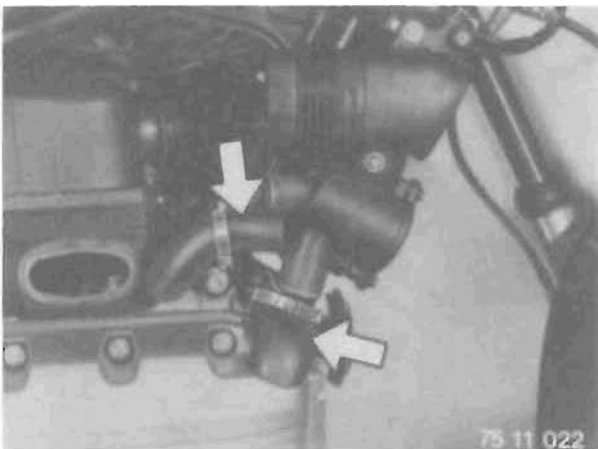

Release the hose clips (arrows) on the left of the thermostat housing and pull off the hoses.

Unscrew the radiator retaining bolt (arrow) at the frame. Tilt the radiator to the front at the top, separate the plug connection at the fan motor and take off the radiator to the front.

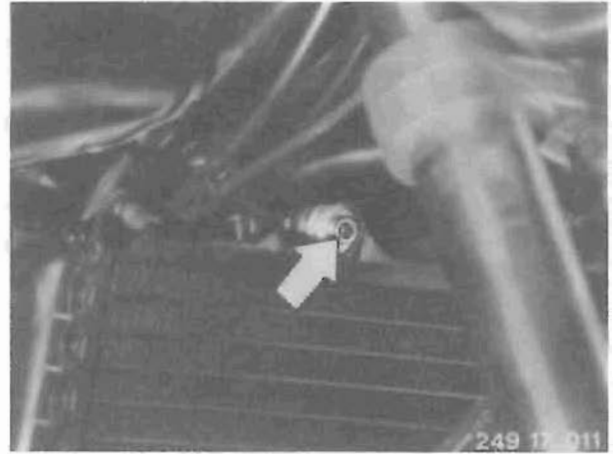

Throttle cable on throttle butterfly stub pipe assembly – detaching

Turn the sector inwards in the direction of the arrow and disconnect the nipple. Detach the throttle cable from the reaction bearing.

Warning:

Do not bend the throttle cable.

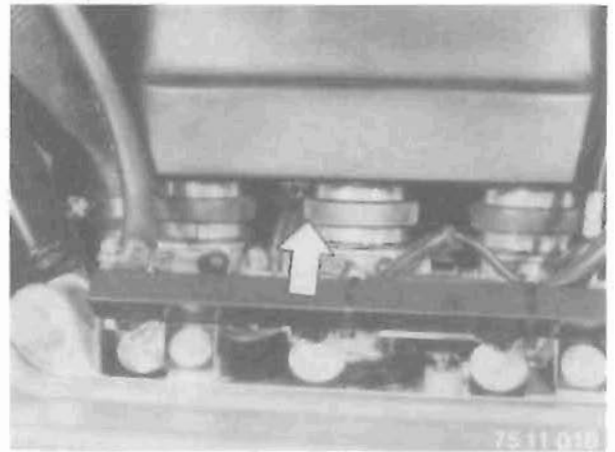

Clutch cable – detaching

Disconnect the choke cable at the operating lever (arrow) and pull it out through the opening in the gearbox housing.



Cable for increased starting speed – detaching

Take off the cover on the increased starting speed lever. Unscrew the retaining bolt, remove the lever and detach the cable.

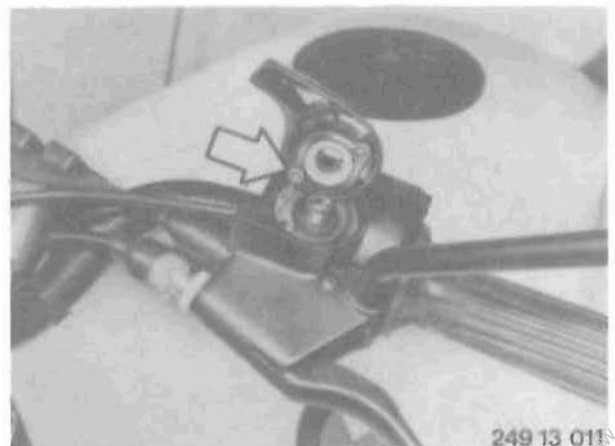

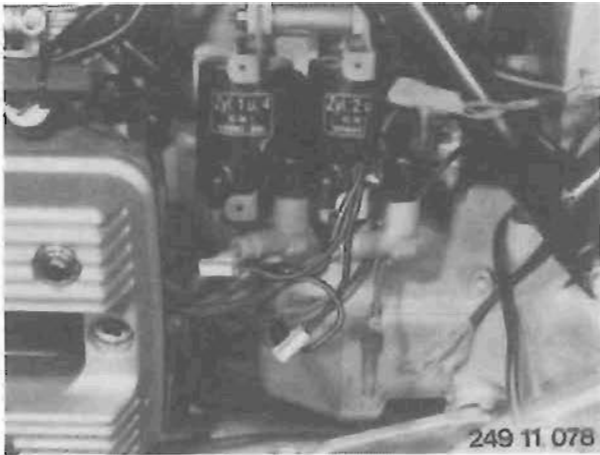

Ignition cables – removing



Remove the ignition coil cover, pull off cables at terminals 1 and 15 and pull off spark plug cap.

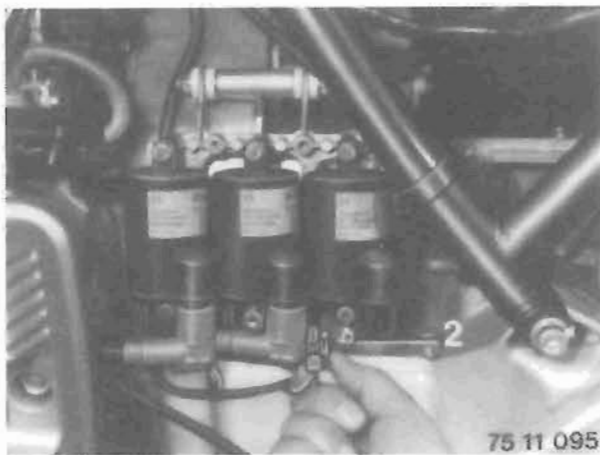

Remove ignition coil cover and pull off double plug on ignition coils.
Pull off earth (2) on the third ignition coil.
Pull off spark plug cap.

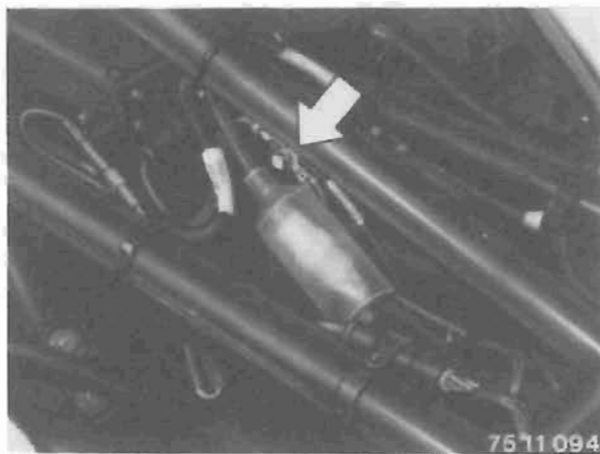

Pull off cap (arrow) on alternator.
Detach cable (1) on starter.
Disconnect cable connector (3) on frame.



Plug connections – uncoupling

Detach the cable connector at the frame and separate the following plug connections: engine wiring harness, switch for increased starting speed.

Detach the earth connection (arrow) from the frame.

Separate the plug connection for the Hall-effect transmitter (1) and oil pressure switch (2) from the frame wiring harness.

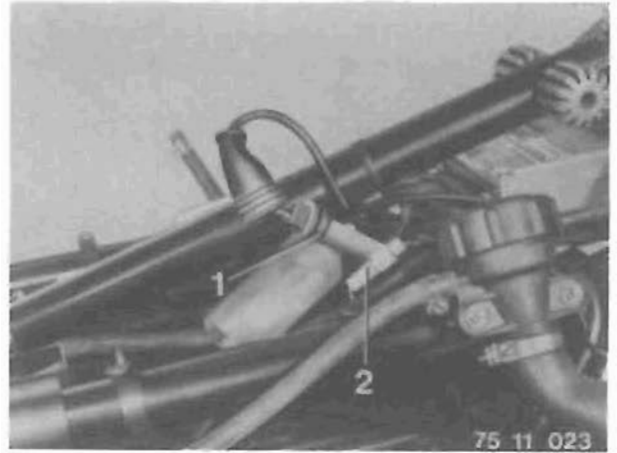

Separate the plug connections (arrows) for the gearbox switch, brake light switch and inductive sensor. Separate cable connector (2).

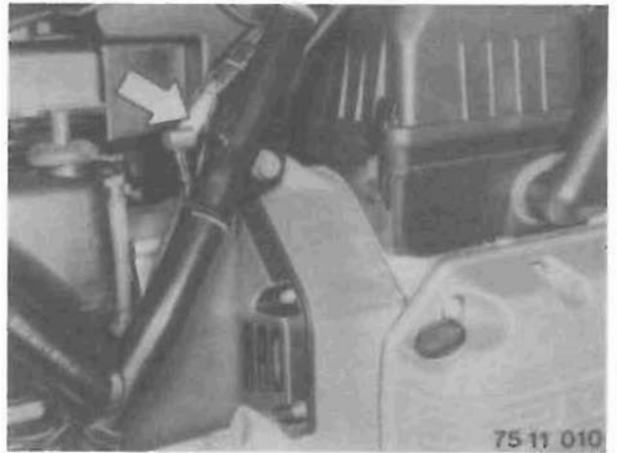

Exhaust system – removing

Slacken off the nuts (arrows) for securing the exhaust pipes to the cylinder head.

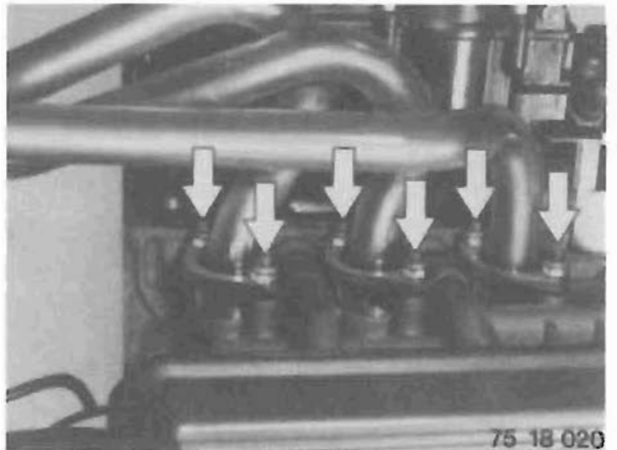

Loosen the silencer mounting at the footrest plate and remove the complete exhaust system.

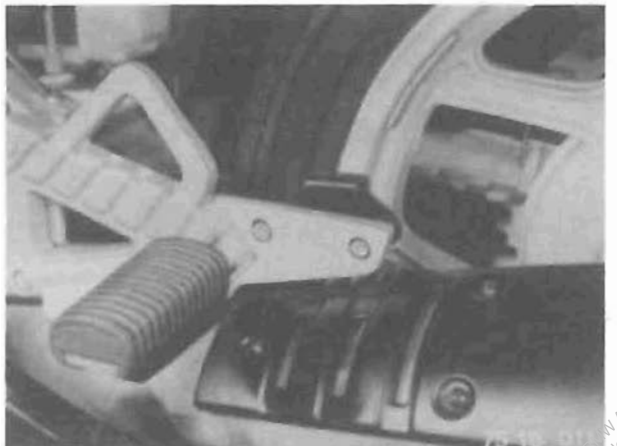

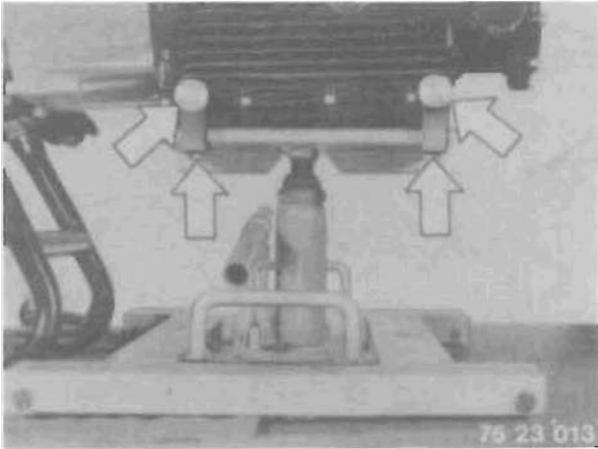

Attach BMW hoist 00 1 510 to the oil sump.
Tighten the retaining screws (arrows).
Raise the engine so that there is no load on the centre stand.

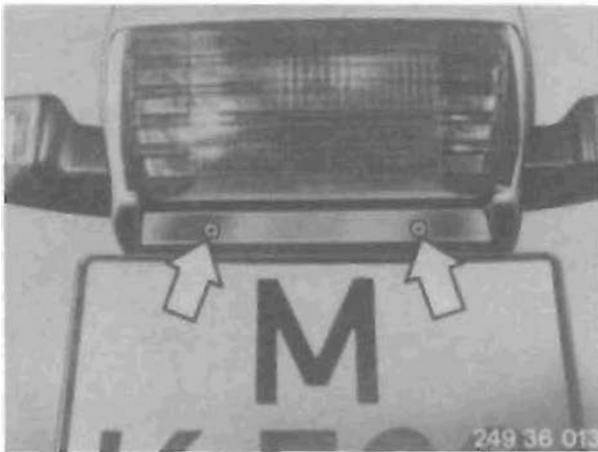

Remove the retaining screws (arrows).
Remove the nuts in the storage compartment and take off the licence plate holder.

Note:
Note the protective caps.



Release the retaining screws (arrows) and take off the rear mudguard.



Secure the coolant reservoir to the frame with wire.

Unscrew the frame retaining bolts at the left and right of the gearbox.

Slacken off the bolts (arrows) and take off the alternator cover.

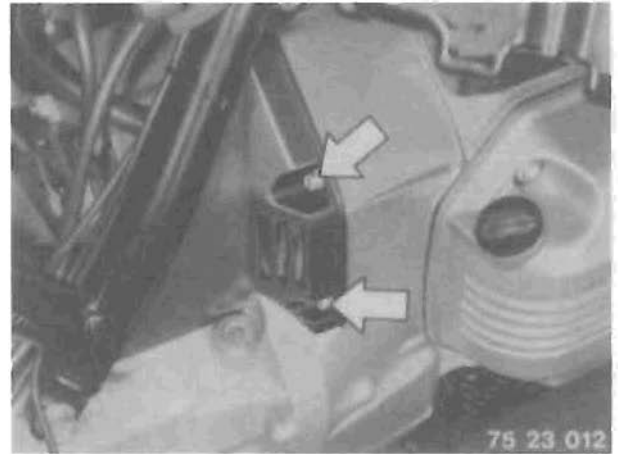

Driveline – removing

Slacken off the retaining bolts (arrows) for the bearing mount on the underside of the gearbox. Take off the bearing mount with the centre and side stands.

Note:

The screws are microencapsulated (self-locking) and cannot be reused.

Slacken off the bolts securing the gearbox to the engine behind the bearing mount and secure bearing mount to the gearbox again.

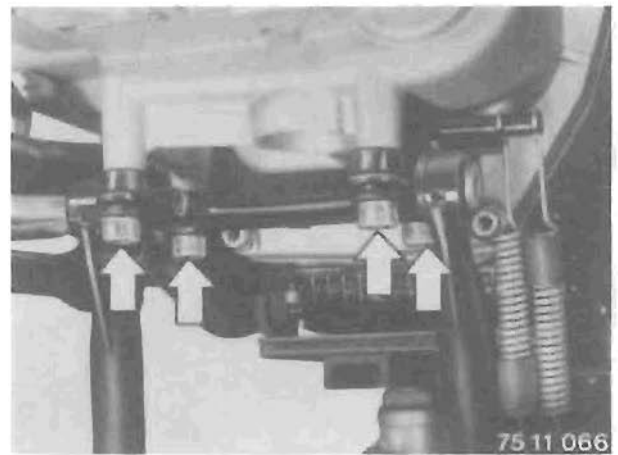

Slacken off the starter motor retaining bolts at the gearbox. Slacken off the gearbox retaining bolts (arrows) at the engine.

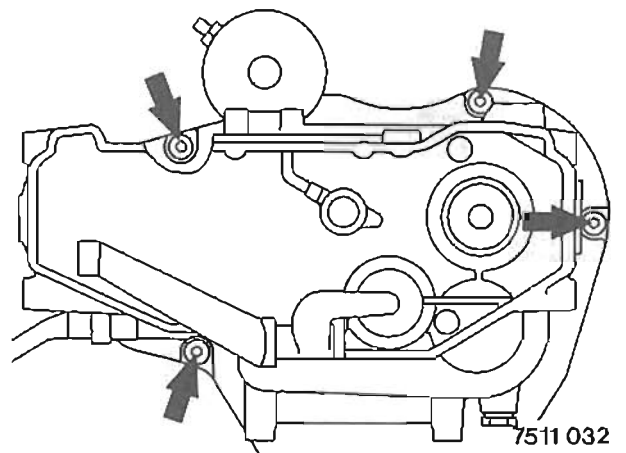

Detach the spring strut at the bottom and pull the bottom spring strut eye out in the direction of the arrow over the threaded pin.

Note:

To avoid damaging the driveshaft flexible gaiter, tie up the swinging arm with wire or similar or wedge a piece of wood between the swinging arm and the gearbox housing.



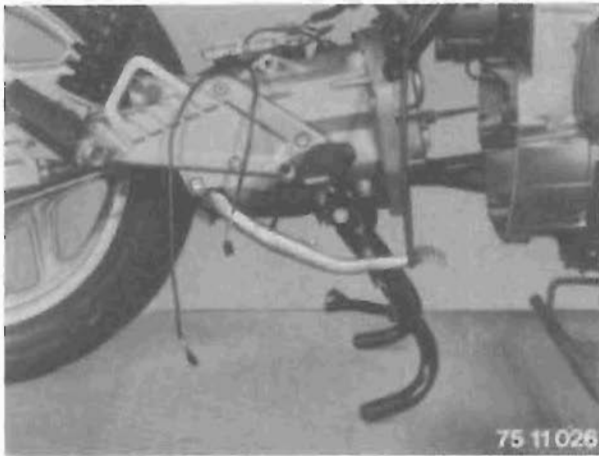

Lower the lifting fixture so that the centre stand stands upright.

Note:

The engine and gearbox must be at the same height to avoid damaging the clutch release rod.

Pull the gearbox with complete driveline away to the rear.

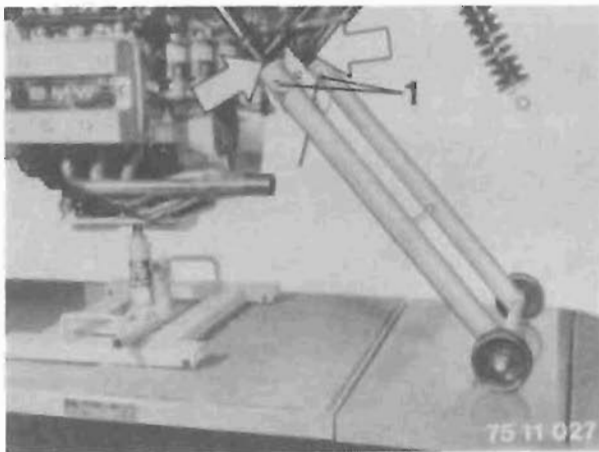

Push BMW frame support 46 5 620 on to the rear frame tubes (arrows) and secure it with pin (1).

Detach the remaining frame mountings at the front left and right of the engine and also at the right of the intermediate flange.

Note:

Note the shims.



Lift off the frame complete with telescopic fork and place it on the workshop floor.

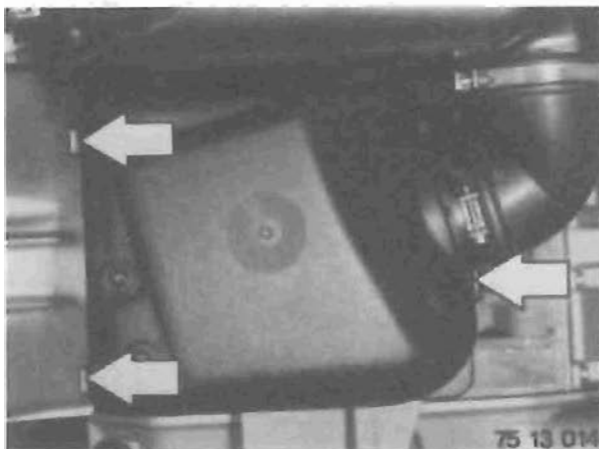

Detach the hose clip (1) at the air collector.

Open the retaining clips (arrows) for the air cleaner housing and separate the following plug connections: temperature sensor, injector nozzles and throttle butterfly switch.

Separate the cable connector at the injector rail and take off the top section of the air cleaner housing with the engine wiring harness.

Take off the air cleaner insert.
Slacken off the retaining screws (arrows) for the bottom section of the air cleaner housing.
Take off the bottom section of the air cleaner housing.



Attach BMW engine lifting fixture 11 0 610 to the crankcase (arrows).

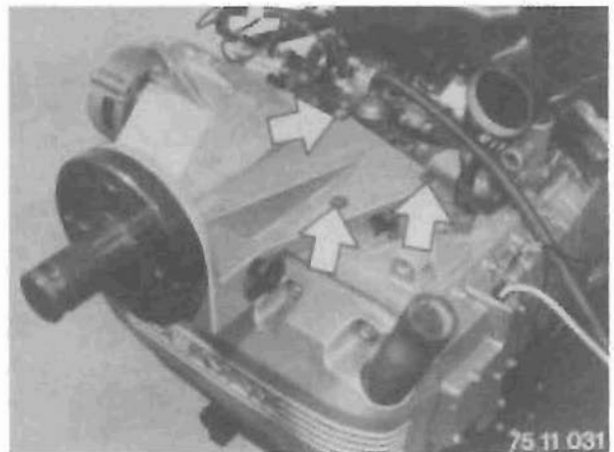

Lower the lifting fixture until the engine mount can be joined to the assembly stand.
Detach the lifting fixture from the engine (arrows).

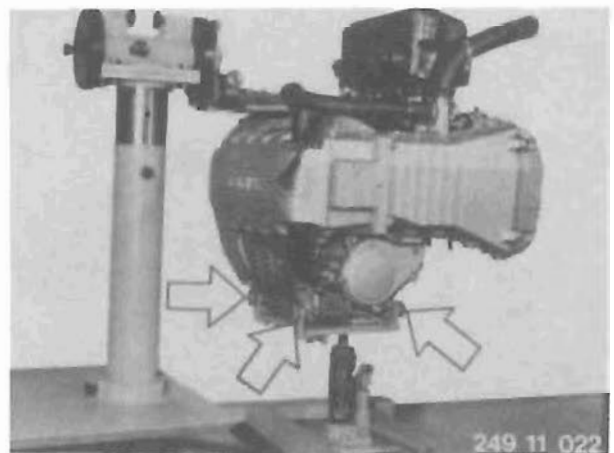

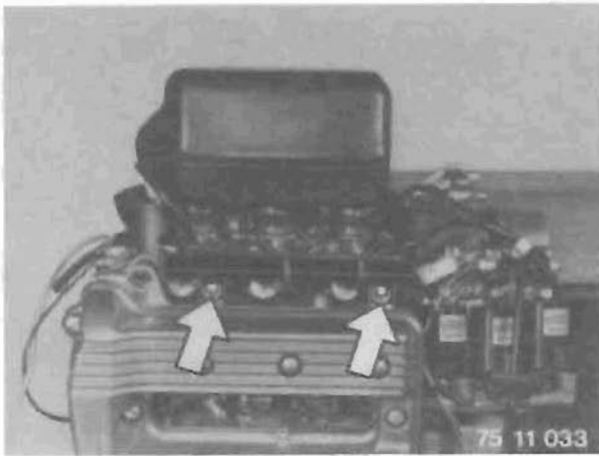

Engine – stripping down

Injector rail – removing

Drain off engine oil.

Slacken off the injector rail retaining screws (arrows). Pull out the injector rail complete with injectors from the cylinder head and set it down on the crankcase.

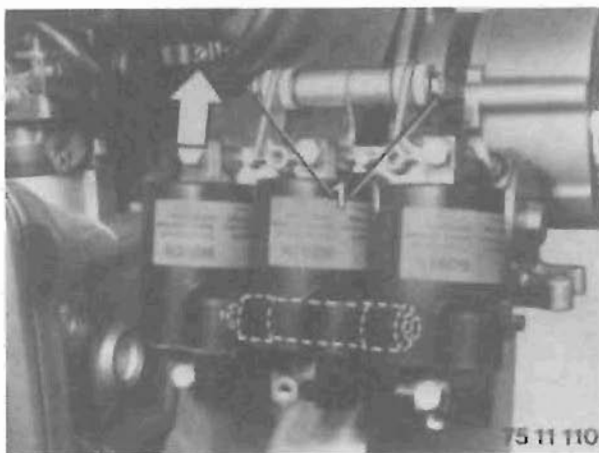

Ignition coils – removing

Loosen the hose clip (arrow) for the crankcase breather.

Pull the plugs off the ignition coils.

Slacken off and pull out retaining screw (1) (the ignition coils fold forwards). Slacken off the retaining screws at the bottom and take off the ignition coil holder with ignition coils.

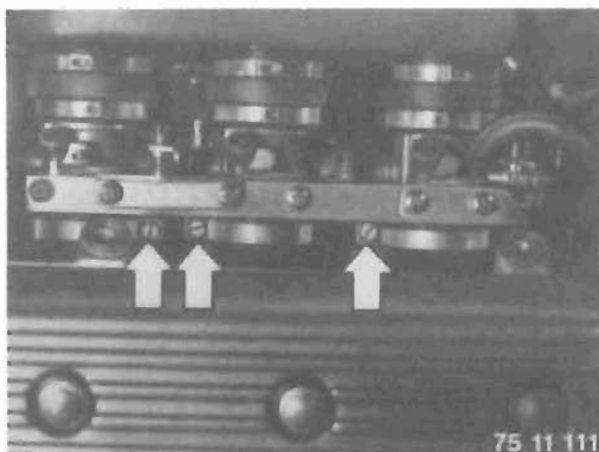

Butterfly valve stub pipe assembly with air collector - removing

Release the hose connector at the air intake stub and take off the throttle butterfly stub pipe assembly complete with air collector and injector rail.

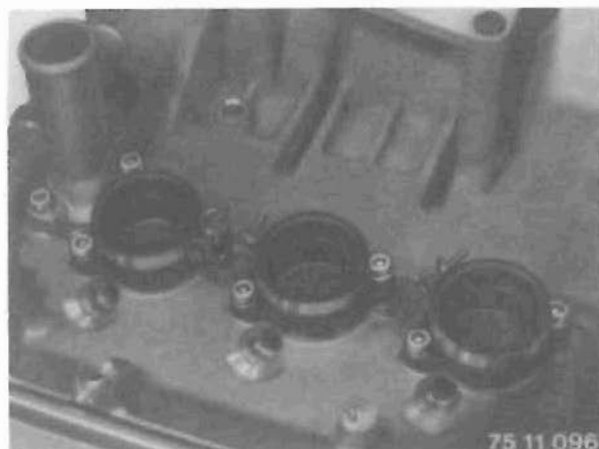

Intake pipe/coolant pipe – removing

Slacken off the retaining screws for the intake and coolant stubs and remove these items.

Turn the engine round (clutch side at top).

Alternator and starter – removing

Remove the alternator retaining screws (arrows) and take off the alternator.

Pull the starter motor (1) out of the intermediate flange.

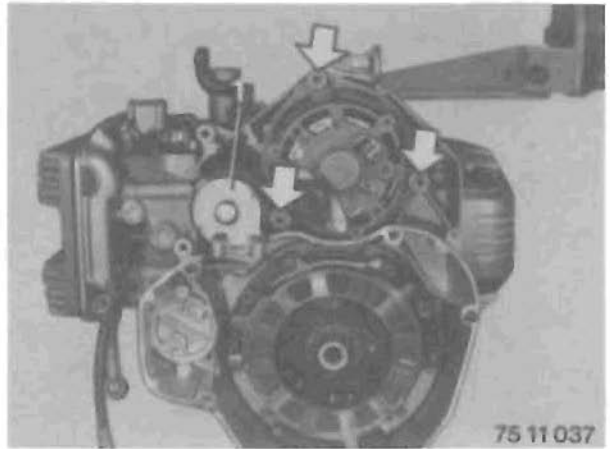

Driver – removing

Slacken off the driver retaining screw (1) and pull off driver with BMW puller 00 8 400.

Note:

Note O-ring.

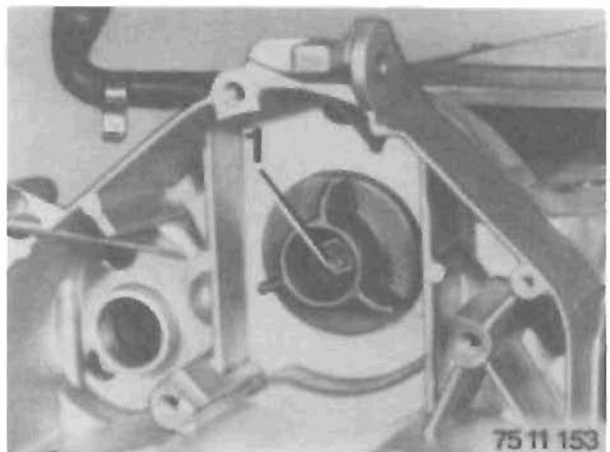

Clutch – removing

Slacken off the retaining screws (arrows) for the housing cover and take it off with the clutch plate and pressure plate.

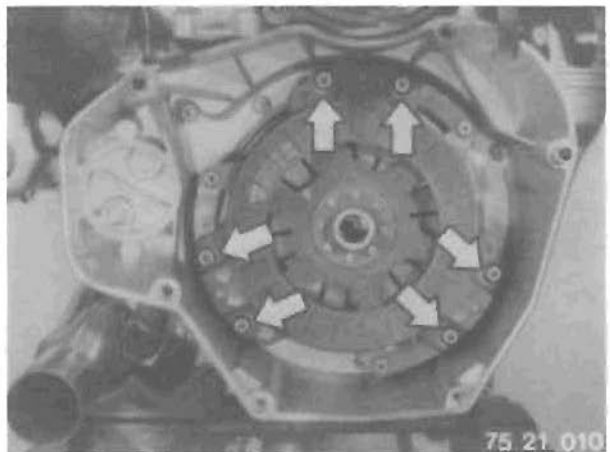

Clutch housing – removing

Attach BMW retainer 11 2 800 in the position shown in the picture.

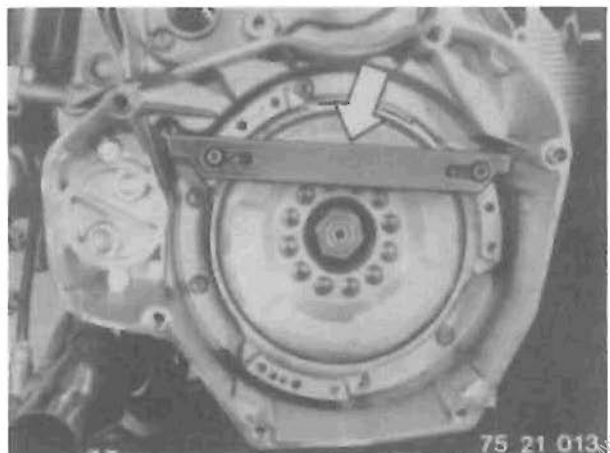

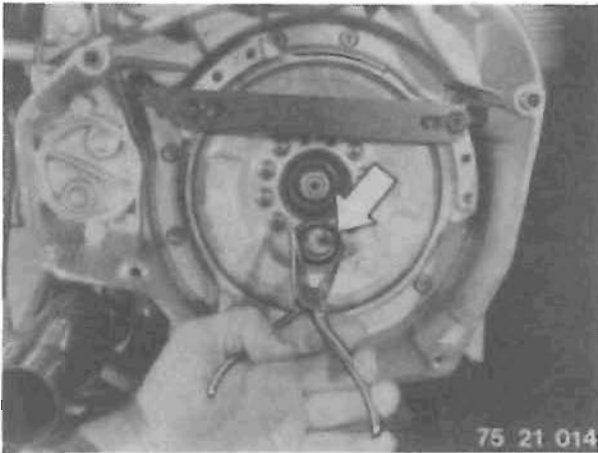

Unscrew and remove the hex nut.
 Take out the thrust washer (arrow).
 Move the clutch housing to and fro until the O-ring is visible. Cut through the O-ring with a knife and take it out.
 Pull off the clutch housing.



Note the stop plate between clutch housing and output shaft.

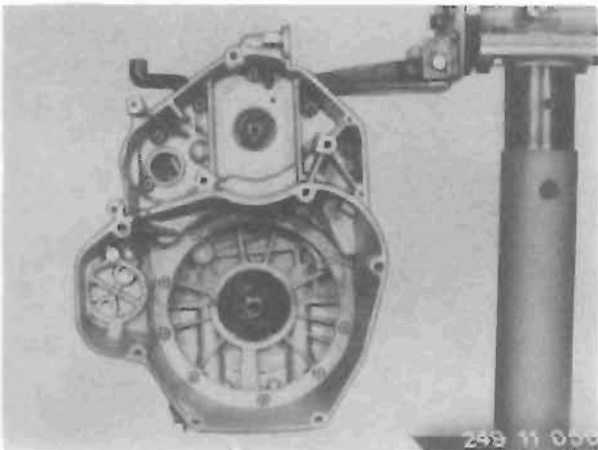

Intermediate flange – removing

Slacken off the screws holding the intermediate flange with BMW Torx insert 00 2 600, and pull off the intermediate flange.

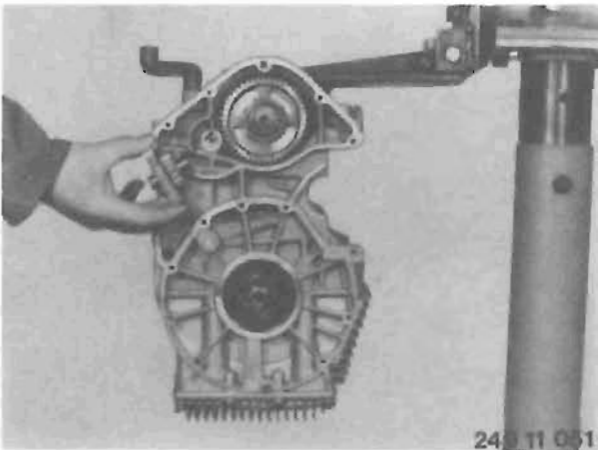

Countershaft – removing

Pull the countershaft out of the crankcase.

Note:
 Note the spring.

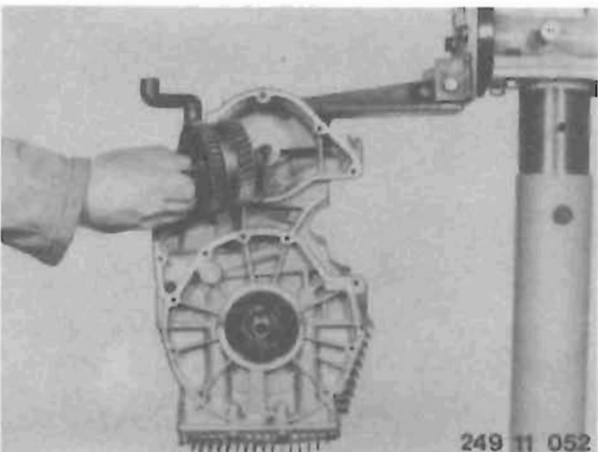

Auxiliary shaft – removing

Pull the auxiliary shaft with freewheel out of the crankcase.
 Turn the engine round (oil sump at top).

Lid for water pump – removing

Slacken off the water pump cover retaining screws (arrows) and take off the cover.

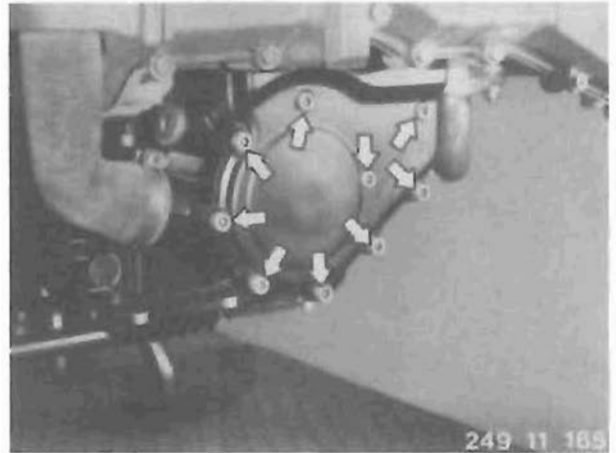

Combined water/oil pump – removing

Release the hose clip at the water pump and pull the water hose off the pump housing. Disconnect the oil pressure line and insert it in the hole in the pump housing. Slacken off the pump housing retaining screws (arrows) and pull off the pump.

Note:

Note the O-ring (water passage).

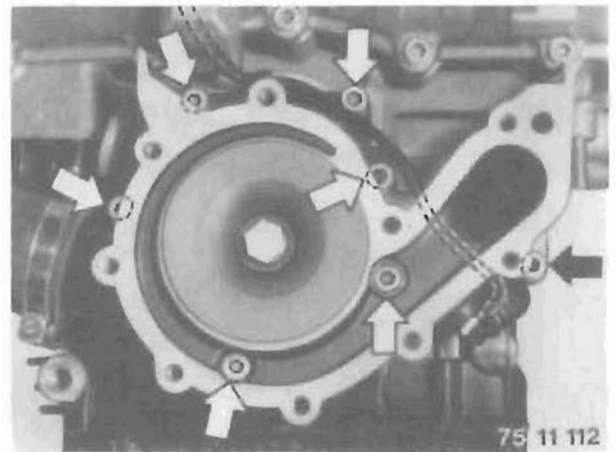

Oil sump – removing

Remove the screws holding the oil sump (arrows) and take off the oil sump.

(To provide a better illustration here, the engine has been turned through 90°.)

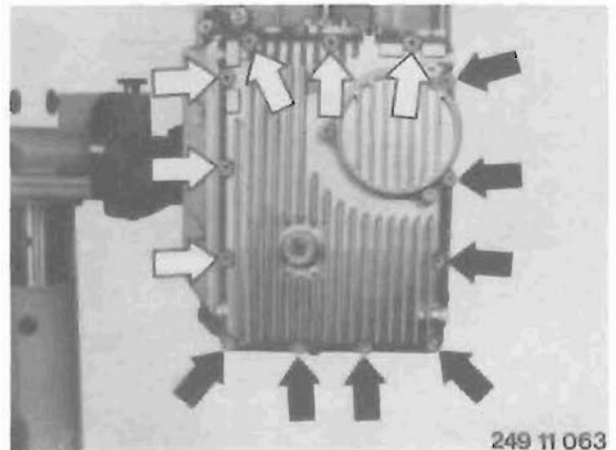

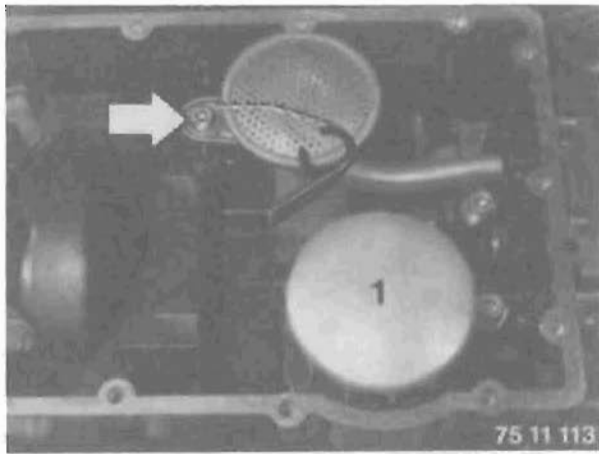

Oil mesh strainer and oil filter cartridge – removing
 Slacken off the oil filter retaining bolt (arrow) and pull the pipe with O-ring out of the rubber bushing in the the lower section of the crankcase.
 Unscrew and remove the oil filter cartridge (1) using BMW oil filter wrench 11 4 650.

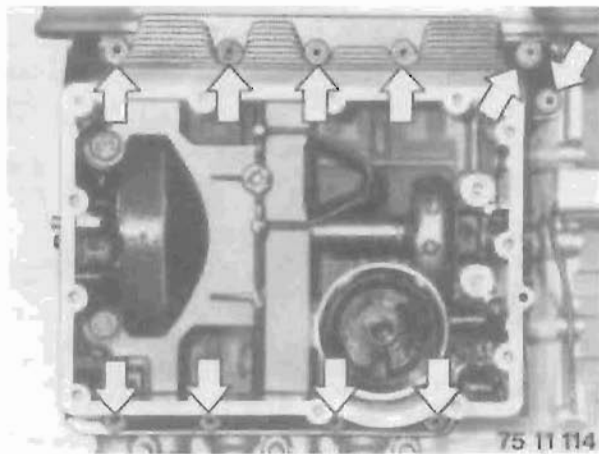

Crankcase lower section – removing
 Remove the bolts (arrows) retaining the lower section of the crankcase.

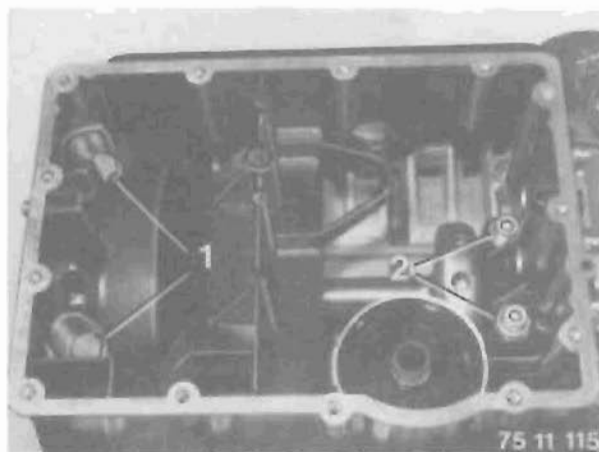

Slacken off retaining bolts (1 and 2).
 Take off the bottom section of the crankcase.

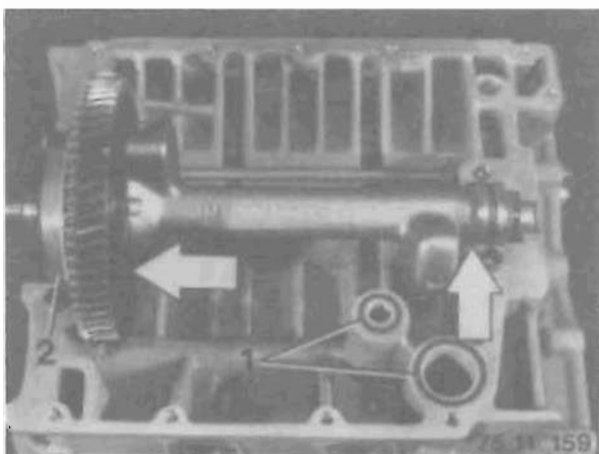

Output shaft – removing
 Take the output shaft out of the crankcase.
Note:
 The gearwheel and needle roller bearing (arrow) are loose on the output shaft.
 Take out the O-rings (1) for the water and oil passages.
 Take off shaft sealing ring (2).

Rocker cover – removing

Slacken off the rocker cover retaining screws and take off the rocker cover.

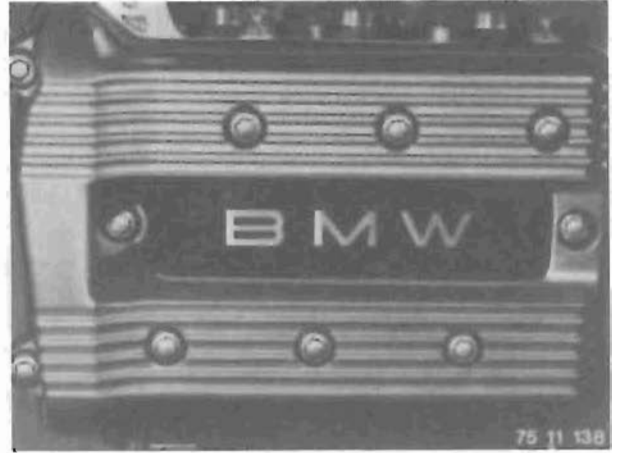

Crankcase end cover – removing

Slacken off the crankcase cover retaining screws and take off the crankcase cover.
Turn the engine round (camshafts at top).

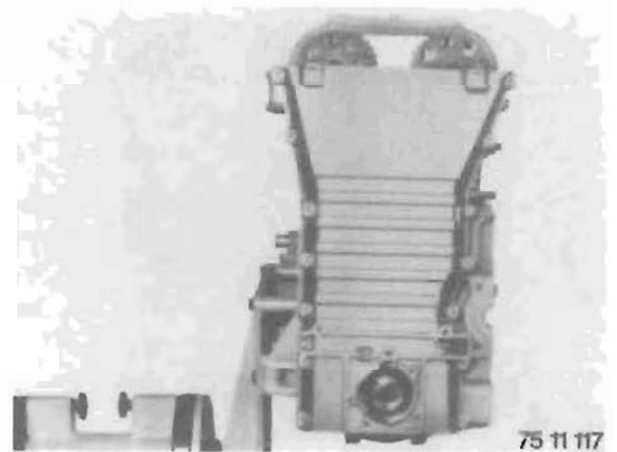

Hall-effect transmitter – removing

Slacken off the retaining screws (circles) and take off the cover for the Hall-effect transmitter with seal.

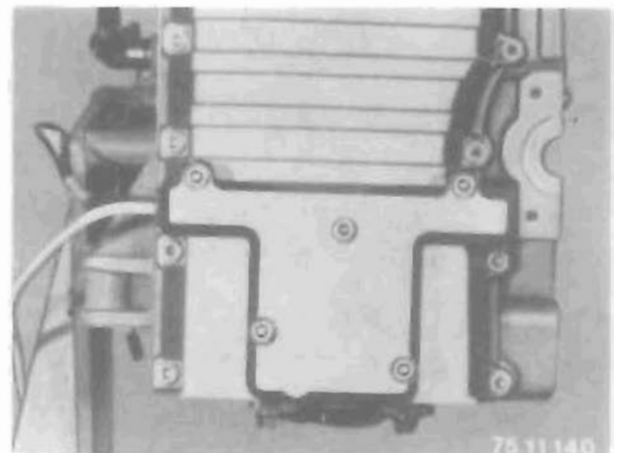

Slacken off the retaining screws (arrows) and take off the Hall-effect transmitter with cable.
Pull the oil pressure line out of the clip (1) and take it off.

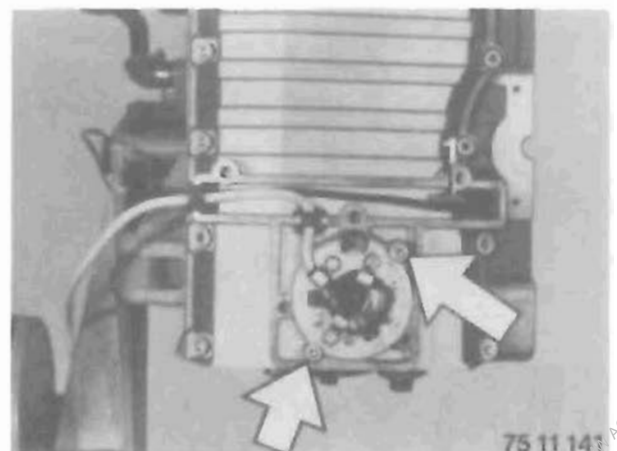

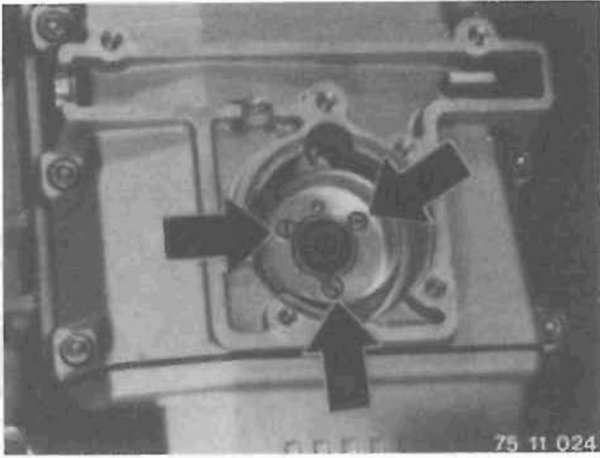

Gate rotor – removing

Slacken off the retaining screws (arrows).
Take out the gate rotor and top dead centre adjusting shim.

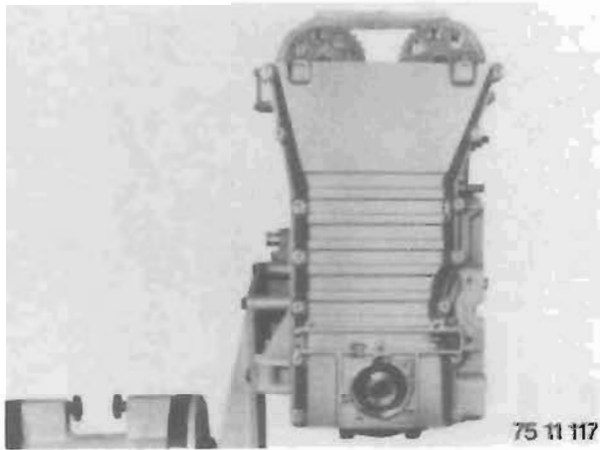

Timing case cover – removing

Remove the screws holding the timing case cover and take off the timing case cover.

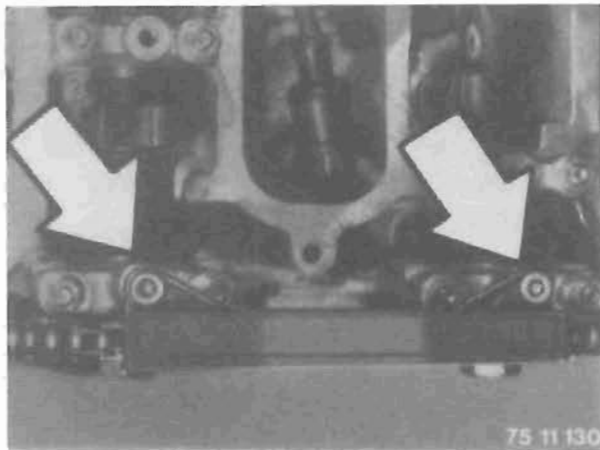

Control case – removing Sliding rail – removing

Slacken off the retaining screws (arrows) for the slider rail with BMW Torx insert 00 2 600 and take off the slider rail.

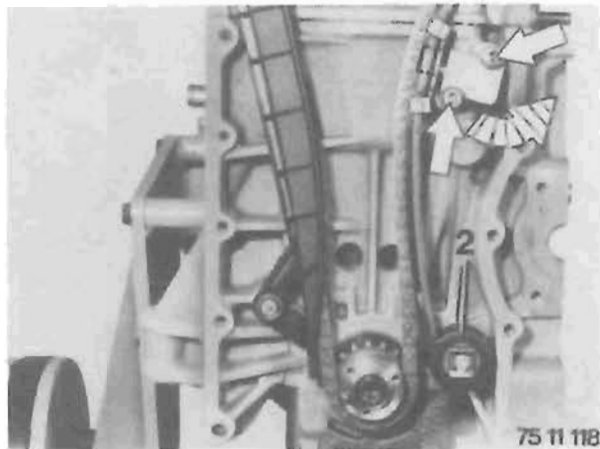

Chain tensioner – removing

Slacken off the retaining screws (arrows) for the chain tensioner.
Lift BMW tensioning device 11 5 500 (arrow) on to the chain tensioner and pull it up and out in the direction of the arrow.
Take off the retaining clip, washer (2) and slider rail.

Spark plugs – removing

Pull off the spark plug caps with universal pliers, gripping them at the tag.

Remove the spark plugs with BMW spark plug wrench 12 3 500.

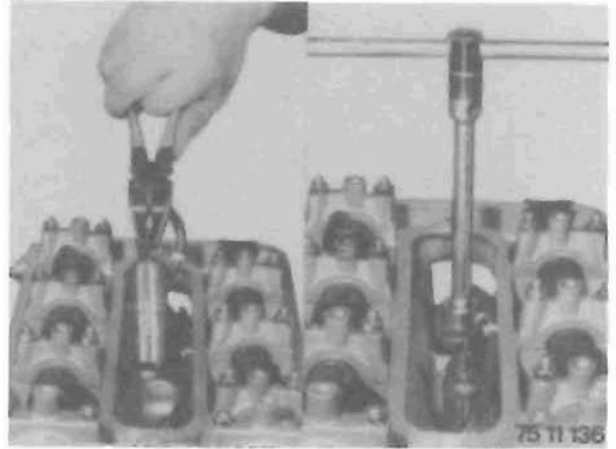

Chain sprockets – removing

Hold the camshaft hexagon with an open-ended wrench to prevent it from turning and slacken off the chain sprocket retaining bolts (arrow). Take off the chain sprockets.

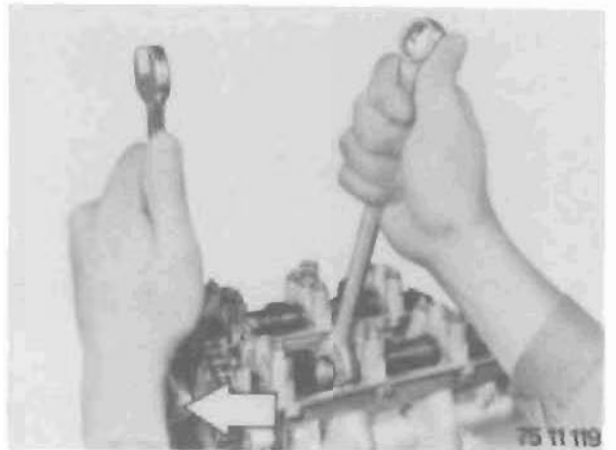

Chain guide rail – removing



Remove the circlip and washer (arrows) for the chain guide rail and take off the guide rail with the timing chain.



Remove the chain guide rail first, then the timing chain.

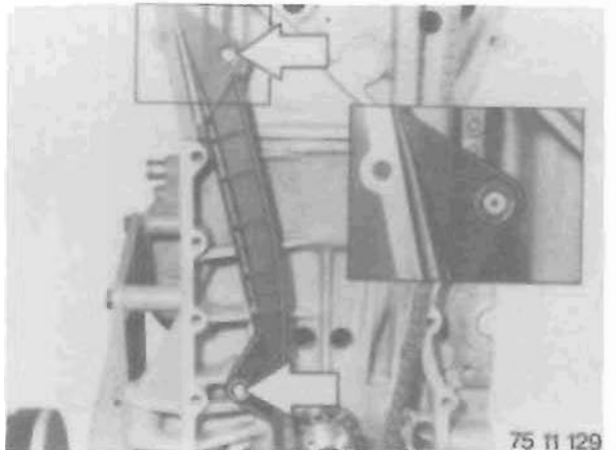

Camshaft – removing

Rotate the camshaft app. 45° beyond TDC (to prevent the valves from touching the piston).

Rotate the camshafts until there is no play at the cams/ tappets, e.g. the highest points on the cams face inwards. First slacken off the retaining screws for the front bearing mounts (arrows) and take them off (to prevent tilting). Slacken off the remaining screws securing the bearing mounts and take them off.

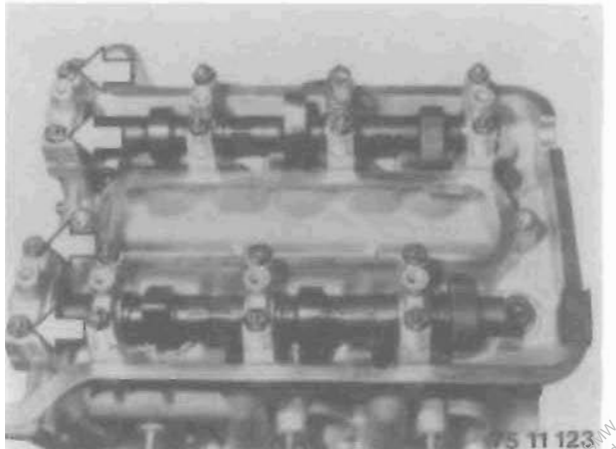

Cylinder head – removing (engine installed)

Carry out all steps marked * before removing the cylinder head.

- * Fuel tank – removing (see page 16–07.0)
- * Coolant – draining (see page 11–26.0)
- * Hose clips on thermostat housing – releasing (see page 11–27.0)
- * Throttle cable – detaching (see page 11–27.0)
- * Cable for increased starting speed – detaching (see page 11–27.0)
- * Ignition coil cover – removing (see page 11–28.0)
- * Cable connector for increased starting speed switch/frame wiring harness – detaching (see page 11–28.0)
- * Exhaust system – removing completely (see page 11–29.0)
- * Hose clip on air collector – detaching (see page 11–34.0)
- * Spark plug caps – removing (see page 11–34.0)
- Cover for water pump – removing (see page 11–37.0)
- * Rocker cover – removing (see page 11–39.0)
- * Cover for Hall-effect transmitter – removing (see page 11–39.0)
- * Timing case cover – removing (see page 11–40.0)
- * Timing chain – removing (see page 11–40.0)
- Spark plugs – removing (see page 11–41.0)
- * Camshaft – removing (see page 11–41.0)

Disconnect cable connectors between engine wiring harness and:

- * injector nozzles
- * butterfly valve switch.

Release the hose clip (1) on the coolant stub pipe. Pull off the hose.

Cylinder head – detaching

Unscrew the cylinder head retaining bolts.
Unscrew the retaining bolt (arrow) on the frame and take off the cylinder head.

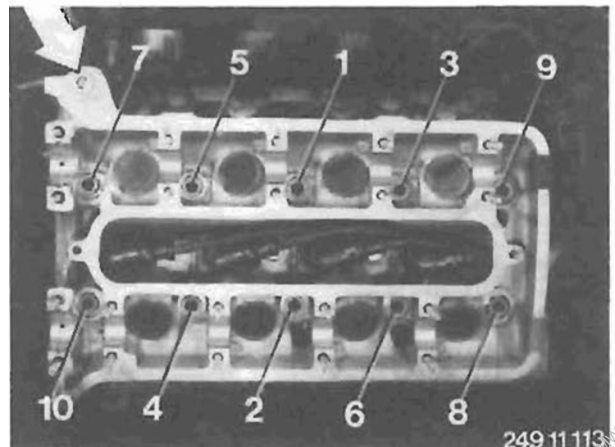

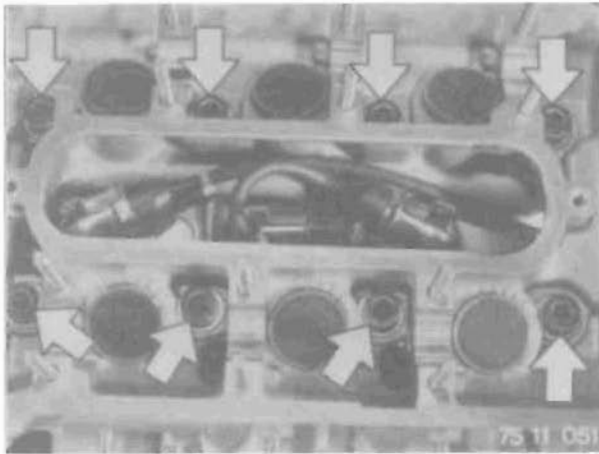

Cylinder head – removing

Unscrew and remove the cylinder head bolts (arrows) and take off the cylinder head.

Take off the cylinder head gasket.

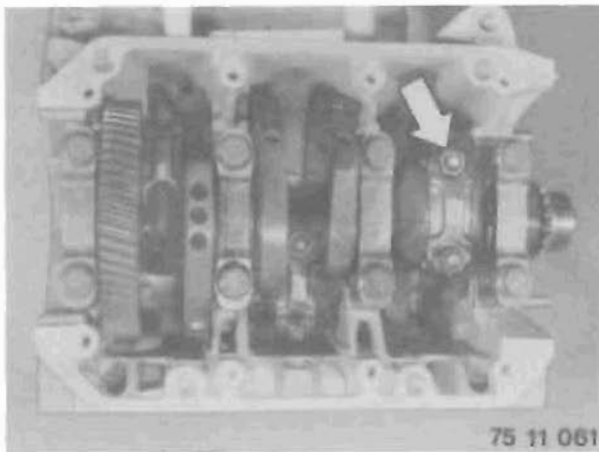

Pistons – removing

Turn the entire engine until crankshaft is at top.

Move the piston to bottom dead centre.

Unscrew the bearing cap retaining nuts (arrows) and take off the connecting rod bearing cap.

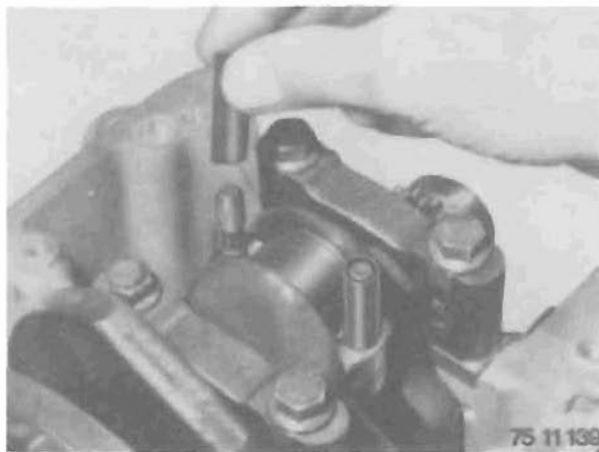

Cover the threads of the big end bearing bolt (e.g. with a short piece of rubber hose) to avoid damaging the big end bearings when removing the connecting rods.

Push the piston with connecting rod out of the cylinder with the handle of a hammer. Hold the piston as it comes out of the cylinder.

Turn the crankshaft further and repeat the procedures described above.

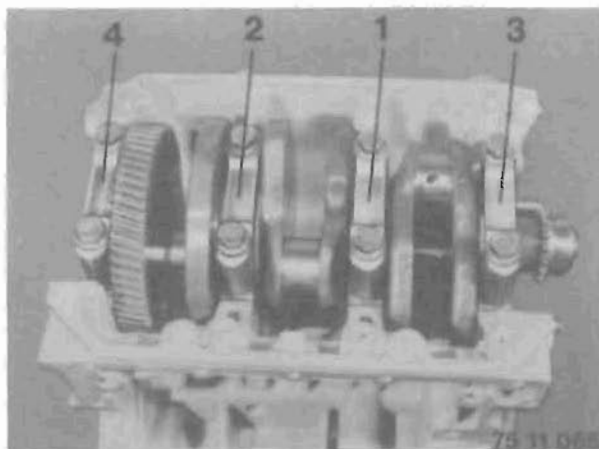

Crankshaft – removing

Slacken off the retaining screws for the big end bearing caps and take out the crankshaft.

Crankshaft – removing (engine installed)

Carry out all steps marked * before removing the cylinder head.

- * Fuel tank – removing 16–07.0
- * Coolant – draining 11–26.0
- * Cover for water pump – removing 11–37.0
- * Rocker cover – removing 11–39.0
- * Crankcase end cover – removing 11–39.0
- * Cover for Hall-effect transmitter – removing 11–39.0
- * Timing case cover – removing 11–40.0
- * Spark plugs – removing 11–41.0
- * Camshaft – removing 11–41.0

Big end bearing cap – removing

Bring pistons to top dead centre.
Release bearing cap retaining nuts (arrow).
Remove big end bearing cap.

Note:
Observe the instructions below.

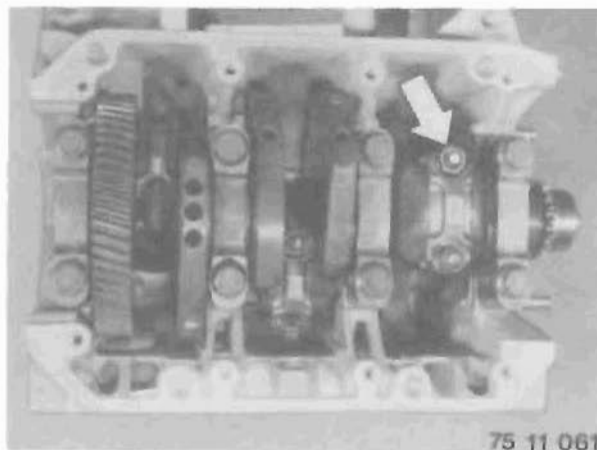

Cover the threads of the big end bearing bolt (e.g. with a piece of rubber hose for coolant stub pipe app. 100 mm long).

Note:



Turn piston of third cylinder to top dead centre.

Note:

The position of the crankshaft in relation to the output shaft must not be altered.



Turn piston of first cylinder to top dead centre.

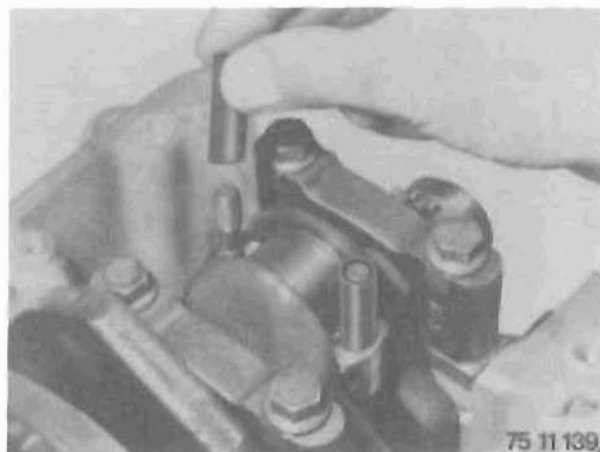

Remove the retaining screws for the big end bearing caps and take out the crankshaft.

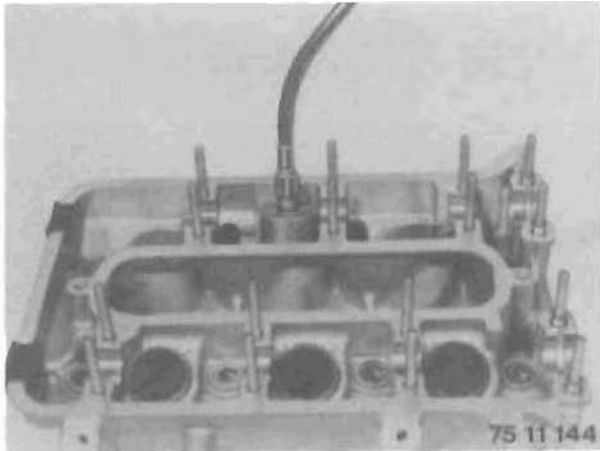

Cylinder head – stripping down

Carefully pull out the tappets, using a magnet.

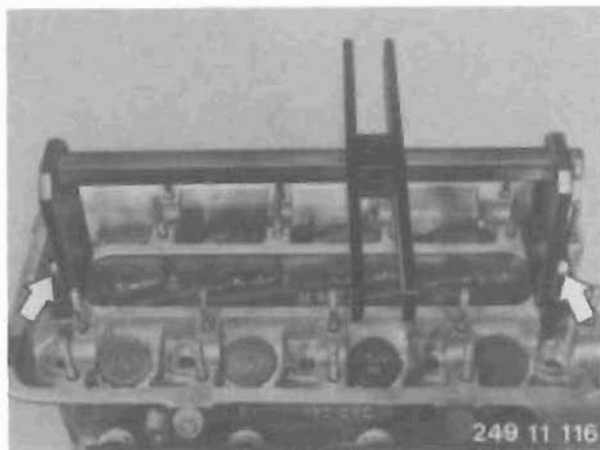

Attach BMW valve spring tensioner 11 1 740 with support 11 1 747 for three-cylinder engine.

Insert the pressure spindle with cage in the fixture. Turn the spindle to compress the valve spring until access is gained to the valve cone.

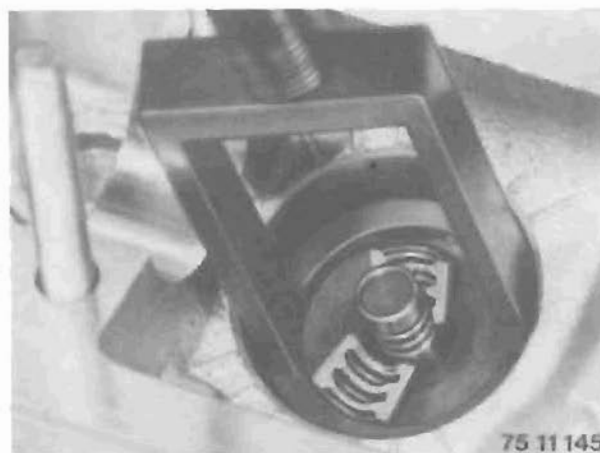

Take out the valve cone.

Turn the spindle back to slacken off the coil spring. Take out the cup spring at the top and the valve spring and spring plate at the bottom.

Examine the grooves in the valve stem for burrs (and remove if necessary with fine emery cloth).

Pull the valve out of the guide.

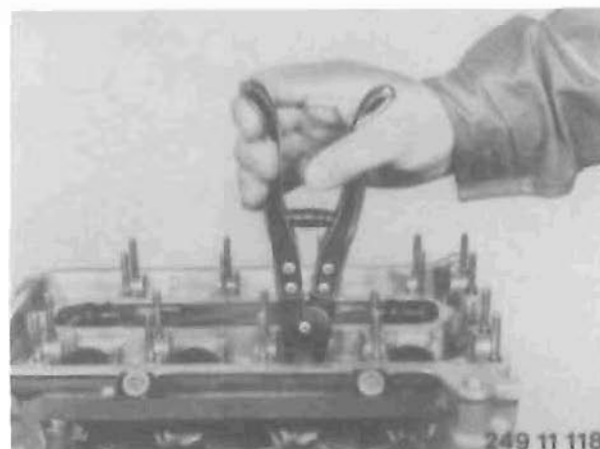

Valve stem seals – removing

Pull off the valve stem seals with BMW pliers 11 1 250.

Valve and valve seat – regrinding

H = minimum edge thickness

$\varnothing V$ = valve diameter

If dimension H is no longer present, the valve must be renewed.

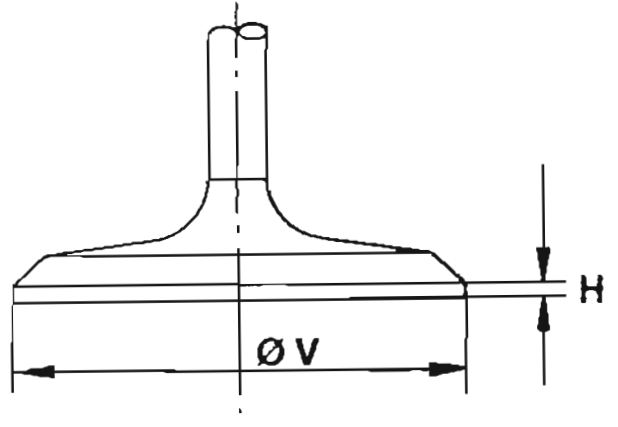

$\varnothing D$ = Valve seat diameter

B = Valve seat width

It is essential to maintain the valve seat width when regrinding.

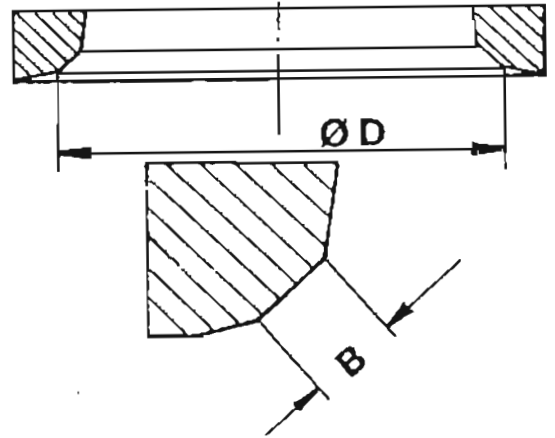

Regrind valve seats with the correct tool (BMW No. 00 3 520). Seats must not exhibit any chatter marks.

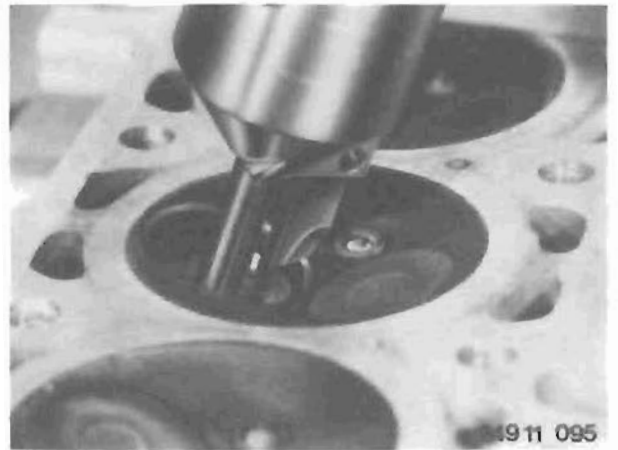

To check valves for leaks, fill the inlet and exhaust ports with fuel. No fuel should leak past the valve heads.

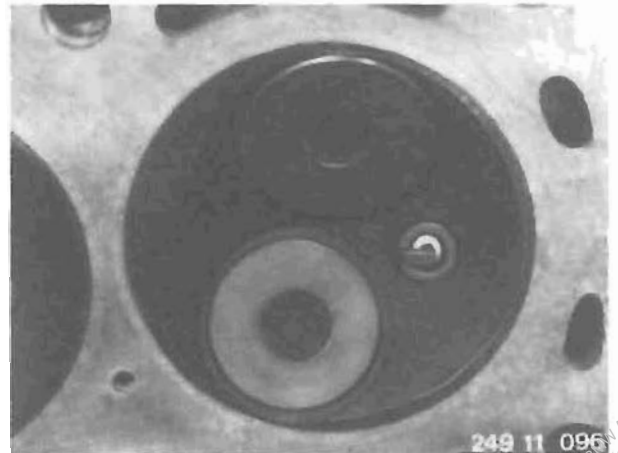

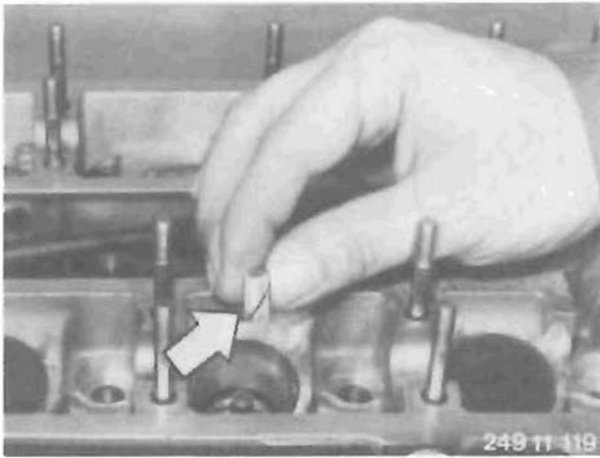

Valve stem seal – installing

Insert the valve before driving in the valve stem seal.

Push the plastic cap (arrow), BMW No. 11 1 350, on to the valve stem to avoid damaging the valve stem seal (rib on valve shaft).

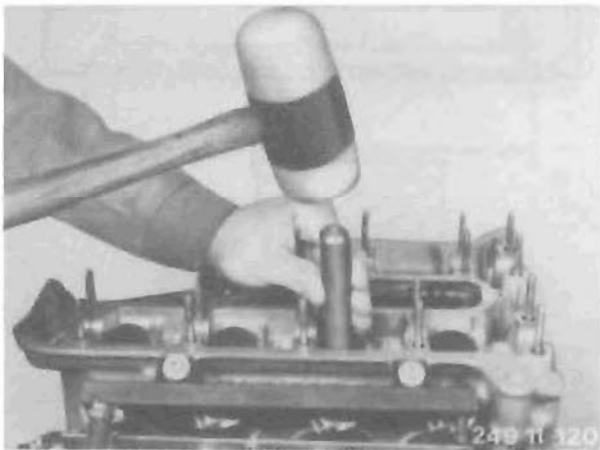

Drive in the valve stem seal with BMW arbor 11 1 940 until the arbor is in contact with the cylinder head.

Take off the plastic cap again.

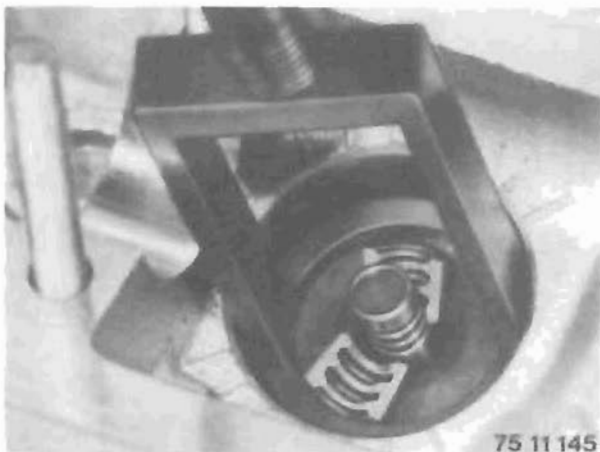

Cylinder head – assembling

Install the cup spring at the bottom and the valve spring and spring plate at the top.

Compress the spring with the spindle of BMW valve spring tensioner 11 1 740 until the grooves on the valve stem are revealed.

Install the valve cone and relieve the spring tension.

Note:

To avoid damaging the tappet bore holes, the spring tensioner cage must be centred in the tappet bore hole in each case.

Detach the valve spring tensioner again.

Lightly oil the tappets and carefully insert them in the cylinder head.

Combined water/oil pump

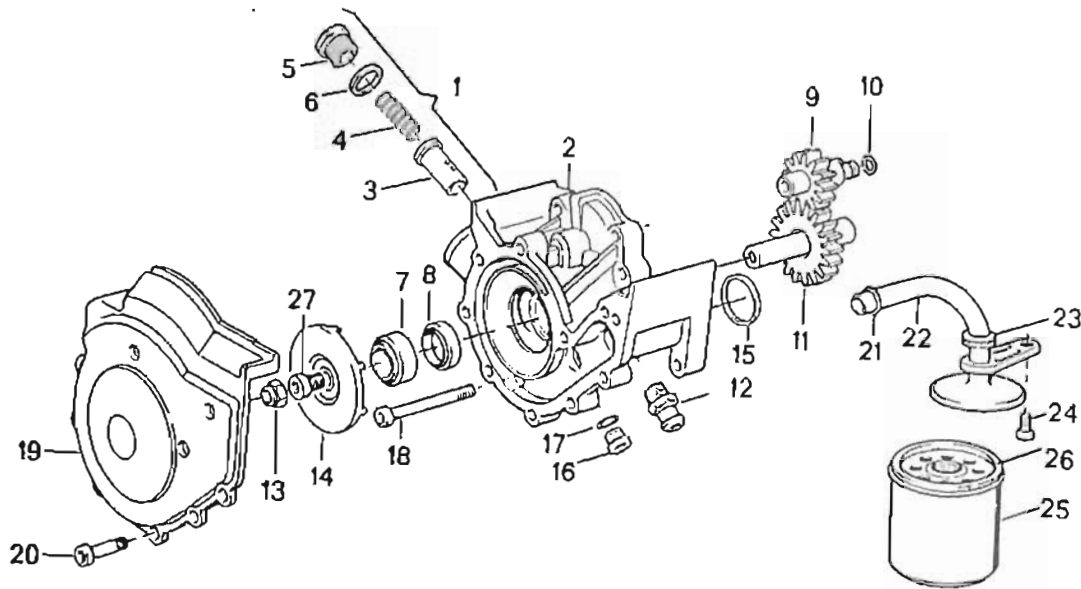

- 1 Pressure relief valve
- 2 Pump housing
- 3 Valve plunger
- 4 Spring
- 5 Screw plug
- 6 Sealing ring
- 7 Slipring seal
- 8 Shaft seal
- 9 Output shaft
- 10 O-ring
- 11 Shaft
- 12 Oil pressure switch
- 13 Nut
- 14 Water impeller

- 15 O-ring
- 16 Drain plug
- 17 Sealing ring
- 18 Retaining screw
- 19 Cover
- 20 Retaining screw
- 21 O-ring
- 22 Pipe
- 23 Sleeve
- 24 Retaining screw
- 25 Oil filter
- 26 O-ring
- 27 Retaining screw

Combined water/oil pump – stripping down

To slacken off the water pump impeller, hold the shaft with an Allen key.

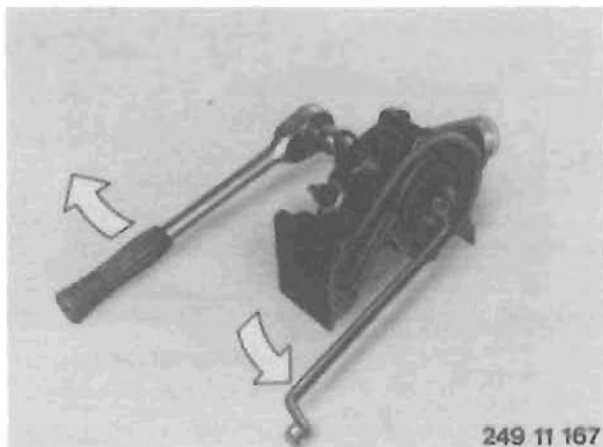

Apply light blows to the pump shaft with a plastic-face hammer and drive out the shaft. Take out the shaft and impeller.



Pull the sliding ring seal out of the pump housing with special pliers 11 1 250.

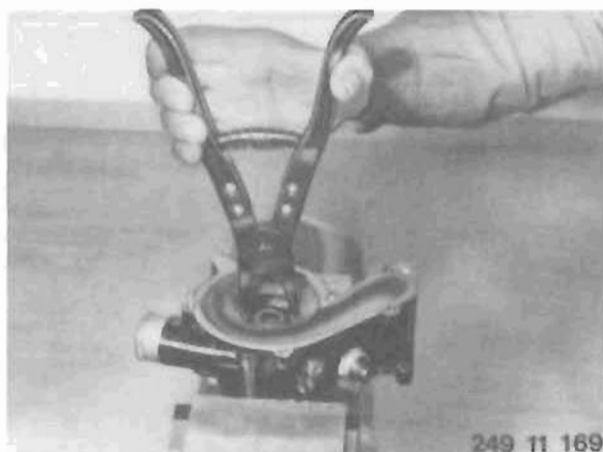

Carefully drive the shaft oil sealing ring out of the pump housing using a 5 mm screwdriver.

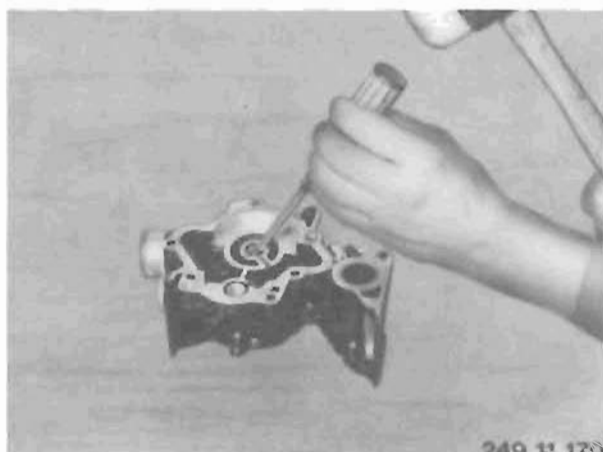

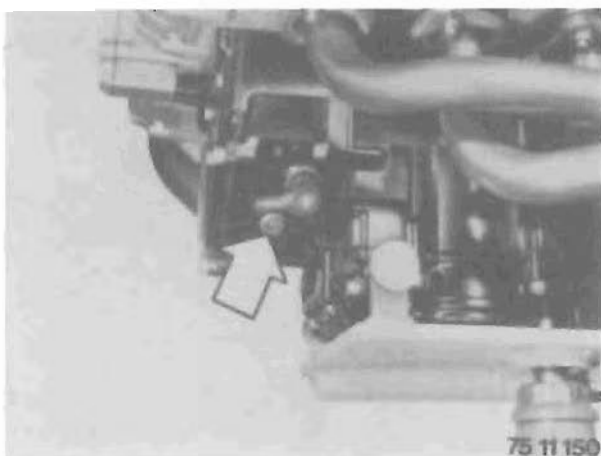

Oil pressure switch – removing and installing (With engine installed)

Pull off the electric lead to the oil pressure switch.
Remove oil pressure switch (12). Install oil pressure switch with new sealing ring.
Connect up the electric lead to the oil pressure switch.

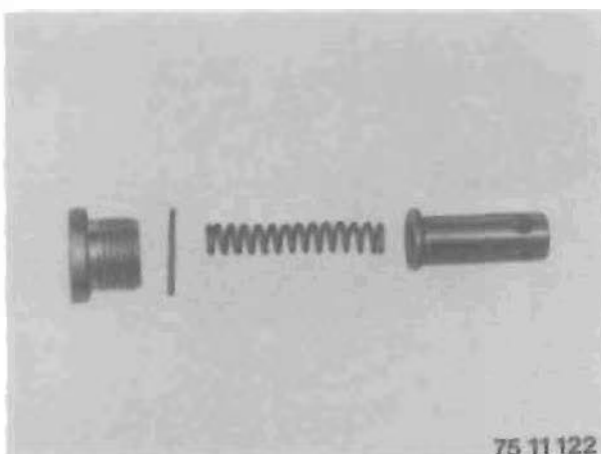

Pressure relief valve – removing

Slacken off the screw plug.
Remove the coil spring and valve plunger.
Examine the housing for score marks caused by the oil pump gears.
Check free movement of the valve plunger and examine the spring for signs of damage.

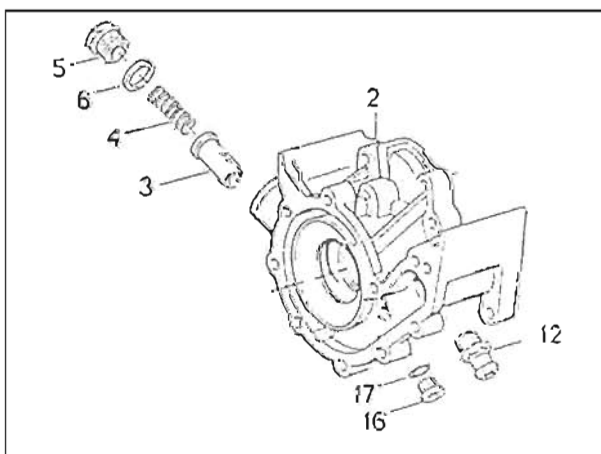

Combined water/oil pump – assembling

Screw in the pressure relief valve.
Slightly lubricate valve plunger (3) and insert in the pump housing.
Insert coil spring (4).
Insert screw plug (5) with new sealing ring (4) and tighten.
Screw in the coolant drain plug (16) with new sealing ring (17) and tighten.
Screw in the oil pressure switch (12) and tighten.

Tightening torque:

Screw plug:	35 ± 4 Nm
Drain plug:	9 ± 1 Nm
Oil pressure switch:	40 ± 5 Nm

Drive the shaft sealing ring as far as the stop in the pump housing with arbor 11 1 640 and arbor handle 00 5 500.

Note:

Note the correct installed position (see picture).

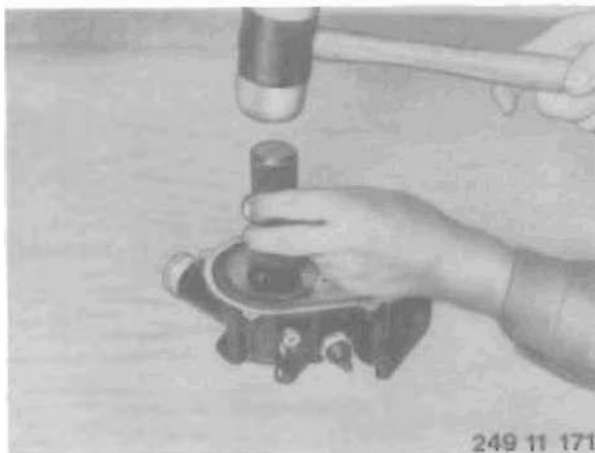

Pump shaft – installing

Note:

Avoid damaging the shaft sealing ring.

Drive in the sliding sealing ring as far as the seat with a suitable piece of tubing.

Note:

Make sure that the sliding sealing ring is always free of grease.

Warning:

Use only Genuine Part No. 11 51 12 64 466, manufactured by Goetze.

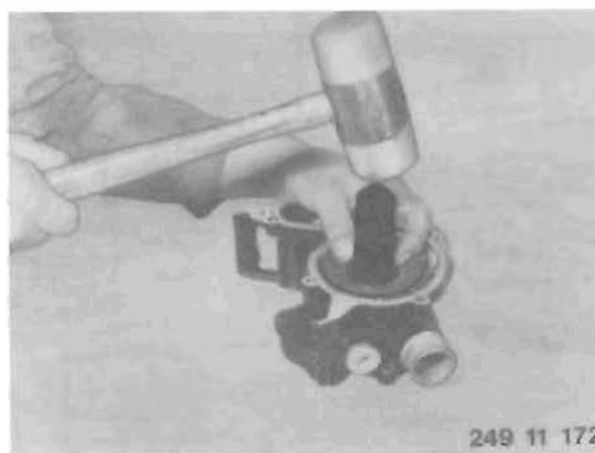

Fit the impeller on the shaft.

When securing, hold the shaft hexagon to prevent it from turning.

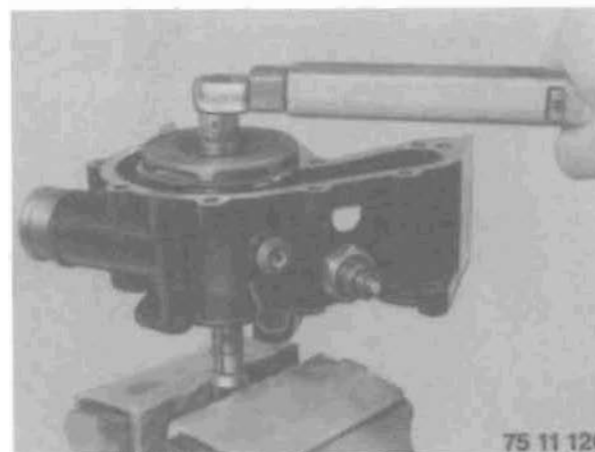

Tightening torque:

Water pump impeller to shaft:

Nut

$21 \pm 2 \text{ Nm}$

Bolt

$33 \pm 4 \text{ Nm}$

Intermediate flange

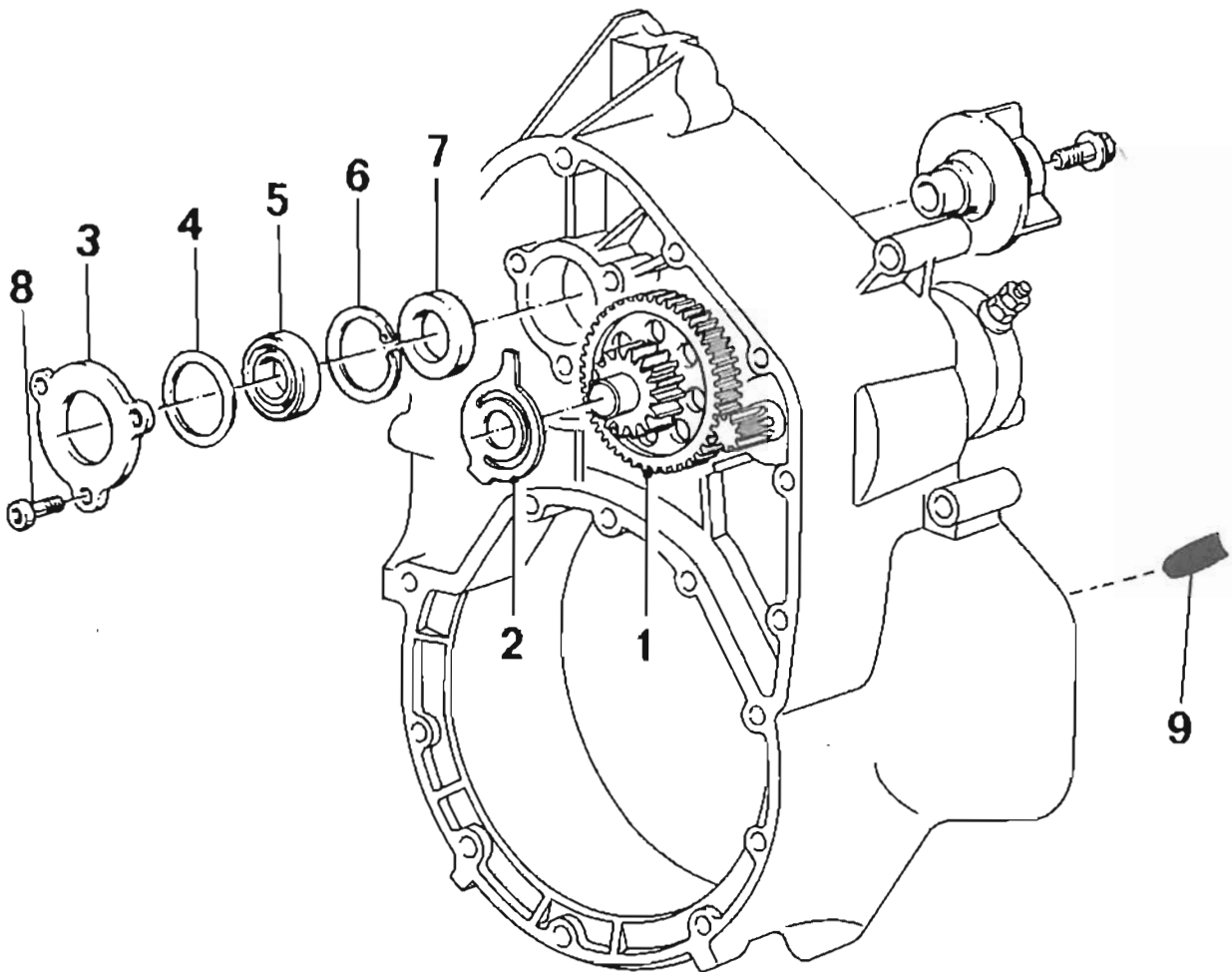

- 1 Countershaft
- 2 Spring
- 3 Stop plate
- 4 Cup spring
- 5 Ball bearing
- 6 Circlip
- 7 Shaft sealing ring
- 8 Retaining screw
- 9 Spacer

Intermediate flange – stripping down and assembling

Slacken off the retaining screws for the stop plate and take off the bearing plate.

Take out the cup spring.

Heat the intermediate flange to 100-120°C and pull out the ball bearing with BMW internal puller 00 8 570.

Take out the circlip with pliers.

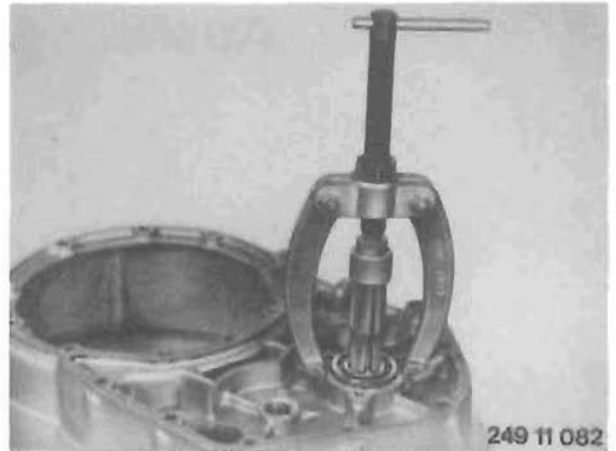

Shaft sealing ring – removing

Engine installed

The alternator and driver have been removed.

Pull out the shaft sealing ring with BMW internal puller 00 5 010 and the small thrust block from BMW universal puller 00 7 500.

Engine removed

Lever out the shaft sealing ring with a screwdriver that has been ground to a round end.

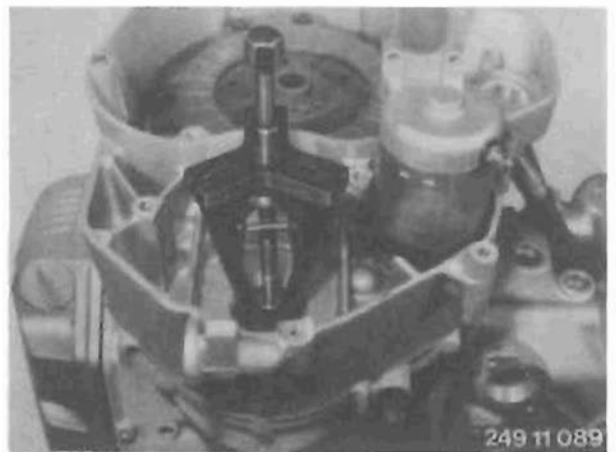

Pull out the spacer sleeves.

Drive in the new spacer sleeves (1) with a suitable arbor.

When installing:

Note projecting dimension X = 7–0.5 mm.

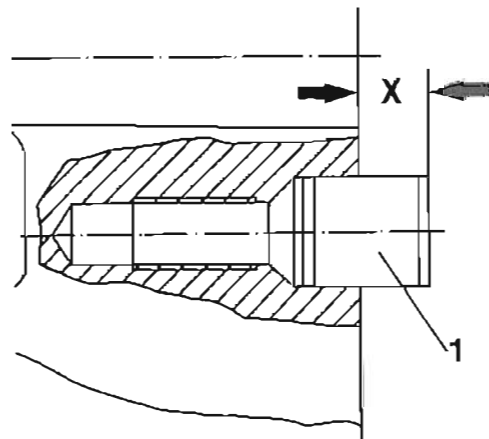

75 11 133

Insert circlip (1) with pliers.

Heat the intermediate flange to app. 100°C and press in ball bearing (2). Insert cup spring (3).

Note:

Note installed position (Y).

Clean Loctite from the threaded holes in the intermediate flange and also from the retaining screw threads.

Install stop plate (4) with bolts and Loctite 242.

Drive in shaft sealing ring (5) with BMW arbor 11 1 620 and handle 00 5 500 until it is flush.

Tightening torque:

Retaining bolts:

9 ± 1 Nm

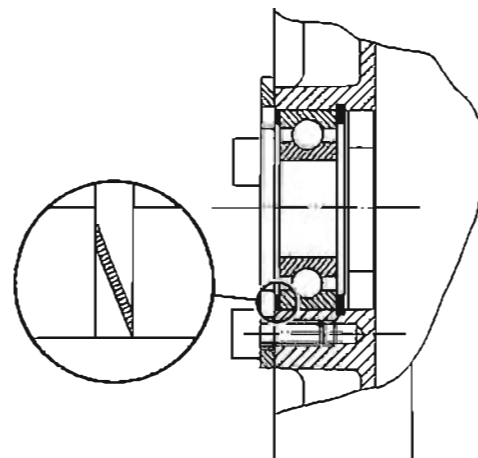

75 11 134

11-55.0

Auxiliary shaft with freewheel

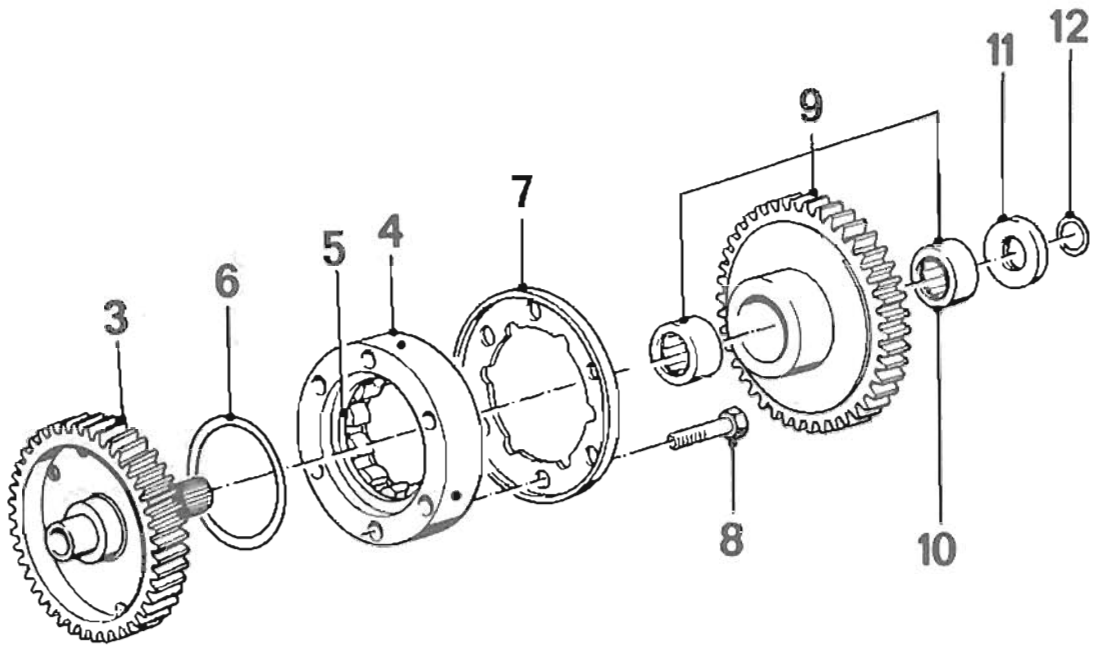

- 3 Auxiliary shaft
- 4 Freewheel cage
- 5 Freewheel outer ring
- 6 Cup spring
- 7 Cover plate

- 8 Retaining screw
- 9 Freewheel gear
- 10 Needle roller bearing
- 11 Washer
- 12 O-ring

Freewheel – stripping down

Take off the washer.

Pull the freewheel gear (arrow) off the auxiliary shaft.

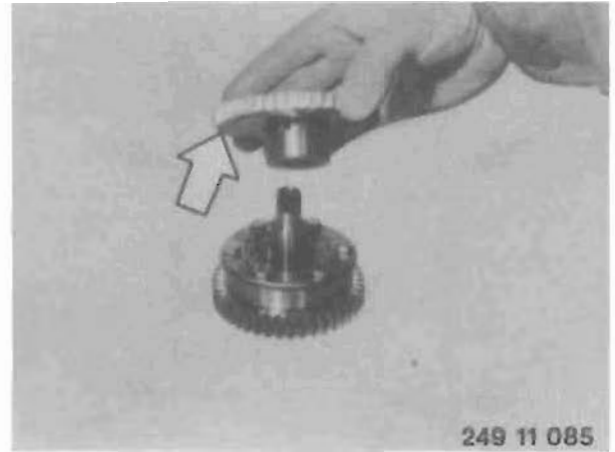

Secure the auxiliary shaft gear in a vice with aluminium jaws. Slacken off the retaining screws (arrows).

Strip the freewheel down to its individual components.

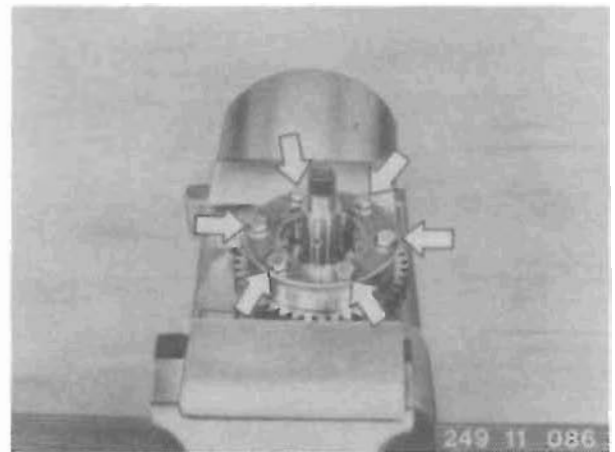

Components:

- 1 Auxiliary shaft
- 2 Cup spring
- 3 Freewheel cage
- 4 Freewheel outer ring
- 5 Cover plate

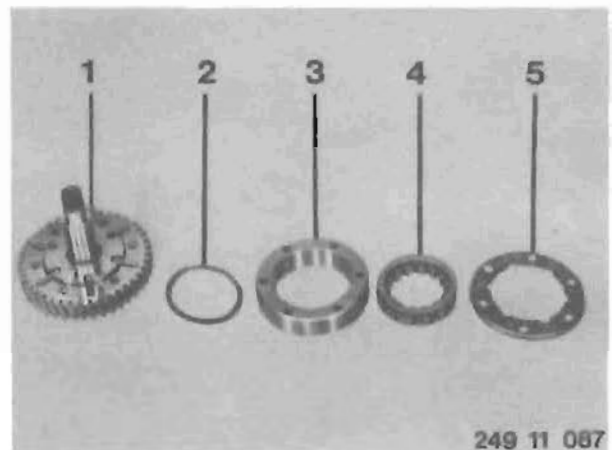

Pull out the needle roller bearing using BMW internal puller 00 8 570.



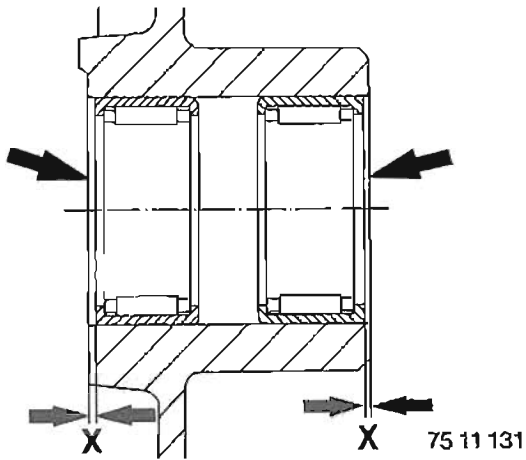

Freewheel – assembling

When installing:

Press in the needle roller bearing with the lettering (arrow) facing outwards.

Dimension $x = 0.4 \pm 0.2$ mm.

Assembly sequence:

Note:

Note the correct installed position of the cup spring (see picture).

Apply a generous coat of engine oil to the freewheel cage. Install the freewheel outer ring in such a way that the clamp springs face towards the cover plate.

Tightening torque:

Retaining screws

9 ± 1 Nm

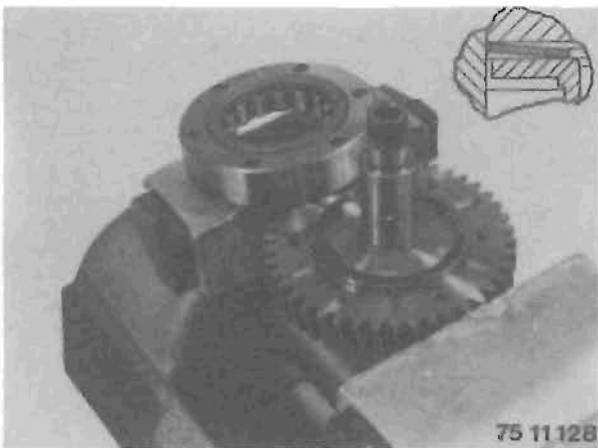

Push the freewheel gear (arrow) on to the auxiliary shaft by rotating it in a clockwise direction.

Install the washer and O-ring.

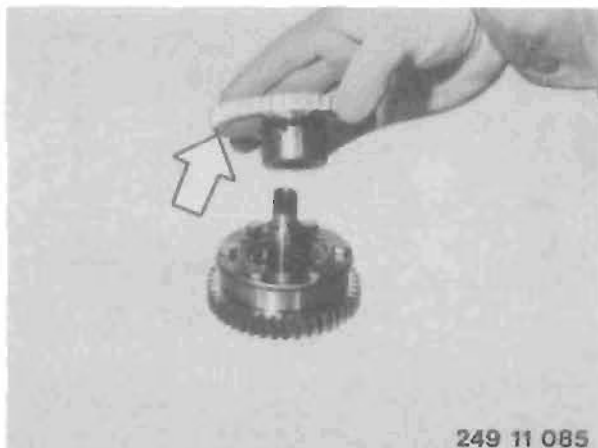

Needle roller bearing for auxiliary shaft in crankcase – removing

Heat the locating point for the bearing in the crankshaft to 100-120°C and pull out the needle roller bearing with BMW internal puller 00 8 570.

When installing:

Heat the locating point to 100-120°C and drive in the needle roller bearing with the lettering facing outwards, using a soft metal arbor (20.5 mm dia.).

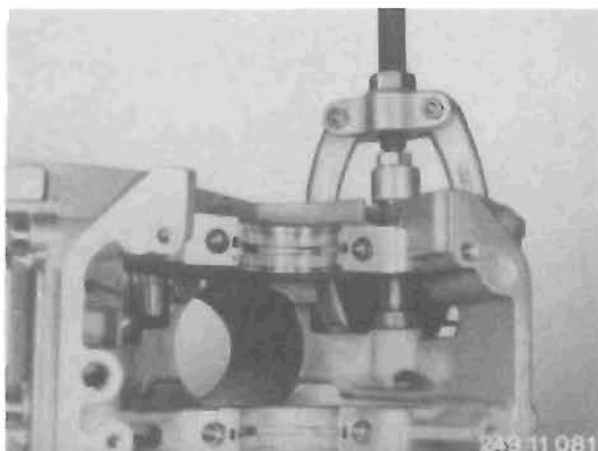

Chain tensioner – stripping down and assembling

Individual components of chain tensioner:



- 1 Guide with piston
- 2 Spring
- 3 Housing
- 4 Spring and ball

Assemble in the sequence illustrated.

Turn the housing through 90° and compress the chain tensioner.

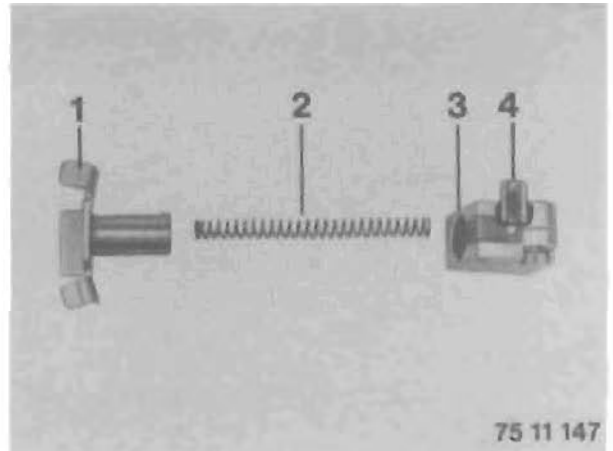

- 1 Guide with piston
- 2 Spring
- 3 Tensioning sleeve
- 4 Housing

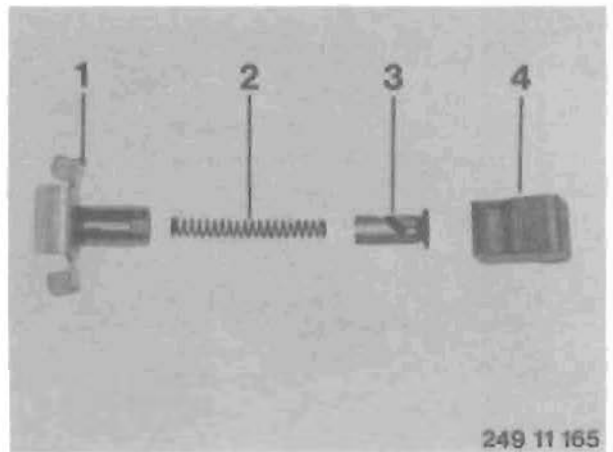

Hold the chain tensioner together with BMW tensioner 11 5 500.

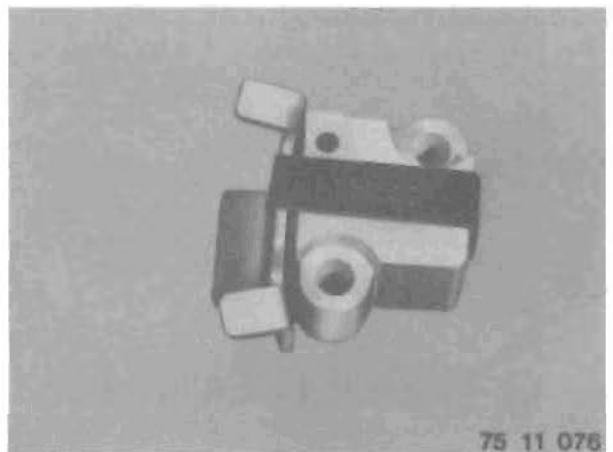

Tensioning rail – removing

Lift the tensioning rail at the lugs (arrows) with a small screwdriver.

Push the tensioning rail out of the eye (1) and pull it off the guide (2).

Install by following the same procedure but in the reverse sequence.

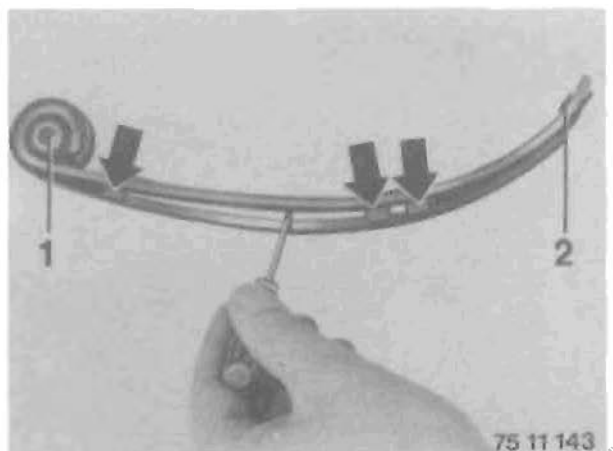

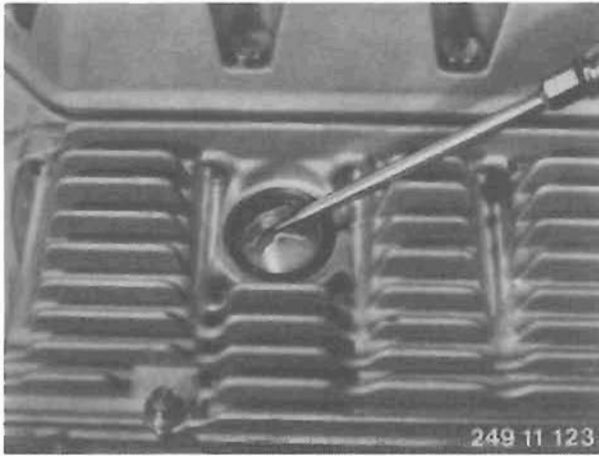

Oil level sight glass – removing and installing

With the sight glass installed, drain off the engine oil until the level is below the sight glass. Alternatively, tip the motorcycle to one side.

Lever out the oil level sight glass with a large screwdriver.

Note:

Be careful not to damage the cooling fins (place a cloth or similar underneath). If splinters should fall into the crankcase, detach the oil sump and remove the splinters.

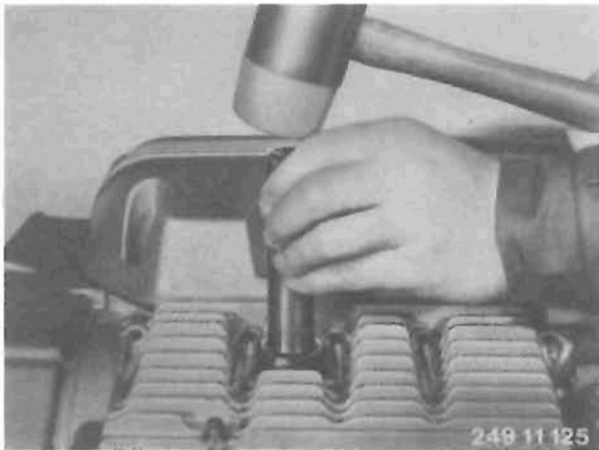

Before installing the new sight glass, apply HD engine oil to the external thread. Drive in with BMW arbor 00 5 550.

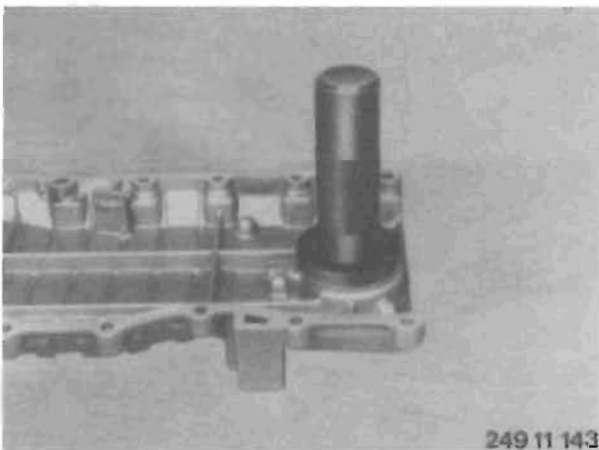

Shaft sealing ring in chaincase cover – removing and installing

The chaincase cover has been removed.

Drive out the shaft sealing ring.

Drive in the new shaft sealing ring with BMW arbor 11 1 610 and handle 00 5 500.

Piston – stripping down

Lever out the circlip with a small screwdriver.
Drive out the gudgeon pin with BMW arbor 11 2 930.

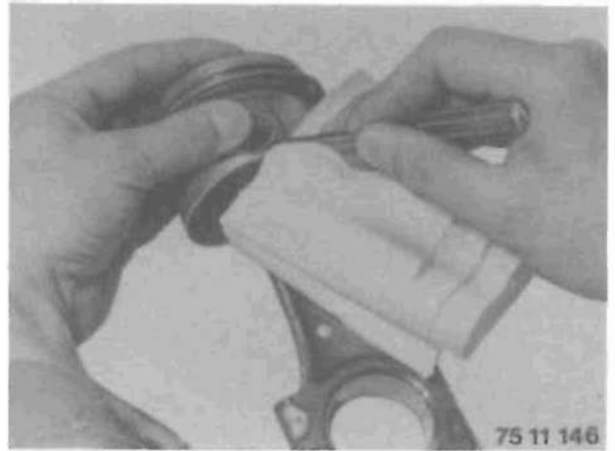

Carefully take the piston rings out of the groove with piston ring pliers.



Piston – measuring

Note:
Expose the arrow on the piston crown denoting the installed position.
Carefully scrape off any carbon deposits, also cleaning out the valve pockets.

Measure the piston diameter at the piston skirt with a micrometer (see illustration).

Make:	Dimension "A"
KS	12.0 mm
Mahle	7.6 mm



Measure the piston ring flank clearance with a feeler gauge.
For flank clearance, see Specifications, page 11 – 09.0.

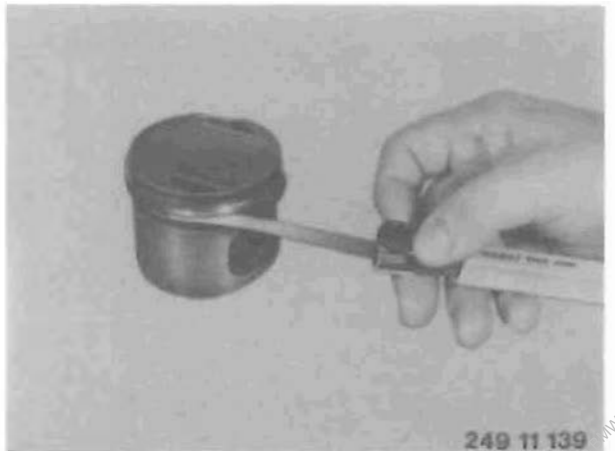

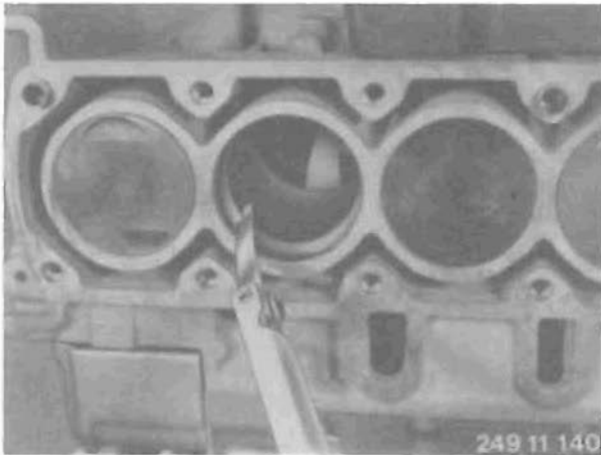

Measure the piston ring gap in the cylinder.

Rectangular-section ring (groove 1)

Rectangular-section ring (groove 2)

Penthouse-pattern ring (groove 3)

For permitted ring gap, see Specifications, page 11 – 09.0.

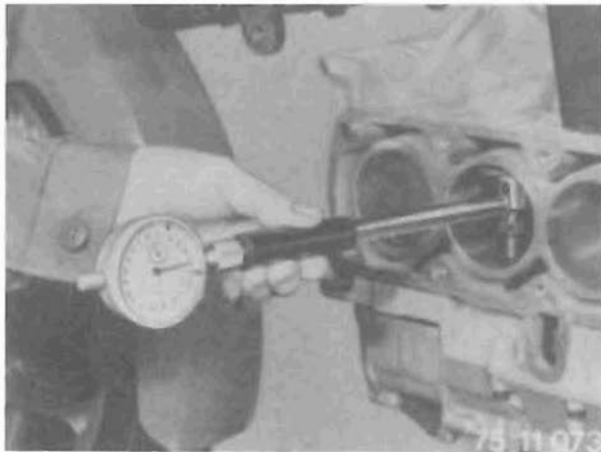

Cylinder – measuring

Fit the internal measuring instrument to the micrometer.

Measure the cylinder bore at three positions in a crosswise pattern. Make a note of the dimensions.

Measuring planes:

In travel direction → and at right-angles to the travel direction ↓.

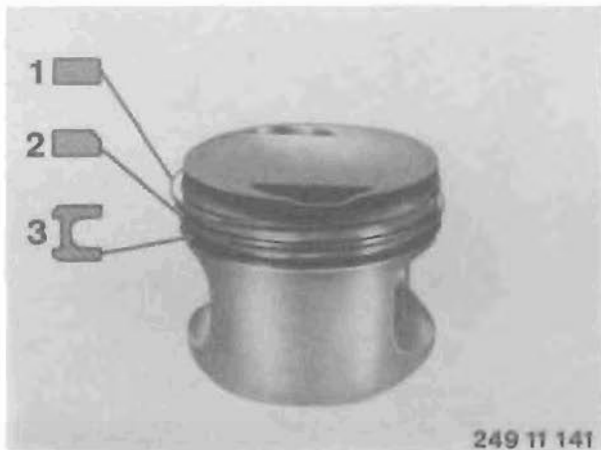

Piston – assembling

Carefully install the piston rings using piston ring pliers. Refer to the illustration for the correct direction of installation.

1 Rectangular-section ring

2 Rectangular-section ring

3 Tubular-spring loaded penthouse-pattern ring

Note:

Gap between tubular spring and penthouse-pattern ring offset by 180°.

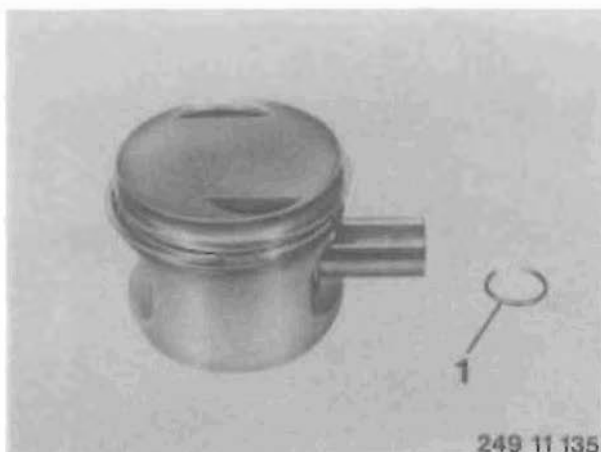

The gudgeon pin belongs to a specific piston and must not be interchanged.

Use only pistons from the same manufacturer and of the same weight group.

Important:

Use gudgeon pin keepers once only.

Small end bushing – removing and installing

Press out the old small end bushing.

When installing:

The new small end bushing gap must be offset by 60° to the left or right of the bushing axis.

Drill and deburr the oil bore.

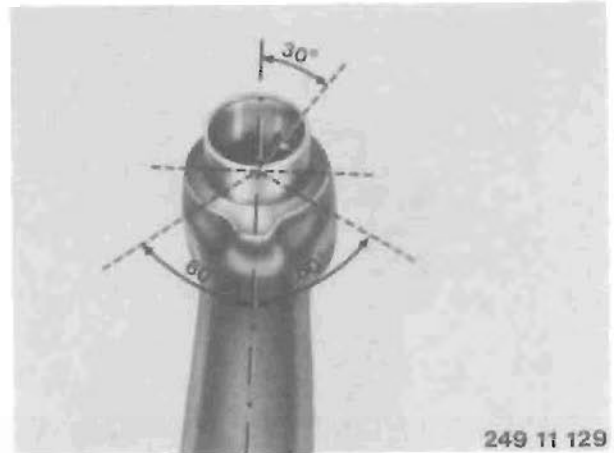

Ream the small end bushing.

Note:

The gudgeon pin should slide easily through the small end bushing when only slight pressure is applied.

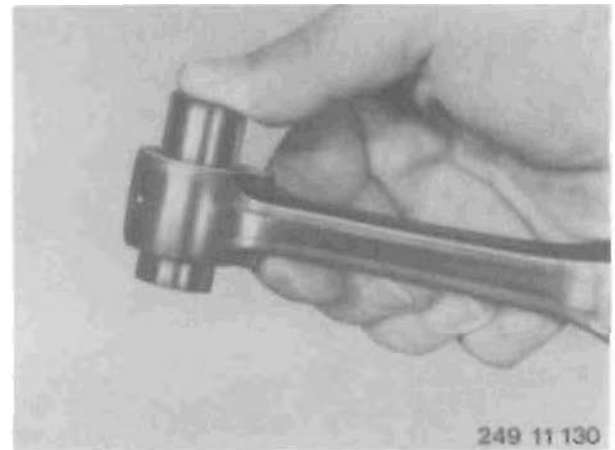

Check that the two connecting rod holes are parallel:

The measured difference along test length (P) must not be greater than 0.06 mm.

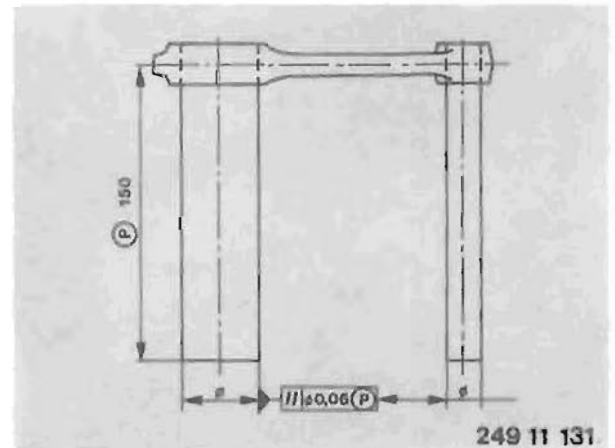

Piston and connecting rod – assembling

Note the connecting rod weight tolerance.

For values, see Specifications, page 11–09.0.

Note:

Installed position: oil bore at top

Looking in the direction of travel, the arrow on the piston crown points to the front.

Use only pistons from the same manufacturer and of the same weight group.

Important:

Use gudgeon pin keepers once only.

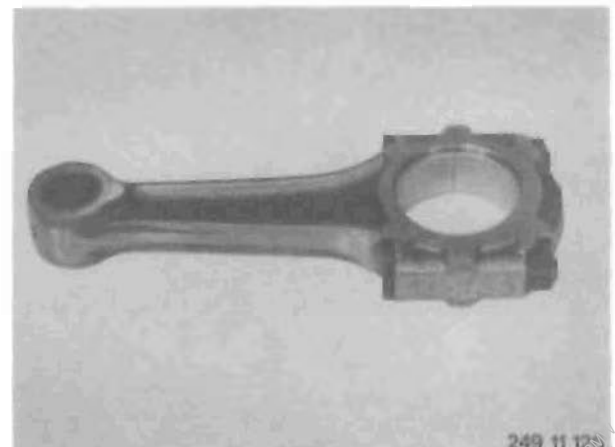

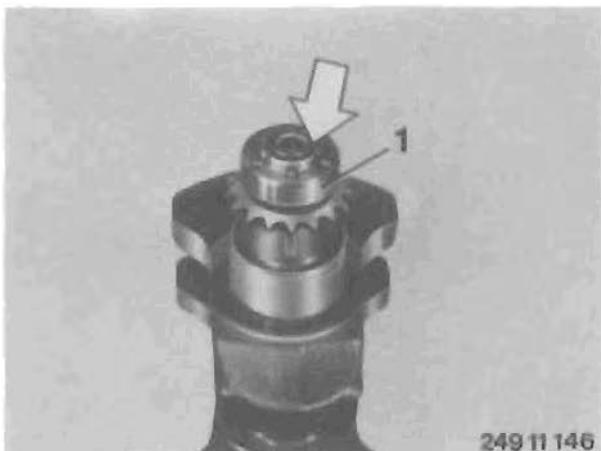

Crankshaft pinion and rotor flange – removing and installing

Slacken off the retaining screw (arrow) for the crankshaft pinion and rotor flange.
Apply light blows to the rotor flange (1) and pull it off. Take off the pinion.
Install by following the same procedure but in the reverse sequence.

Tightening torque:
Retaining screws

$50 \pm 6 \text{ Nm}$

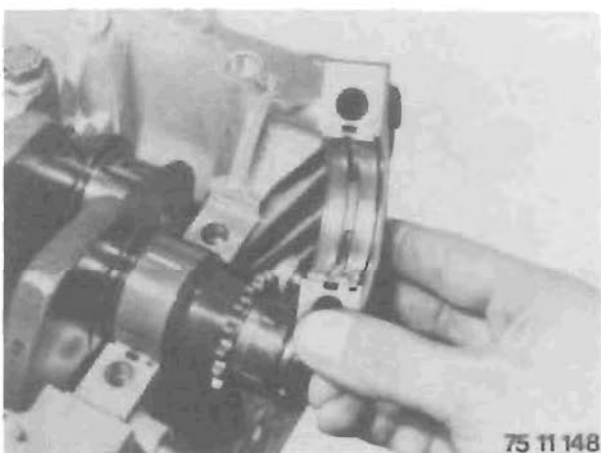

Big end bearing play – measuring

Measure each bearing separately.
Take off the bearing cap. Use Type PG-1 Plastigage BMW No. 00 2 590 to read off the bearing play measurement. Turn the crankshaft to bottom dead centre and then advance or turn back through 30° . Wipe off oil from the bearing journal and bearing shell. Place the Plastigage thread (arrow) over the entire width of the bearing 6-8 mm from the centre. Fit bearing cap and tighten to the specified torque. **The crankshaft must not be rotated now.**

Tightening torque:
Bearing cap

$50 \pm 6 \text{ Nm}$

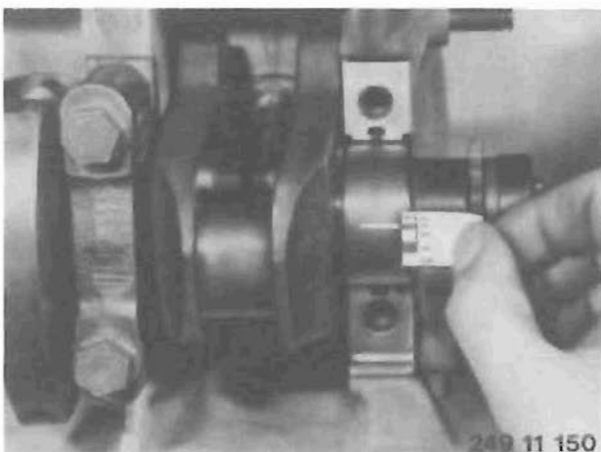

Remove the bearing cap again and measure the width of the plastic thread against the scale to determine the amount of bearing play.

For bearing play values, see Specifications, page 11–08.0.

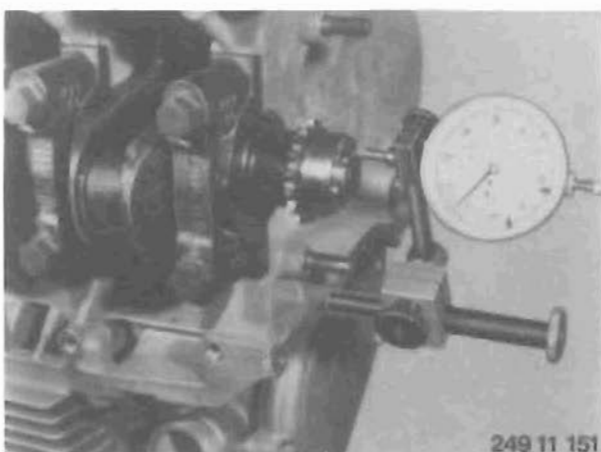

Attach BMW measuring device 00 2 500 to the threaded hole for the timing case cover.

Move the crankshaft to and fro with a large screwdriver to determine the amount of axial play.

For axial play values, see Specifications, page 11–08.0.

Crankshaft – measuring

If bearing play is found to be excessive, the crankshaft must be re-measured.

The production tolerance of the shaft is divided up into three colour zones.

See Specifications, page 11 – 08.0.

The crankshaft and bearings belong together; note the same colour markings.

Note:

If the main bearing points are reground, they must subsequently be hardened and finished.

Only standard grade “0” is available as a replacement.

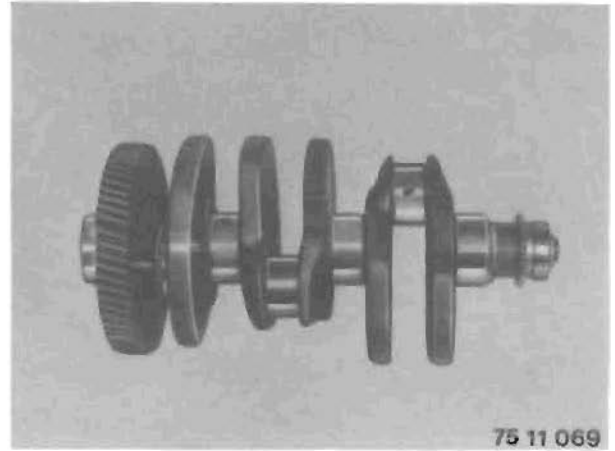

Crankshaft – installing

Install the crankshaft with bearing shells (lightly lubricated) groove to groove.

See illustration for sequence. 

Cylinder 1 and 2 are marked.
Bearing 1 is at the timing end of the engine.
Thrust and No. 4 bearings are not marked.

See illustration for sequence. 

Bearings 1, 2 and 3 are marked.
Cylinder 1 is at the timing end of the engine.
Thrust and No. 5 bearings are not marked.

Tightening torque:

Bearing cap

50 ± 6 Nm

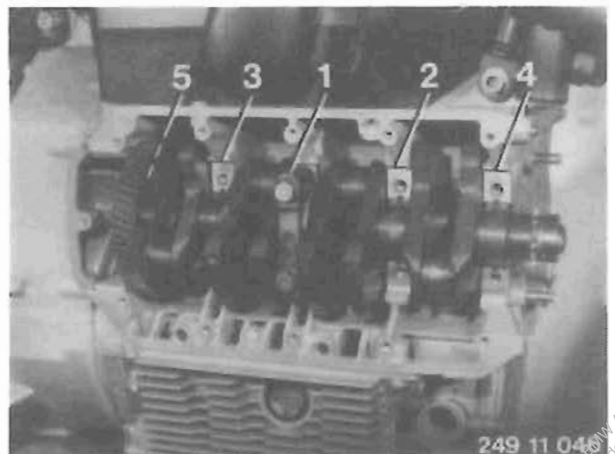
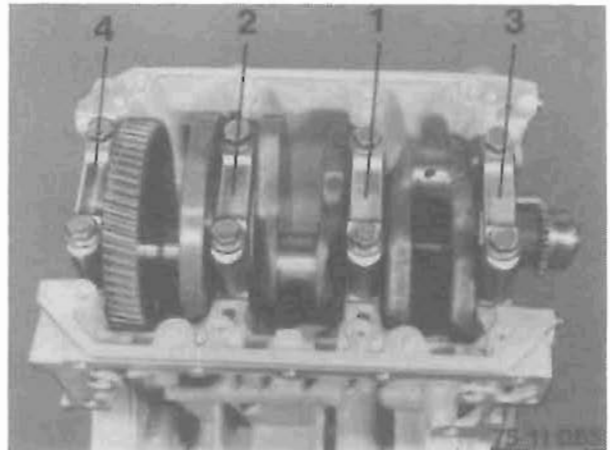

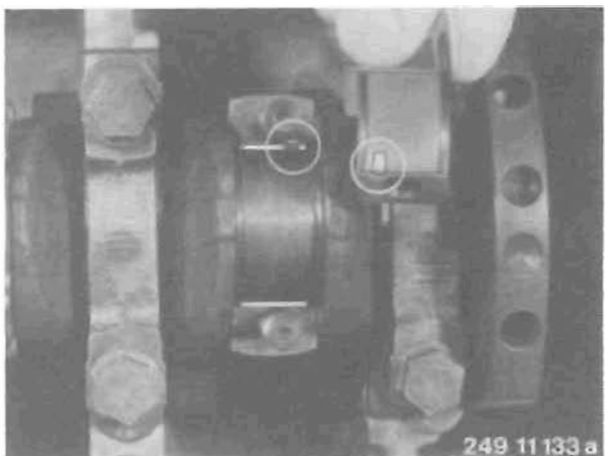

Big end bearing play – measuring

Each bearing must be measured individually. Measure bearing play using Type PG-1 Plastigage BMW No. 00 2 550. Displace crankpin app. 30° from bottom dead centre. Wipe away oil from crankpin. Place the Plastigage thread across the entire width of the bearing 6-8 mm from the crankpin centre. Install the bearing shells groove to groove. **The crankshaft must not be rotated after this.**

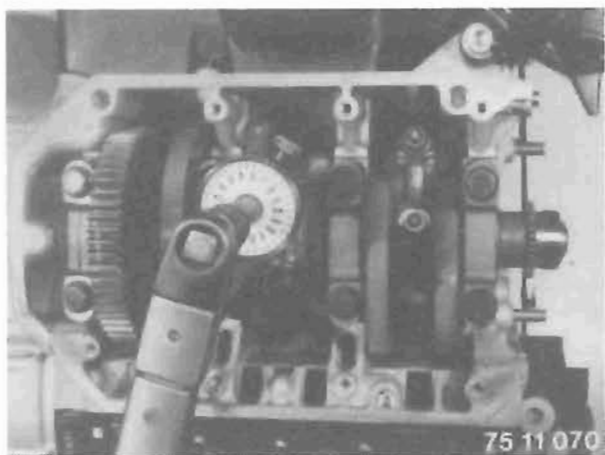

Apply torque to the big end bearing shells and tighten with BMW tightening angle indicator 11 2 110.

Note:
The crankshaft **must not be rotated** now.

Tightening torque:

Connecting rod bearing cap nut	$30 \pm 3 \text{ Nm}$
Angle	$80^\circ \pm 3^\circ$

Remove the bearing cap again and measure the width of the plastic thread against the scale to determine the amount of bearing play. For permissible bearing play values, see Specifications, page 11–08.0.

If the big end bearings need to be renewed, ensure that the colour marking on the crankpins and big end bearings match.

Crankshaft – installing (with engine installed)



Insert crankshaft in such a way that the marks (circle) correspond.



Install the crankshaft as it was removed.

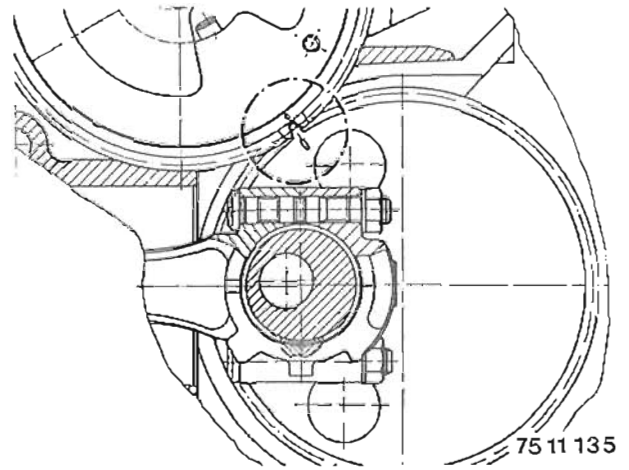

Insert bearing covers groove to groove.
Tighten retaining screws, working from the inside outwards.

Note:

(Bearing 1 is at the front, viewed in the direction of travel)
The bearing covers are stamped with numbers.
The thrust and final bearings are not marked.

Once the crankshaft has been installed, the following procedures must be carried out.

- * Timing chain – installing (see page 11 – 80.0)
- * Chain tensioners – installing (see page 11 – 80.0)
- * Timing case cover – installing (see page 11 – 82.0)
- * Cover for water pump – installing (see page 11 – 83.0)

only

- * Hall-effect transmitter – installing (see page 11 – 83.0)
- * Crankcase cover – installing (see page 11 – 86.0)
- * Cylinder head cover – installing (see page 11 – 87.0)
- * Coolant – adding (see page 11 – 94.0)
- * Fuel tank – installing (see page 16 – 07.0)

Output shaft

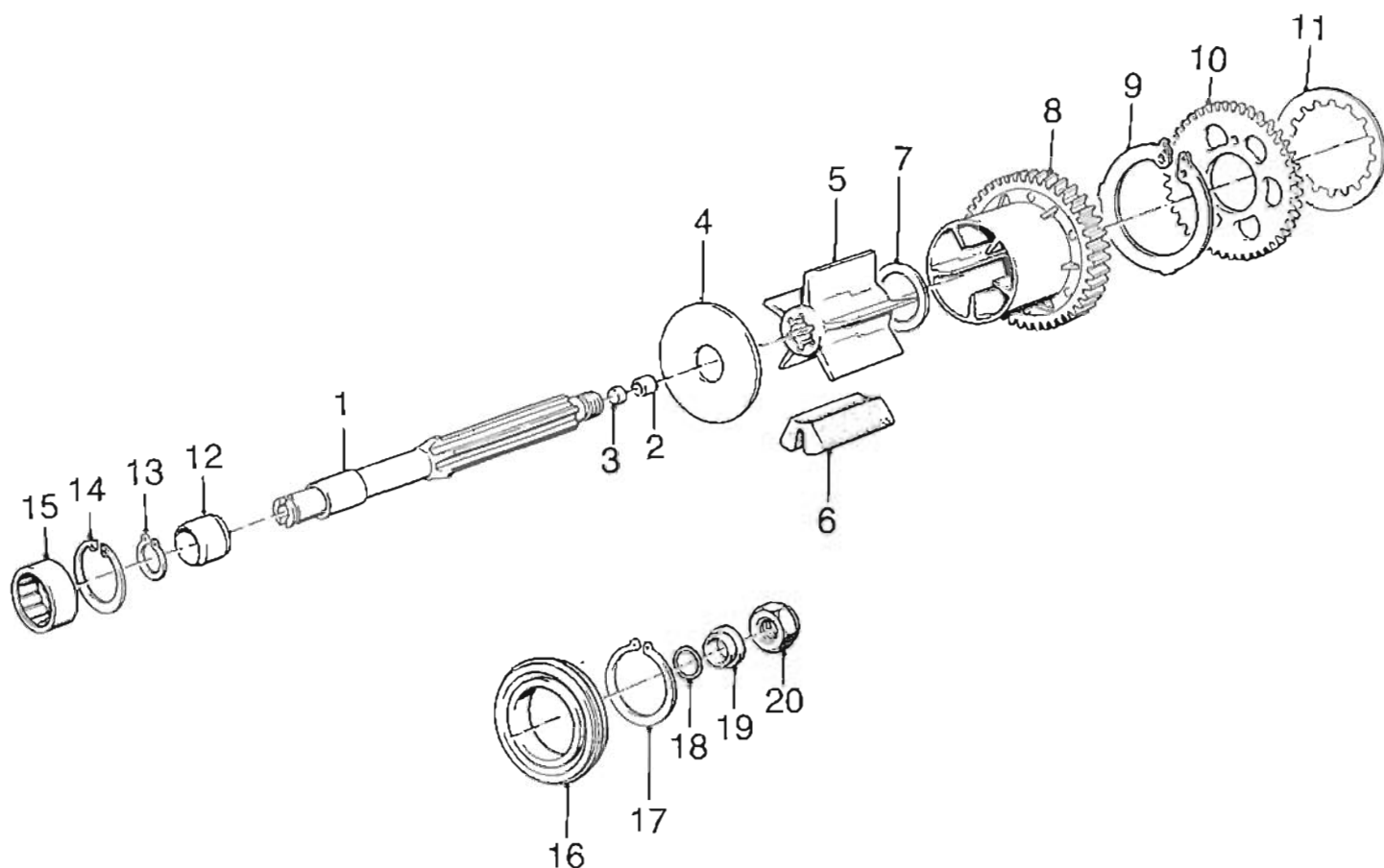
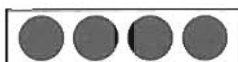

- | | |
|-----------------------|-----------------------------|
| 1 Output shaft | 11 Cup spring |
| 2 Bushing | 12 Bearing inner ring |
| 3 Stop cover | 13 Snap ring |
| 4 Retaining plate | 14 Snap ring |
| 5 Damper | 15 Needle roller race |
| 6 Rubber damper block | 16 Deep-groove ball bearing |
| 7 Stop plate | 17 Snap ring |
| 8 Damper housing | 18 O-ring |
| 9 Spring | 19 Thrust piece |
| 10 Tensioning gear | 20 Hex nut |

Output shaft – stripping down

Identifying feature: ball bearing with axial locking (ring or shoulder) and cup spring.
Output shaft is removed.
Pull pinion for oil and water pump drive out of the output shaft.

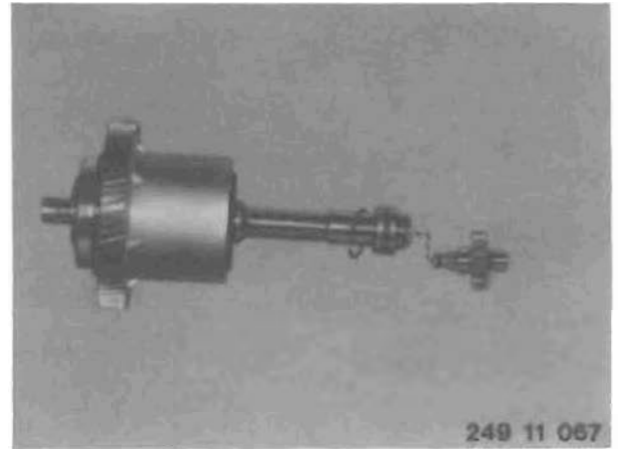

Pull output shaft out of damper (arrow) and remove rubber damper block. Tap shaft out of damper inner section (2) with plastic-faced mallet.

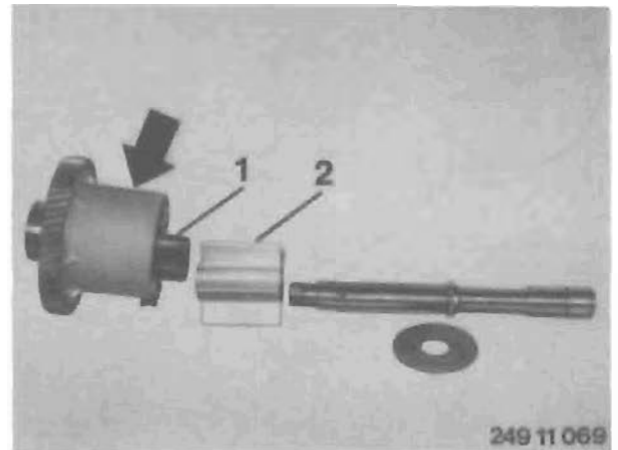

Tensioning gear – stripping down

Pull the output shaft out of the damper until thrust piece BMW 31 1 307 makes contact. Remove circlip with Seeger circlip pliers. Insert BMW puller 00 8 400 into the gear through the opposite aperture and pull off the ball bearing.

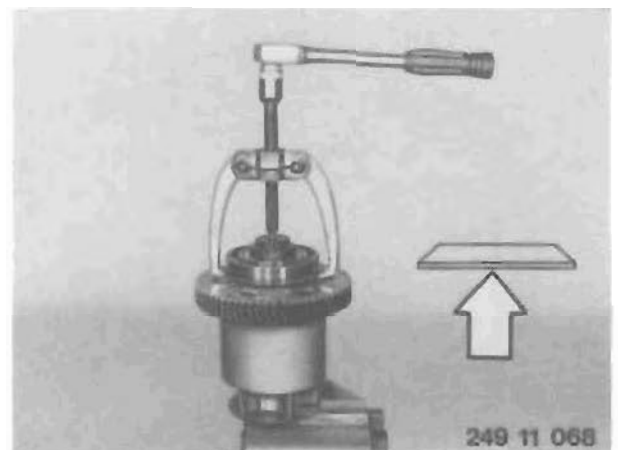

Take off tensioning gear.



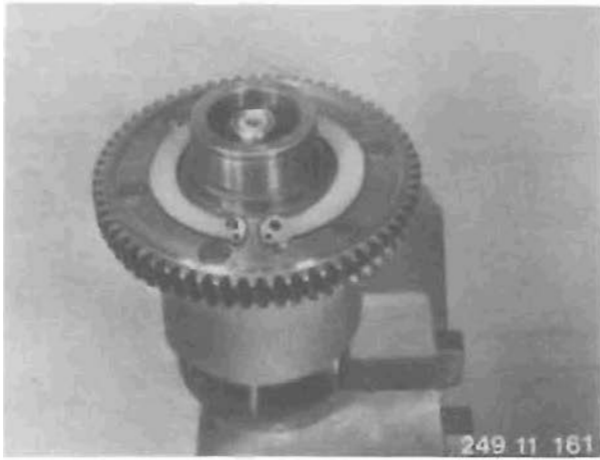

Remove tension spring with Seeger circlip pliers.

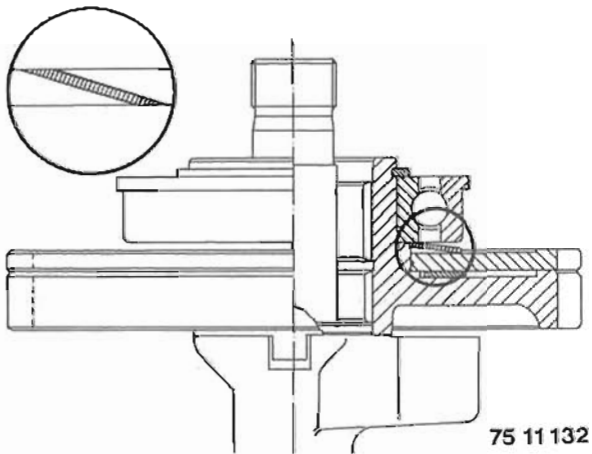

Tensioning gear – assembling

Note:

*Do not re-use the cup spring.
Insert the cup spring.*

Note:

Note direction of installation.

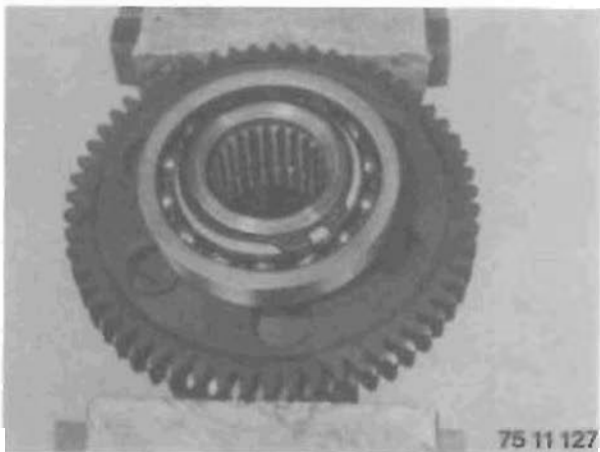

Heat the ball bearing up to app. 80°C.

Bearing version with ring groove and circlip: the ring must be at the bottom;

bearing version with shoulder: shoulder must be at the top.
Press on the bearing until it makes contact.

Insert Seeger ring into the groove using pliers.

Ensure that the Seeger ring is located properly in the groove.

If necessary, tap the bearing down slightly at the inner ring using an arbor, until the Seeger ring snaps into position.

Output shaft

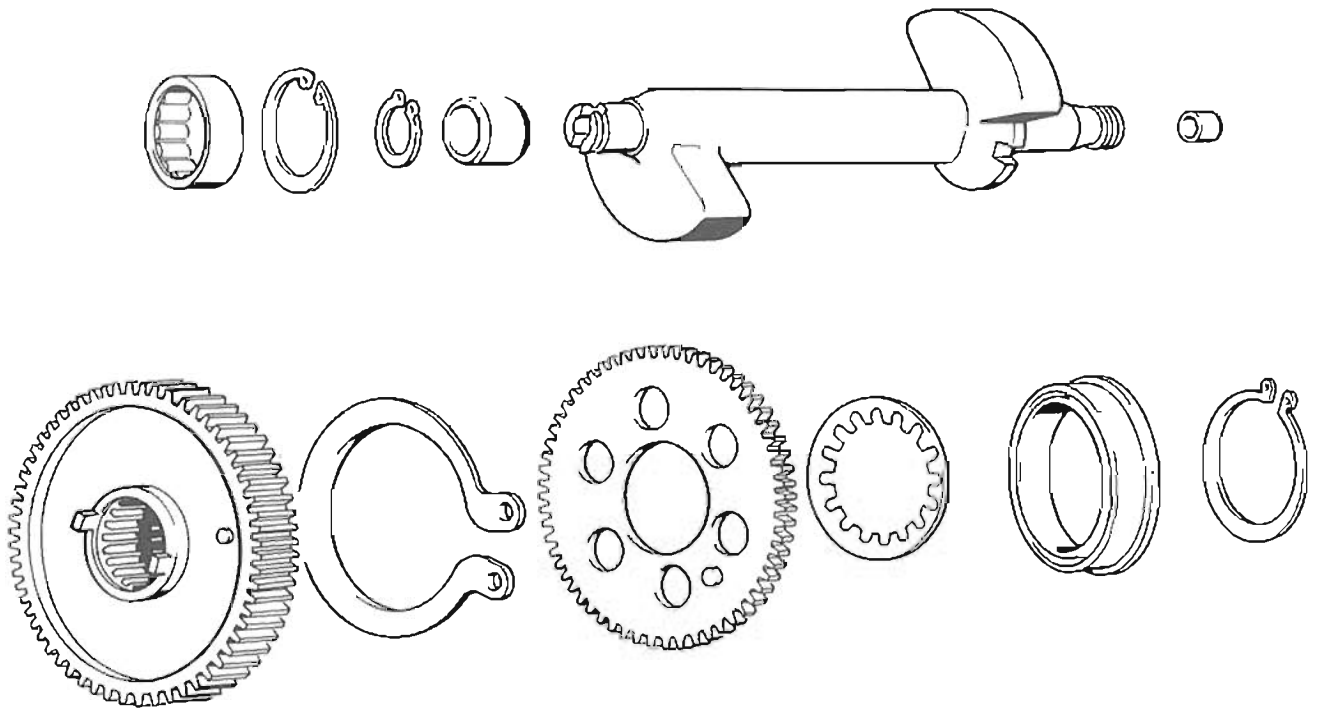

Output shaft – stripping down

Individual parts of output shaft:

- 1 Gear wheel with tensioning gear and ball bearing
- 2 Output shaft
- 3 Circlip
- 4 Needle roller bearing

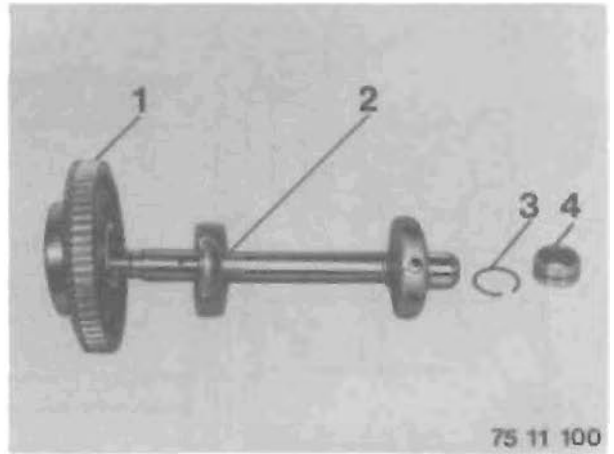

Tensioning gear – stripping down and

Identifying feature: ball bearing secured with Seeger L ring.

Secure the gear wheel/tensioning gear in a vice with aluminium jaws and pull off the circlip with pliers. Pull off the ball bearing with puller BMW 00 8 400 and thrust section BMW 33 1 307 (arrow).

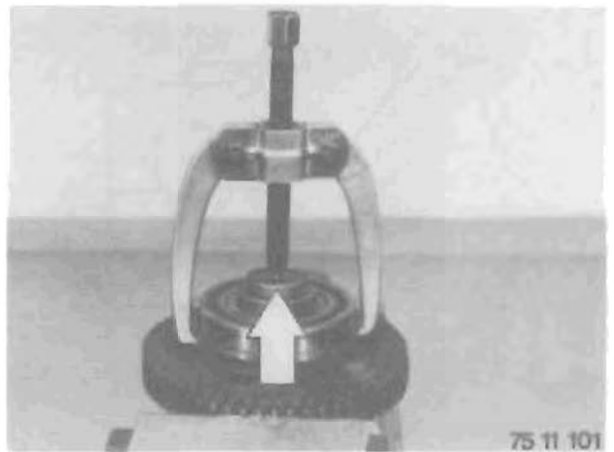

Insert holder 12 4 600 in the tensioning gear. Turn the holder clockwise, pulling the holder up at the same time.

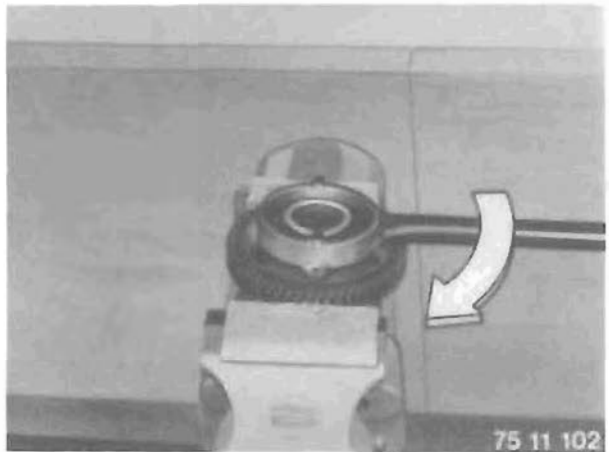

Output shaft – assembling and

Attach the tension spring to the pin (arrow). Attach the tensioning gear pin to the tension spring and turn the gear with holder 12 4 600 clockwise, until the tensioning gear pin engages in the hole in the gear.



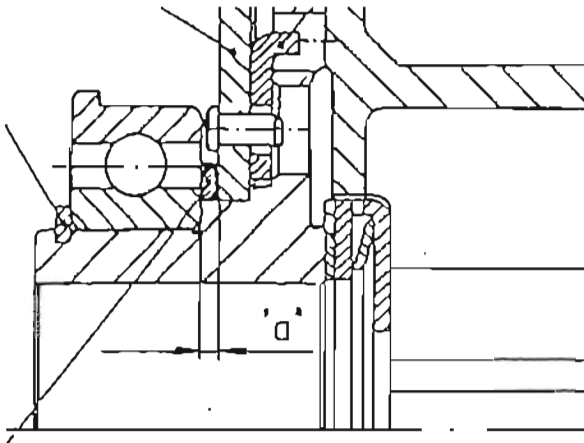

Tensioning gear – shimming

Locate tensioning gear in vice with protective blocks.

Measure dimension "a".

Place the appropriate shim on tensioning gear according to the following table.

Dimension "a"	Shim
1.60-1.75 mm	1.60 mm
1.76-1.90 mm	1.75 mm
1.91-2.05 mm	1.90 mm
2.06-2.15 mm	2.05 mm

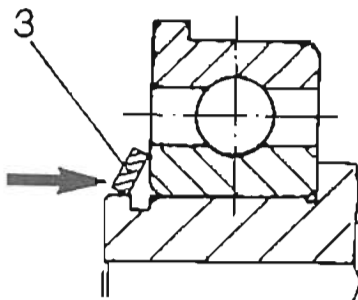

Ball bearing with shoulder – Installing

Heat the ball bearing to app. 80°C and press it against the stop with the shoulder at the top.

Insert the circlip (3) as illustrated.

Note:

In view of axial stress, check that the circlip is perfectly seated in the groove.

Assembling the engine

Install the crankshaft (see page 11–65.0).

Assemble the connecting rods and pistons (see page 11–63.0).

Piston – installing

Apply a generous coat of oil to the piston and piston rings. Turn the piston rings so that the grooves are offset by app. 120°.

Move the relevant crankpin to bottom dead centre.

Note:

Cover the threads of the big end bearing bolt (e.g. with a short piece of rubber hose) to avoid damaging the crankshaft bearings.

Install the piston with BMW strap 11 2 925. The arrow on the piston crown points to the front looking in the direction of travel.

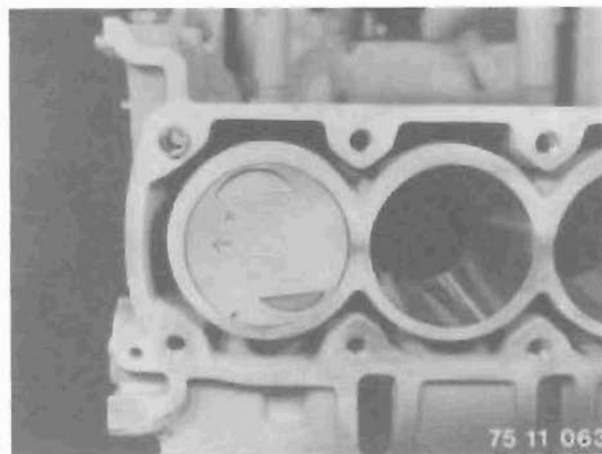
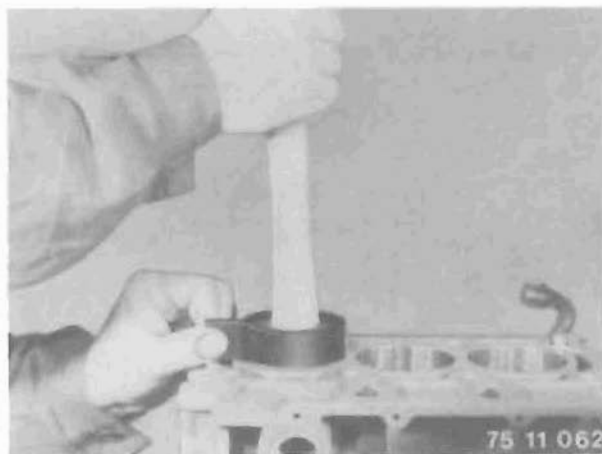

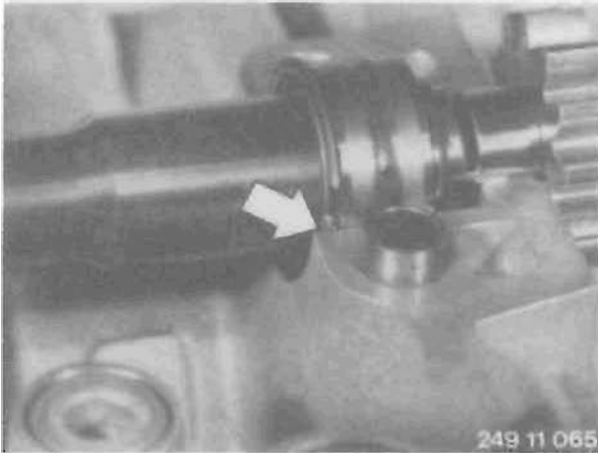

Output shaft – installing

Bearing at oil pump end.

Insert the output shaft with bearing outer ring and circlip so that the gap (arrow) is located exactly at the housing joint faces.

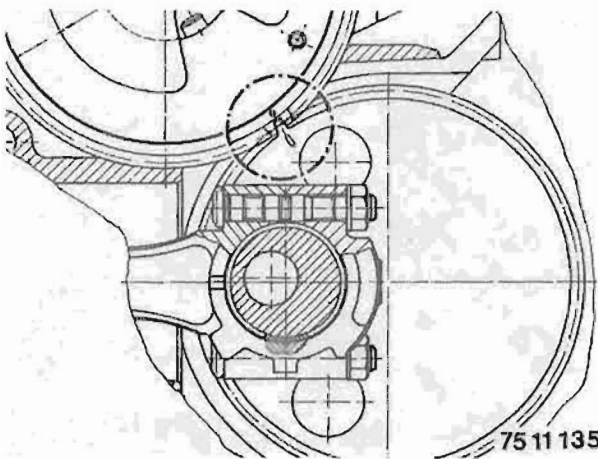

Rotate the crankshaft until the mark on the gear is visible. Insert the output shaft gear so that the marks (arrow) on both gears are aligned.

Note:

The position of the crankshaft relative to the output shaft must not be altered, as this will result in imbalance.

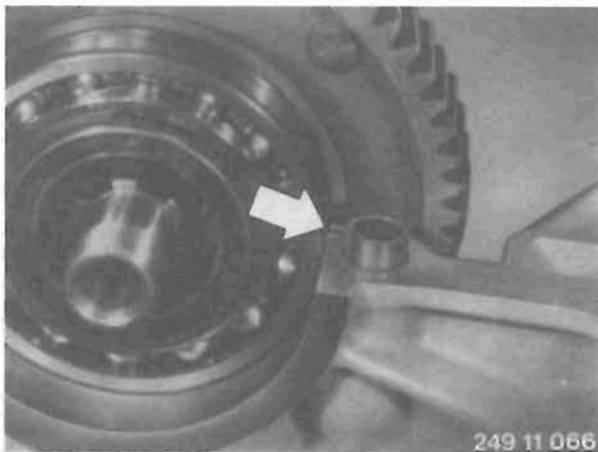

Identifying feature: ball bearing with circlip.

The gap in the circlip (arrow) must be aligned with the surface of the housing.

Note:

Apply a thin coating of Three Bond 11 10 B to the ball bearing seat.

Do not bond the ball bearing with shoulder at its outer race!

Insert retaining screws (arrow) and tighten.

Tightening torque:

Retaining screws

$7 \pm 1 \text{ Nm}$

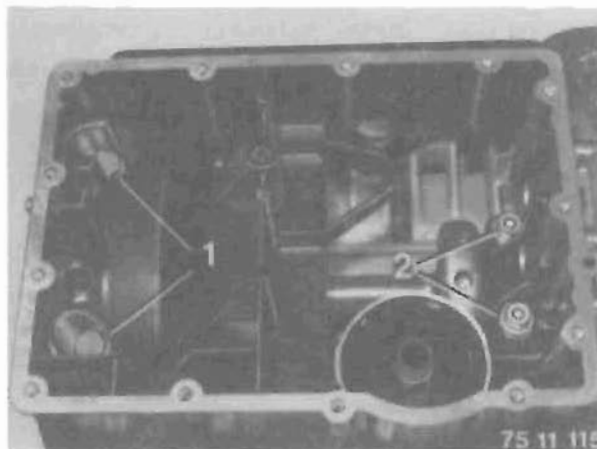

Bottom section of crankcase – installing

The crankcase sealing faces must be free of oil and grease. Apply a thin coat of three Bond 1207 B to the sealing faces.

Insert the O-rings for oil and water passages.

Offer up the bottom section of the crankcase and alternately tighten the retaining screws (1 and 2).

Tightening torque:

Retaining screw (1)

$40 \pm 5 \text{ Nm}$

Retaining screw (2)

$18 \pm 2 \text{ Nm}$

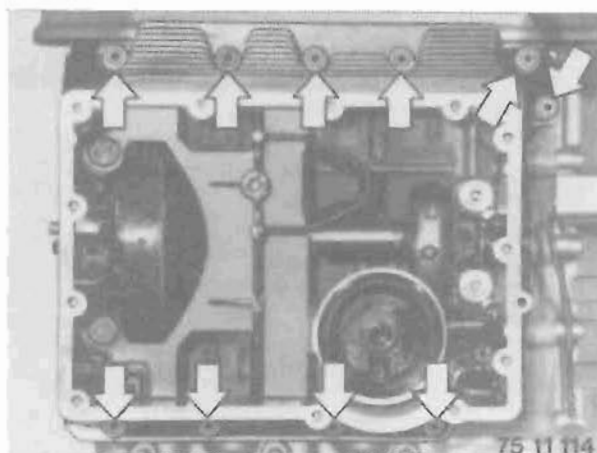

Install the oil strainer. Secure the pipe (arrow) with O-ring in the rubber bushing on the bottom section of the crankcase.

Wet the seal at the oil filter with oil.

Note:

Screw in the oil filter as far as the stop and then tighten further by max. 1/2 turn.

Tightening torque:

Retaining screws

$7 \pm 1 \text{ Nm}$

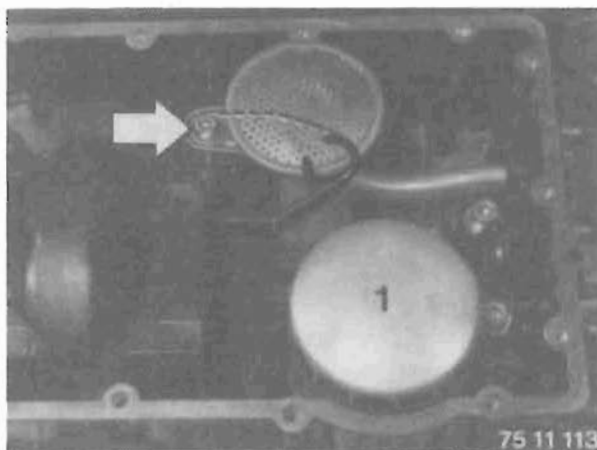

Oil sump – installing

The sealing faces on the crankcase bottom section must be free of oil and grease. Apply a thin coat of Three Bond 1207 B to the sealing faces. Offer up the oil sump.

Uniformly tighten the oil sump retaining screws (arrows). Install the drain screw with a new sealing ring.

Tightening torque:

Retaining screws

$7 \pm 1 \text{ Nm}$

Drain screw

$32 \pm 4 \text{ Nm}$

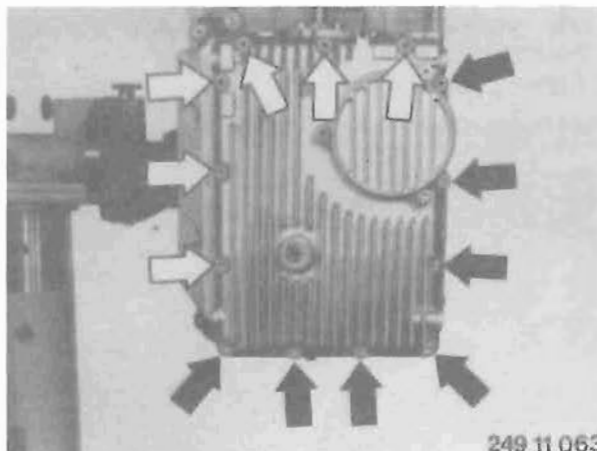

Cylinder head – installing (with engine installed)

Carry out all steps marked * before removing the cylinder head.

- * Camshafts – installing (see page 11 – 79.0)
- * Timing chain – installing (see page 11 – 80.0)
- * Camshaft wheels – installing (see page 11 – 80.0)
- * Slide rails – installing (see page 11 – 80.0)
- * Chain tensioners – installing (see page 11 – 80.0)
- * Valve clearance – checking/adjusting (see page 11 – 81.0)
- * Timing case cover – installing (see page 11 – 82.0)
- * Cover for water pump – installing (see page 11 – 83.0)
- * Cover for Hall-effect transmitter – installing (see page 11 – 84.0)
- * Crankcase cover – installing (see page 11 – 86.0)
- * Spark plugs – installing (see page 11 – 87.0)
- * Cylinder head cover – installing (see page 11 – 87.0)
- * Hose for crankcase breather – securing
- * Hose clip on air collector – tightening
- * Throttle cable – installing (see page 11 – 91.0)
- * Cable connector for increased starting speed/frame wiring harness – connecting up
- * Cable for increased starting speed – installing (see page 11 – 92.0)
- * Hose on thermostat housing – connecting up
- * Coolant – adding (see page 11 – 94.0)
- * Exhaust system – installing (see page 11 – 96.0)
- * Ignition coil cover – installing
- * Frame fixation on driving device (see page 11 – 97.0)

Insert retaining screw (arrow) on frame.

Note:

Do not forget to fit the shim.

Connect up cable connectors for engine wiring harness and:

- * injector nozzles
- * butterfly valve switch.

Push hose on to coolant stub pipe and tighten hose clip (1).

Cylinder head – installing



Turn the engine over to move the piston of cylinder 3 to top dead centre.

Install a new cylinder head gasket.

Note:

Make sure that no holes are covered.

Offer up the cylinder head.

Tighten the retaining bolts according to the diagram and take up slack after 20 minutes.

Tightening torque:

Cylinder head retaining bolts 30 ± 4 Nm
– after 20 minutes 45 ± 5 Nm

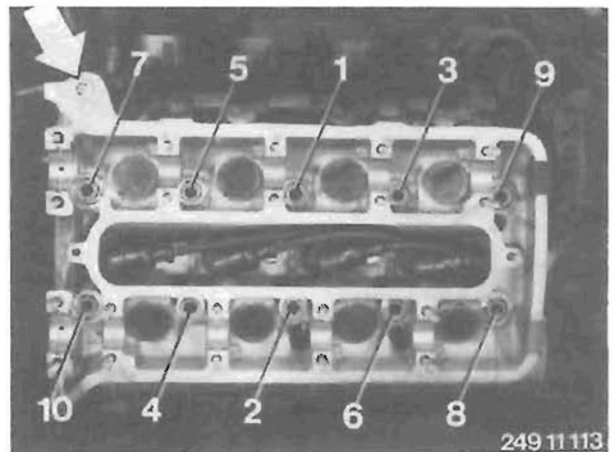
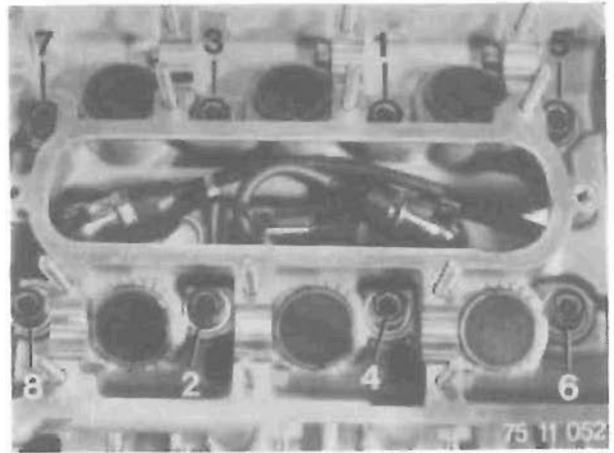

Camshafts – installing



Insert the camshafts so that the cams of cylinder 3 face inwards.

Offer up the bearing mounts.

Note:

The numbers on the cylinder head must agree with the bearing mount numbers.

Tighten the remaining bearing mounts uniformly from the inside to the outside.

Tightening torque:

Bearing mount nuts 9 ± 1 Nm

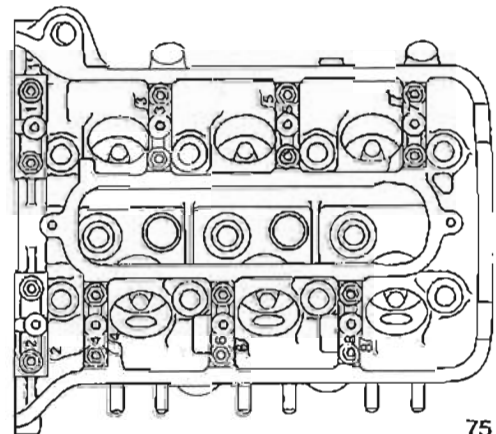

Install camshafts in such a way that stresses generated when the bearings are tightened are kept to a minimum (i.e. no cam should be perpendicular to the a bucket-type tappet). Assemble first the inner bearing blocks (arrows), then the outer ones.

Tightening torque:

Camshaft bearing block 9 ± 1 Nm

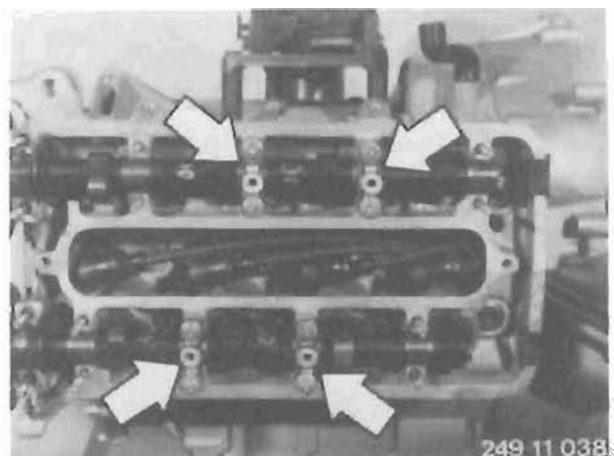

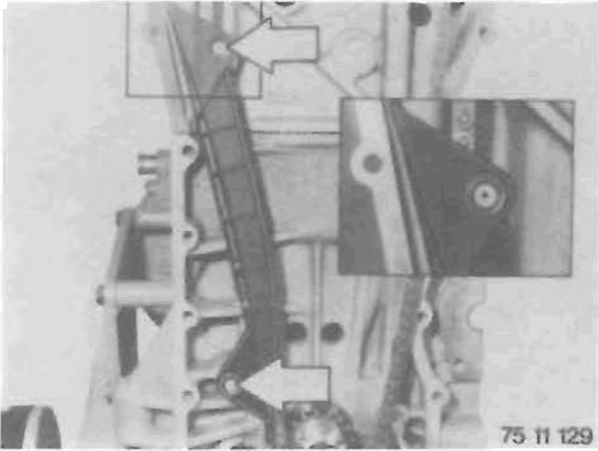

Timing chain – installing



Bring cylinder 3 to top dead centre.
The pin on the crankshaft sprocket must be aligned with the housing rib.
Install the chain guide with the timing chain. Push the washers and circlips on the pin.



Bring cylinder 1 to top dead centre.
Install the chain guide rail, assemble the washers and circlips and fit the timing chain.

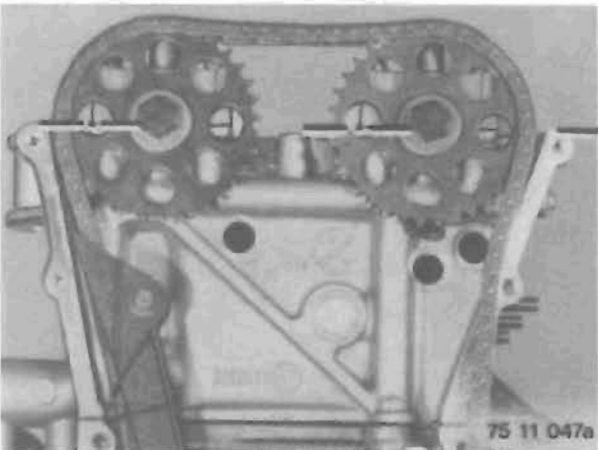

Camshaft gears – installing

Loosely secure the camshaft gears to the camshafts with the retaining screws.
Rotate the camshafts until marks on the camshaft gears (see illustration) are aligned with the joint between the bearing cover and cylinder head.
Place the timing chain over the sprockets (keep the tension side taut).
Secure the camshaft gears to the camshaft.
Hold the hexagon on the camshaft to prevent it from turning.
Tighten the retaining screws.

Tightening torque:

Camshaft gear retaining screws

$54 \pm 6 \text{ Nm}$

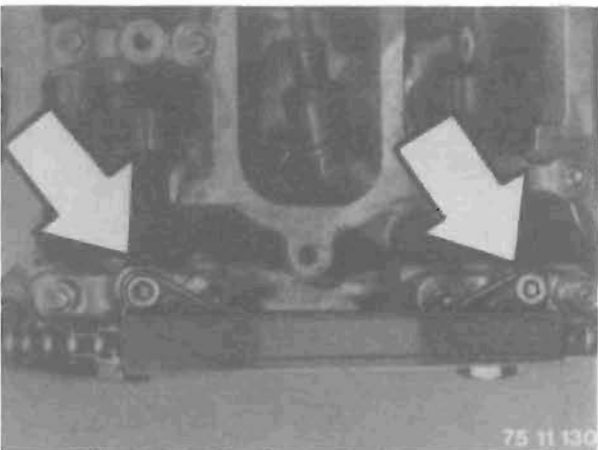

Slide rail – installing

Insert slide rail and secure with retaining screws.
Use BMW Torx insert 00 2 600 for Torx screws.

Tightening torque:

Retaining screws

$9 \pm 1 \text{ Nm}$

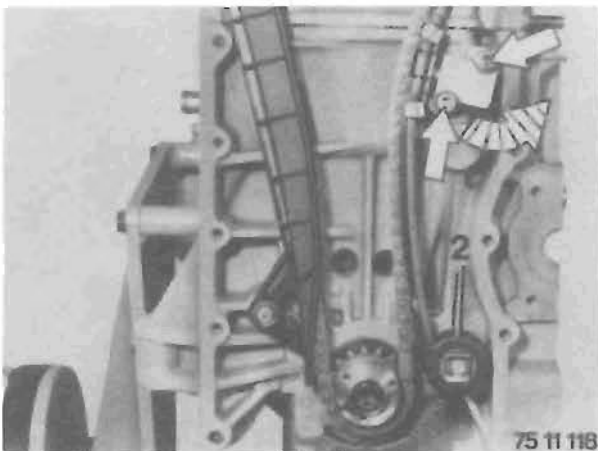

Chain tensioner – installing

Place the tensioner rail on the pin and secure it with a washer and circlip.

Install the chain tensioner (noting the lug on ).

Tighten the retaining screw.

Rotate the engine fully one cycle and check the position of the camshaft gears in relation to each other and also in relation to the crankshaft pinion.

Tightening torque:

Chain tensioner retaining screw

$9 \pm 1 \text{ Nm}$

Valve clearance – adjusting

Turn the piston of the cylinder to be measured to “overlap TDC” = “ignition TDC”.

The camshaft cams are opposed on this cylinder, pointing slightly upwards.

Measure clearance with a feeler gauge.

Valve clearance measured at max. 35°C engine temperature

Inlet 0.15-0.20 mm

Exhaust 0.25-0.30 mm

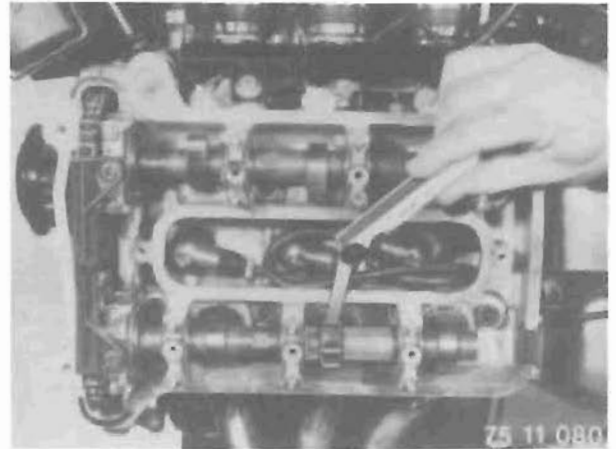

To renew the shim plates, turn the tappets until the groove faces inwards at app. 45° (arrows).

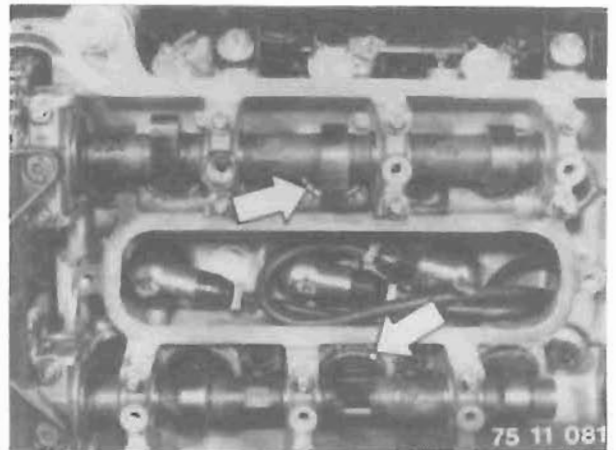

Press the tappet down with BMW holding-down tool 11 1 720.

Note:

Offer up and press the holding-down tool outwards in such a way that it presses on the shim plate (and does not apply one-sided pressure to the tappet, thus avoiding tilt).

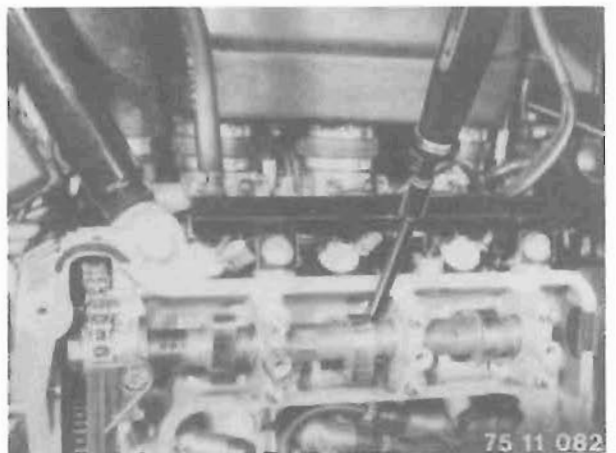

Place BMW spacer 4 1 722 on the edge of the tappet (the shim plate can be moved) and remove the holding-down tool.



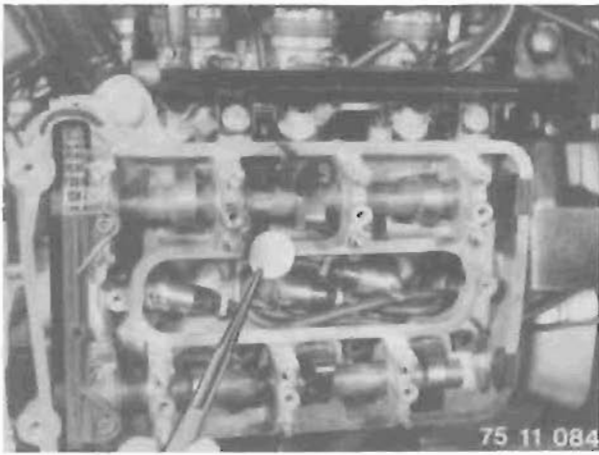

Insert BMW special pliers 11 1 730 through the groove in the tappet and under the shim plate and take out the clip to the side.

Important:

On each occasion after adjusting valve clearance, the throttle butterfly stub pipe assembly must be synchronized (see page 13-07.0).

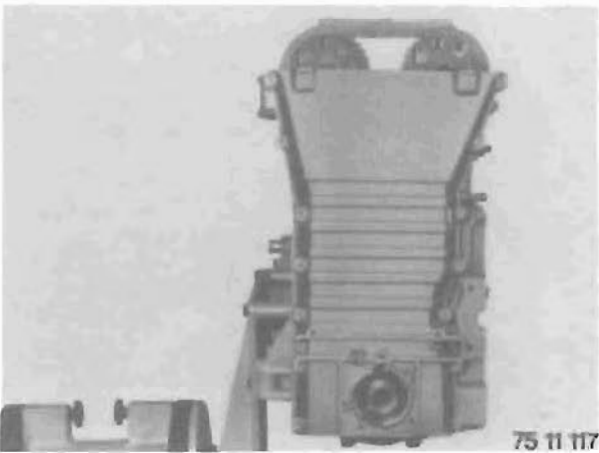

Timing chain cover – installing

The sealing faces must be free of oil and and grease. Apply a thin coat of Three Bond 1207 B to the sealing faces.

Offer up the timing chain cover and tighten the retaining screws.

Note:

Carefully push the timing chain cover over the rotor flange.

Tightening torque:

Timing chain cover retaining screws 7 ± 1 Nm

Combined water/oil pump – installing

Insert the O-ring for the water passage in the bottom section of the crankcase.
Insert the oil pump impeller with a lightly oiled O-ring in the groove in the output shaft.

The joint face must be free of oil and grease. Apply a thin coat of Three bond 1207 B to the joint face.

Offer up the pump housing and tighten the retaining screws, turning the crankshaft tight at the same time (to centre the oil pump gears).

Tightening torque:

Pump housing retaining screws 7 ± 1 Nm

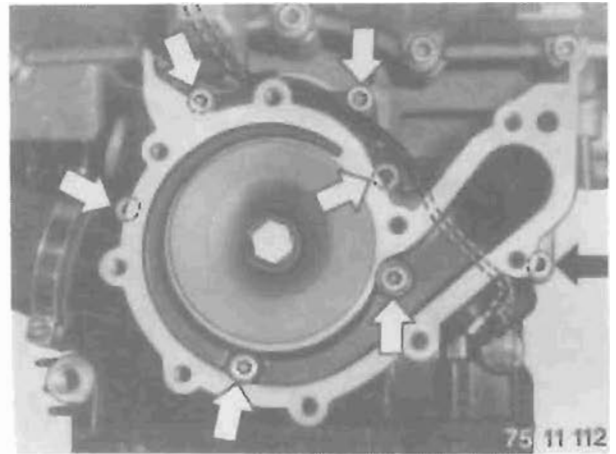

Cover for water pump – installing

Install the line for the oil pressure switch, pass it through the opening in the pump housing and connect it to the switch.

The joint face must be free of oil and grease. Apply a thin coat of Three bond 1207 B to the joint face and tighten the retaining screws.

Tightening torque:

Oil pressure switch retaining screws 7 ± 1 Nm

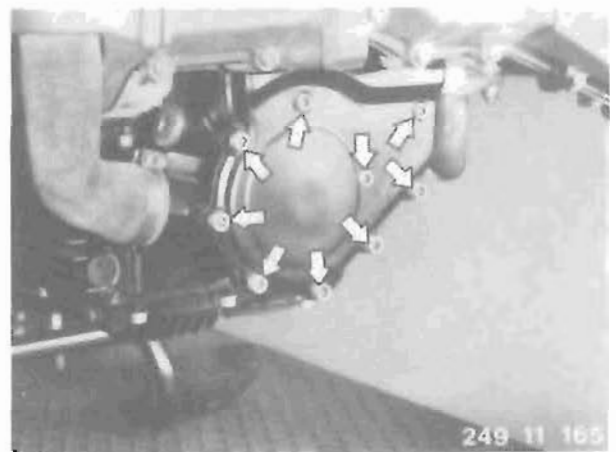

Rotor blade – installing

Insert the shim for the top dead centre and gate rotor and tighten the retaining screws (arrows).

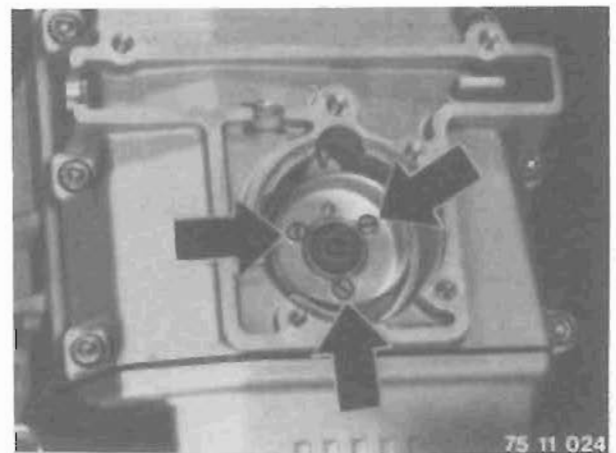

Hall-effect transmitter – installing

Install the Hall-effect transmitter and insert the retaining screws.

Note:

Note the shim washer.

Install the line. Secure the oil pressure switch line with the clip (1).

Adjust the ignition timing statically (see page 12 – 10.0).

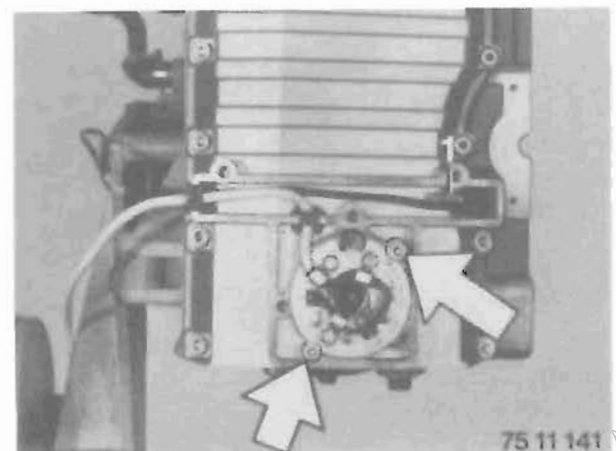

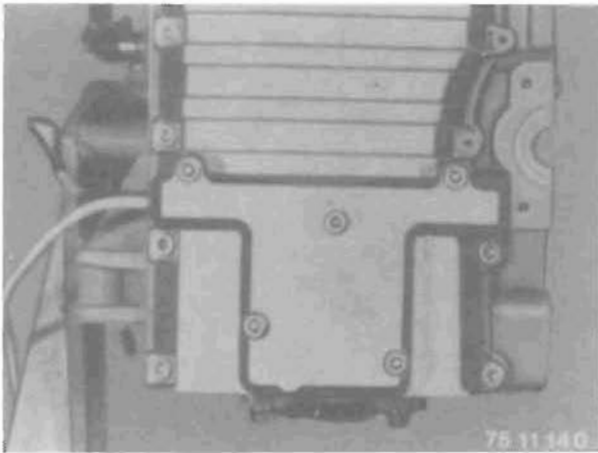

Hall-effect transmitter cover – installing

Offer up the Hall-effect transmitter cover, with seal, and tighten the retaining screws.

Tightening torque:

Cover retaining screws

$6 \pm 1 \text{ Nm}$

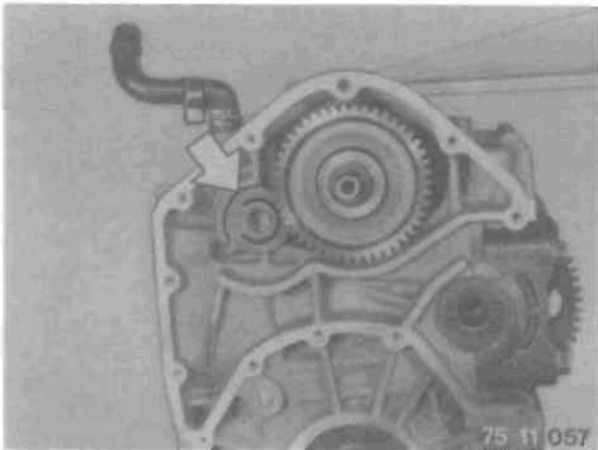

Freewheel and auxiliary shaft – installing

Insert the spring.

Note the correct installed position: the large diameter is in contact with the freewheel gear.

Install the auxiliary shaft with freewheel.

Important:

When installing a new part, always clean off the corrosion protection material and apply a generous coat of engine oil.

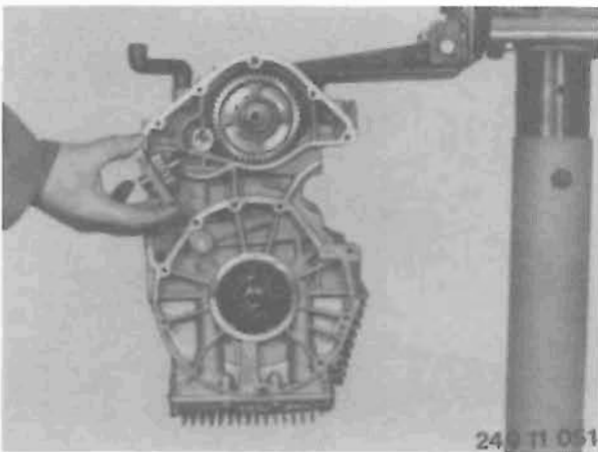

Insert the countershaft.

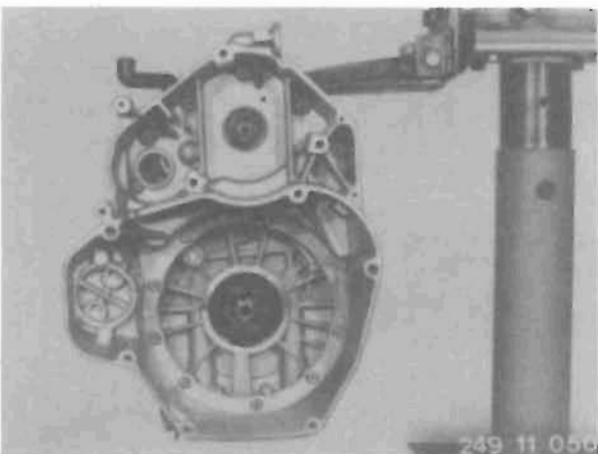

Intermediate flange – installing

Note:

Ensure that all adapter sleeves are present.

The joint face must be free of oil and grease. Apply a thin coat of Three Bond 1207 B to the joint face. Offer up the intermediate flange and tighten the retaining screws with Torx insert BMW No. 00 2 600.

Note:

Remember to install the filler.

Tightening torque:

Intermediate flange retaining screws

$9 \pm 1 \text{ Nm}$

Output shaft sealing ring – installing

Drive in the shaft sealing ring with BMW arbor 11 1 630 and handle 00 5 500.

Note:

Oil the sealing ring and push it over the guide piece first.

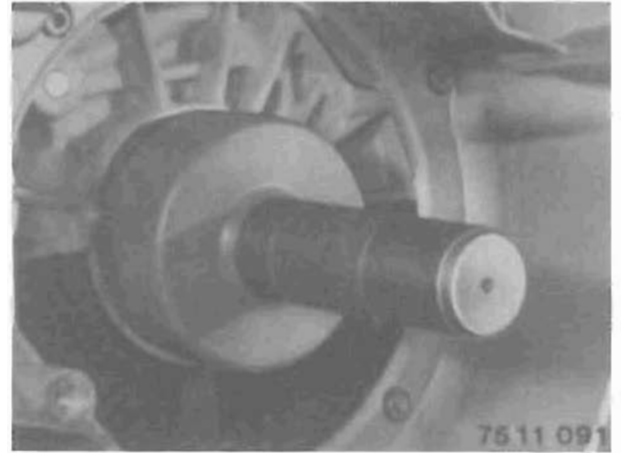

Clutch housing – installing



Install the clutch housing in the position illustrated with BMW holder 11 2 800.



Before installing the clutch housing, fit the stop plate between output shaft and intermediate flange. Install the clutch housing with BMW holder 11 2 800.

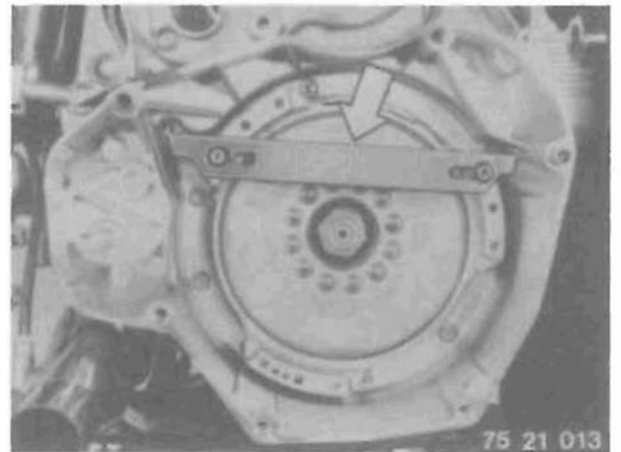

Install the new O-ring and thrust washer (arrow) and secure the hex nut.

Tightening torque:



Hex nut 140 + 5 Nm



Hex nut 140 ± 5 Nm

Tighten, loosen and retighten to 100 ⁺¹⁴/₋₁₀ Nm



Insert the wire ring/diaphragm spring in the clutch flange. Insert the pressure plate, clutch plate and housing cover in such a way that the colour markings are offset by 120°. Centre the clutch plate with BMW centring tool 21 2 670.

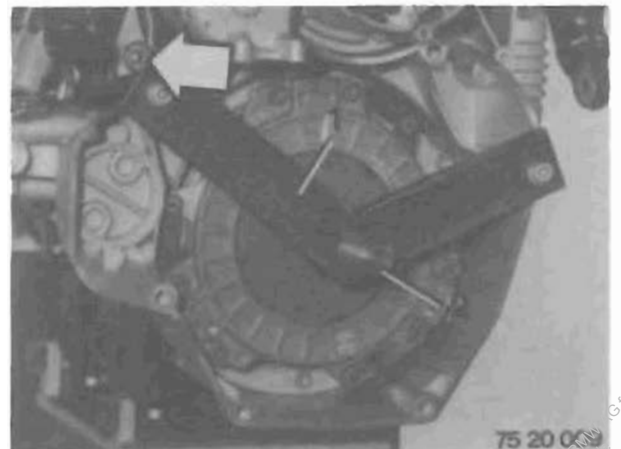

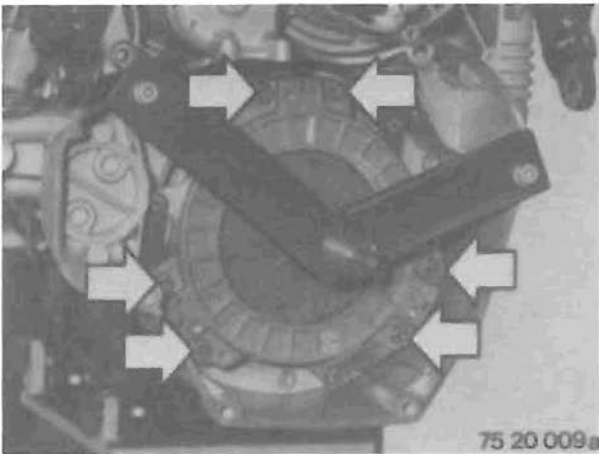

Tighten retaining screws for housing cover.

Tightening torque:

Housing cover retaining screws $19 \pm 2 \text{ Nm}$

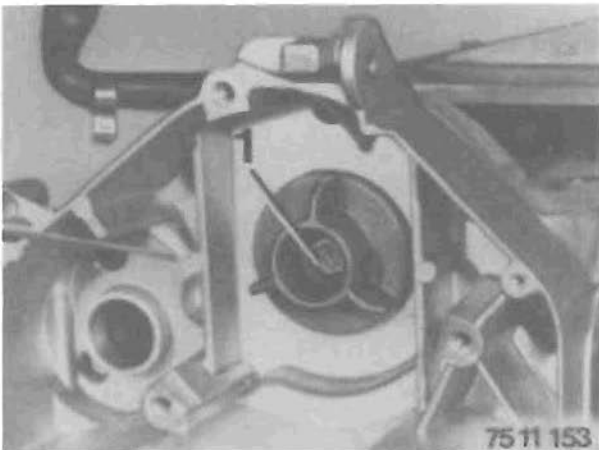

Driver – installing

Clean Loctite from the thread in the intermediate shaft and the retaining screw.

Push the driver on to the auxiliary shaft.

Tighten the retaining screw with Loctite 273 FL.

Tightening torque:

Driver retaining screw $33 \pm 4 \text{ Nm}$

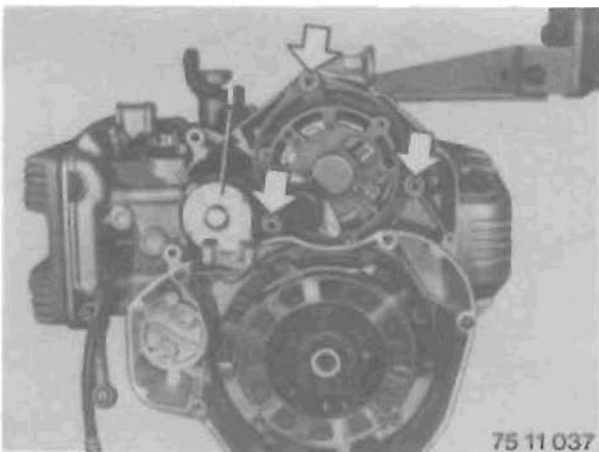

Alternator – installing

Install the alternator with the rubber damper and tighten the retaining screws (arrows).

Tightening torque:

Alternator retaining screws $22 \pm 3 \text{ Nm}$

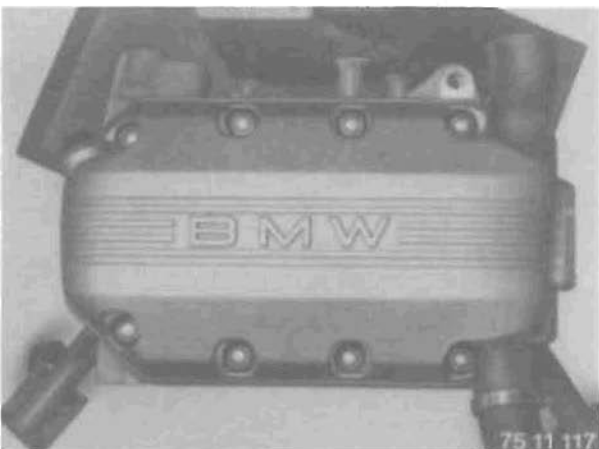

Crankcase cover – Installing

Turn the engine round (until crankshaft on top).

The joint faces between the crankcase, intermediate flange and crankcase cover and the crankcase, timing case cover and crankcase cover must be free of oil and grease. Apply a thin coat of Three Bond 1207 B to the joint face.

Offer up the crankcase cover and tighten the retaining screws uniformly working from the inside to the outside.

Push the coolant hose on to the water pump.

Secure the hose clip.

Tightening torque:

Crankcase cover retaining screws $8 \pm 1 \text{ Nm}$

(If necessary, turn the engine upwards and to the front.)

Spark plugs – installing

Turn the engine round (camshafts at top).
Tighten the spark plugs with BMW spark plug wrench 12 3 500.

Tightening torque:
Spark plugs 20 ± 2 Nm

Attach the spark plug caps to the spark plugs. Install the spark plug leads correctly.

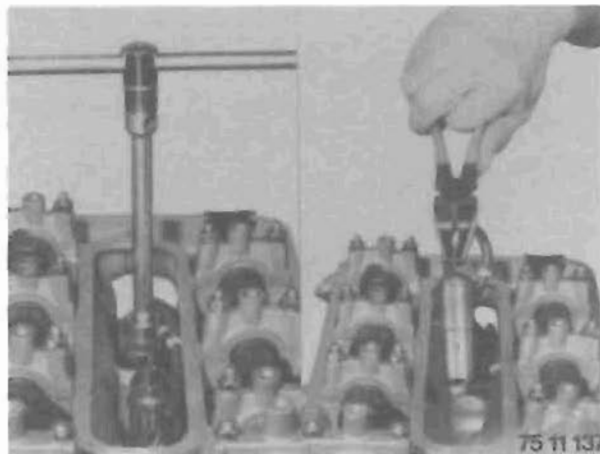

Cylinder head cover – installing

Apply a thin coat of Three Bond 1207 B to the front edge of the housing (cylinder head/timing case cover/cylinder head cover).

Offer up the cylinder head cover and tighten the retaining screws working from the inside to the outside.

Note:
Do not forget the contact springs.

Tightening torque:
Cylinder head cover retaining screws 8 ± 1 Nm

Turn the engine round (installed position).

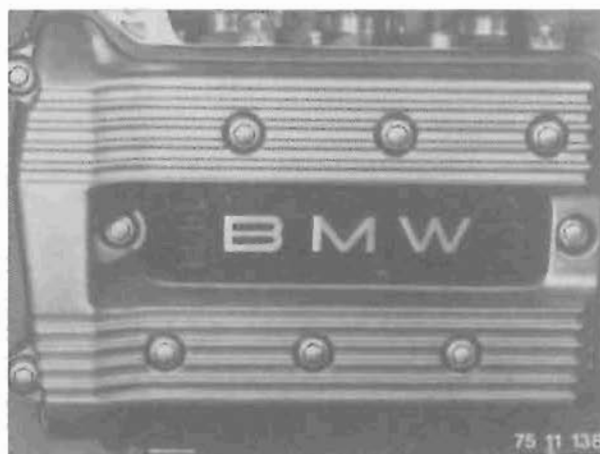

Place the coolant stub (arrow), with O-ring, on the cylinder head and tighten the retaining screws.

Install the intake stub and tighten the retaining screws uniformly.

Tightening torque:
Retaining screws coolant stub 7 ± 1 Nm
intake stub 7 ± 1 Nm

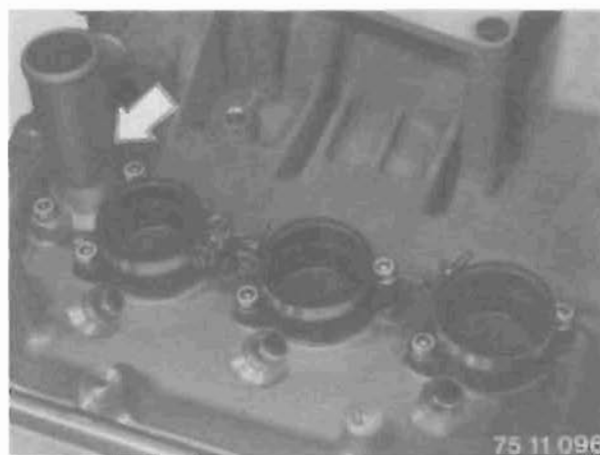

Throttle butterfly stub pipe assembly – installing

Attach the throttle butterfly stub pipe assembly complete with air collector and injector rail.
Tighten the hose clips.

Note:
Turn the hose clips for cylinder 3 or 4 inwards by app. 35°. The throttle butterfly lever must be able to move freely.

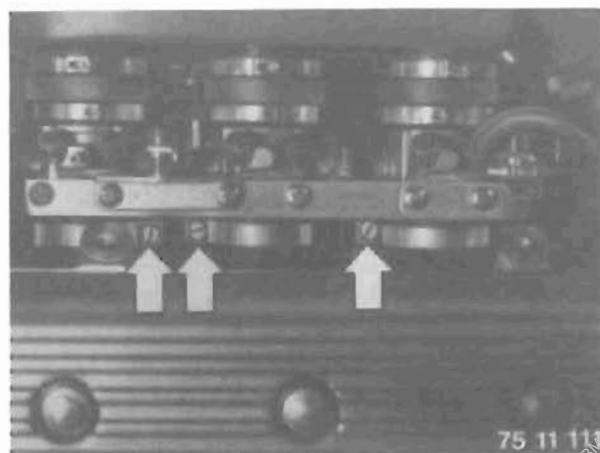

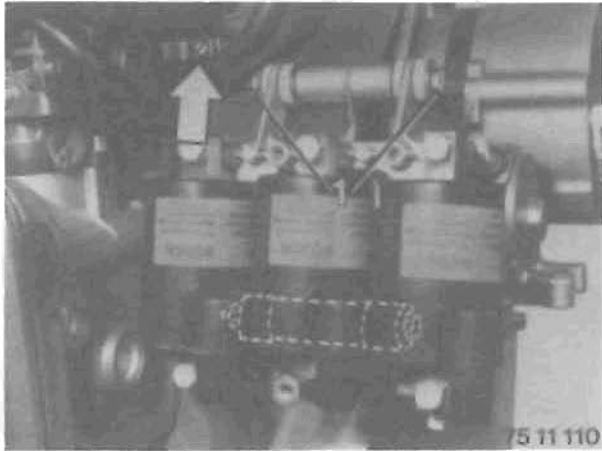

Ignition coils – installing

Secure the ignition coil holder to the intermediate flange, first at the bottom, then at the top.
Connect the ignition leads to the ignition coils, noting the numbers.



Ignition coil 3 is at the rear.



Note instructions on ignition coils.

Connect the hose (crankcase breather) to the crankcase with hose clip (arrow).

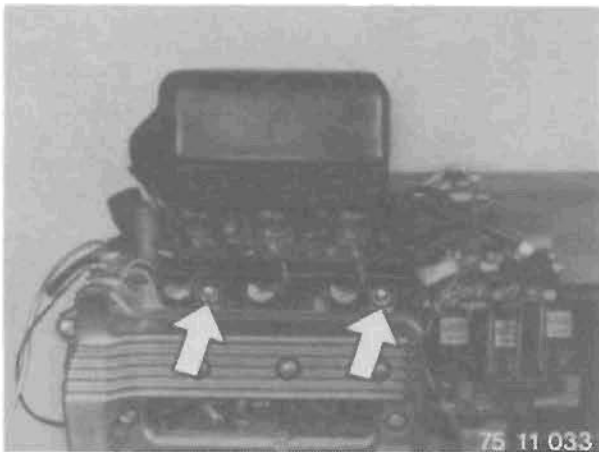

Injectors – installing

Install the injector rail with injectors.
Moisten the injector O-rings and press them in the nozzle passage. Be careful not to damage the O-rings.
Tighten the retaining screws.

Tightening torque:

Injector rail retaining screws

$7 \pm 1 \text{ Nm}$

Driveline – assembling

Position the assembly stand with engine at the hoist.
Raise the hoist until the engine lifter can be attached to the oil sump.
Slacken off the engine mount on the engine.

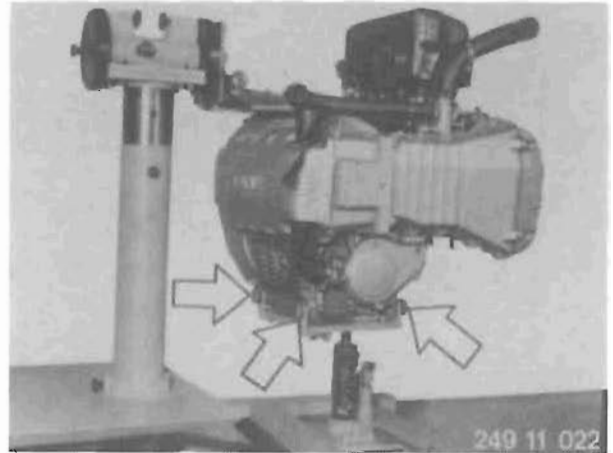

Connect the complete driveline to the engine.

Note:

Coat the drive splines with Staburags.

It is vital that the engine and gearbox are at the same height (to avoid damaging the clutch thrust rod).

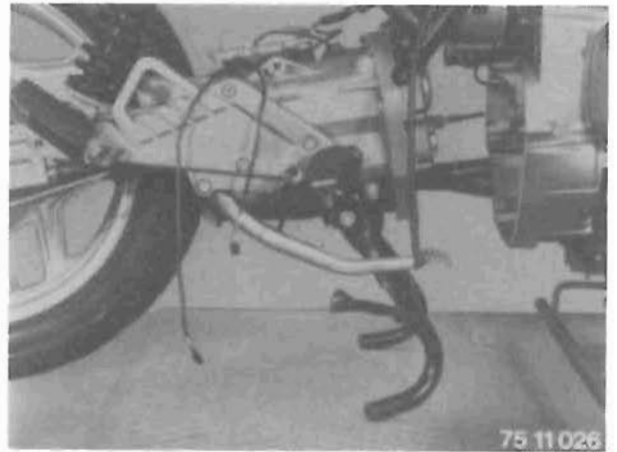

Screw in the gearbox and engine retaining bolts.

Install and secure the starter motor.

Tightening torque:

Starter on gearbox

$7 \pm 1 \text{ Nm}$

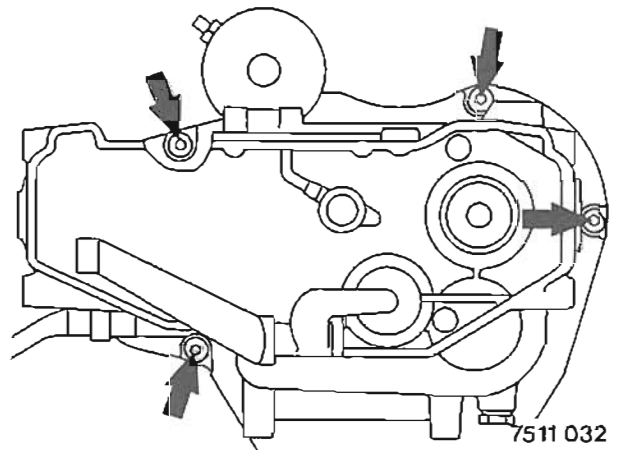

Mounting for centre stand – removing and installing

Slacken off the retaining screws (arrow) for the mounting on the underside of the gearbox and take off the mounting.

Insert and tighten the two lower gearbox and engine retaining bolts.

Insert and tighten the **microencapsulated** screws in the underside of the gearbox to secure the mounting.

Tightening torque:

Gearbox to engine

$16 \pm 2 \text{ Nm}$

Mounting to gearbox

$41 \pm 5 \text{ Nm}$





Air cleaner housing – installing

Attach the bottom section of the air cleaner housing to the engine.

Offer up the air cleaner element.

Tightening torque:

Bottom section of air cleaner housing to crankcase

$21 \pm 2 \text{ Nm}$



Secure the top section of the air cleaner housing to the bottom section with the clips (arrow).

Tighten the hose clip (1) on the air collector.

Make the plug connections for the throttle butterfly switch, injector nozzles and temperature sensor.

Secure the lead to the injector rail (circle) with adhesive tape

Locating frame on driveline

Remove the frame support, BMW No. 46 5 620, from the rear frame tube.

Place the frame down on the engine and drive assembly.

Raise/lower the drive assembly with the engine lifter until the frame bolts can be screwed in by hand.

Secure the spring strut to the final drive.

Tightening torque:

Spring strut on final drive

$51 \pm 6 \text{ Nm}$

Throttle cable – installing

Attach the cable to the reaction bearing.

Turn the segment inwards in the direction of the arrow and attach the nipple.

Important:

Do not bend the throttle cable, as any kinks will be subject to greater wear.

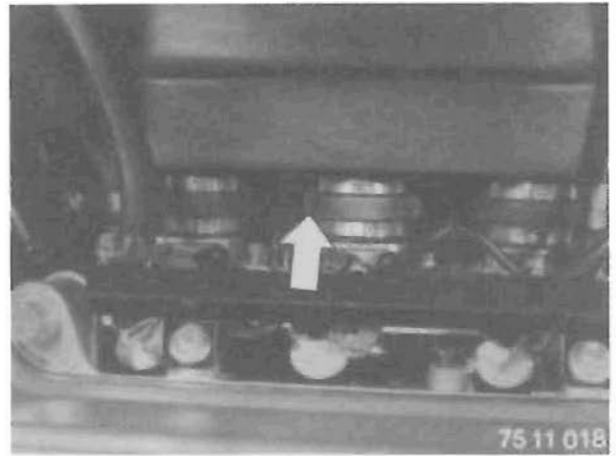

Clutch cable – installing

Pull the cable through the opening at the gearbox.

Attach the nipple to the clutch release lever (arrow).

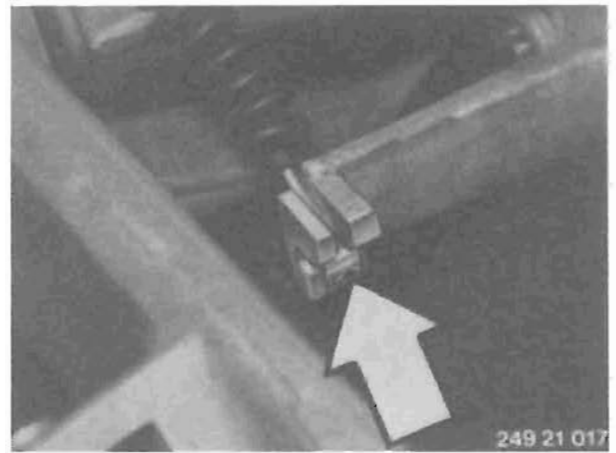

Engine wiring harness – installing

Install the engine wiring harness on the frame.

Secure the earth cable (arrow) to the frame.

Connect the engine wiring harness to the frame wiring harness.

Connect the plug for the increased starting speed to the frame wiring harness.

Secure the cables with tape.

Avoid creating kinks or points which could wear.

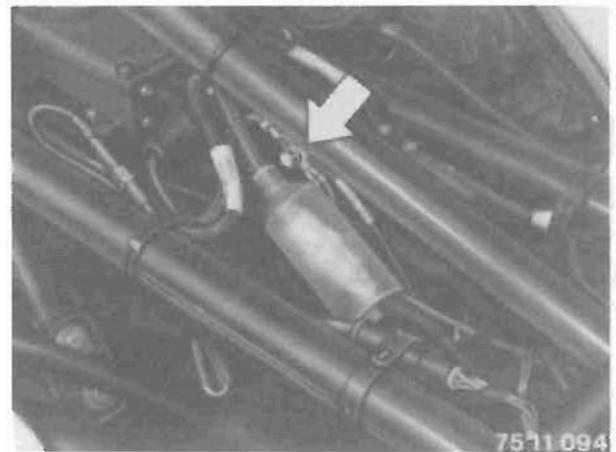

Ignition coils – connecting up



Secure the two-pin plug and the earth lead (2) to ignition coil 3.

Ignition coil 1 blue/black

Ignition coil 2 red/black

Ignition coil 3 green/black



Secure lines for terminals 1 and 15. Note instructions on the ignition coils.

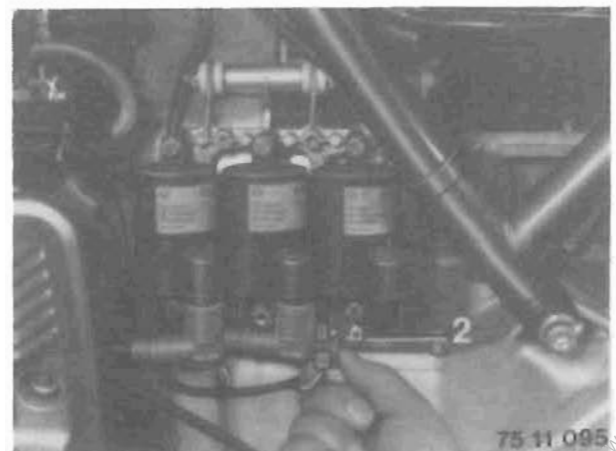

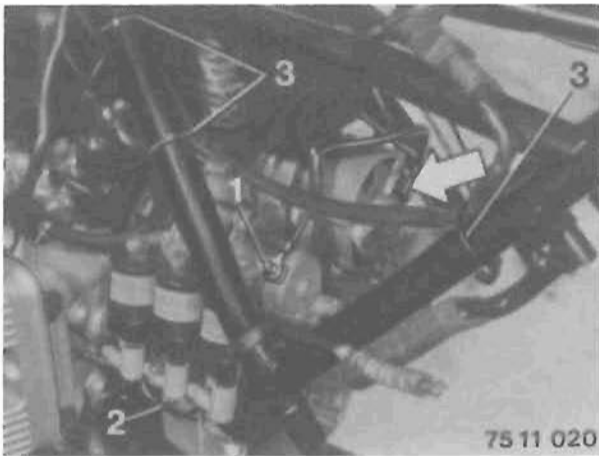

Secure cable (1) to the starter motor.
Connect the plug (arrow) to the alternator.
Secure the cables with tape (3).

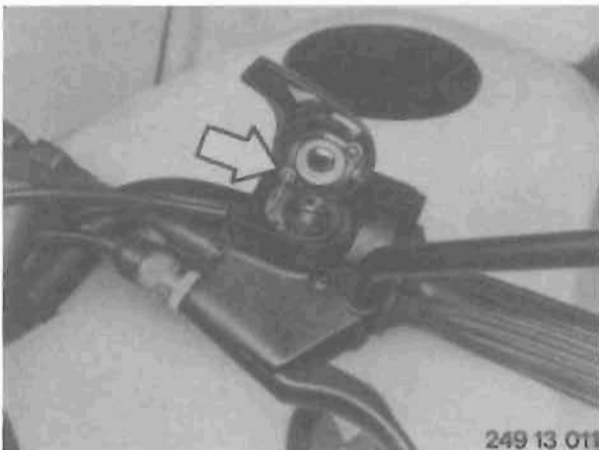

Cable for increased starting speed – installing

Attach the nipple (arrow) to the increased engine speed lever.
Tighten the lever with retaining bolt.
Press on the cover.

Note:
Note position of cable at control head.
Cables are installed above the electric wiring.

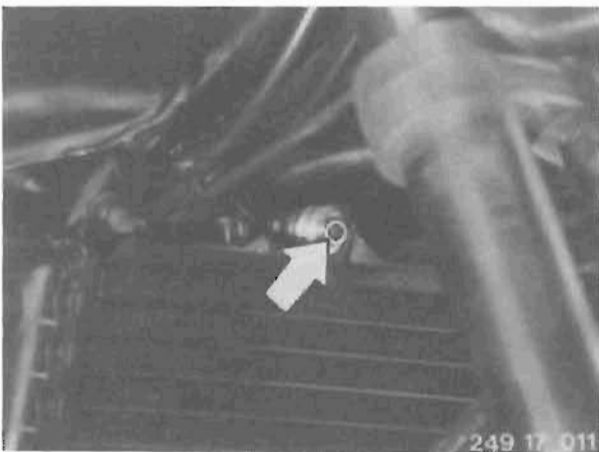

Radiator – installing

Attach the radiator, with the plates at the bottom, to the rubber bushings on the frame.
Make the plug connection for the fan.
Push the radiator in at the top and secure to the frame with the retaining bolt (arrow).

Tightening torque:
Radiator retaining bolt $8 \pm 1 \text{ Nm}$

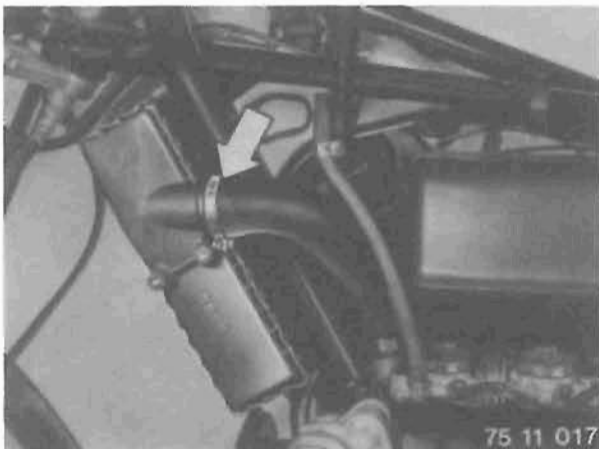

Connect the coolant hose to the left of the radiator and tighten the hose clip (arrow).

Note:
Note the correct installed position for the hose clip.

Attach the coolant hoses to the thermostat housing and tighten the hose clips (arrows).

Note:

Note the correct installed position for the hose clips.



Connect the coolant hose to the top right of the radiator and tighten the hose clip (1).
connect the air intake line, first to the intake stub, then to the bottom section of the air cleaner housing.

Note:

Moisten the rubber seal before installing.



Connections on frame wiring harness

Connect the plugs for the Hall-effect transmitter (1) and the oil pressure switch (2) to the frame wiring harness.

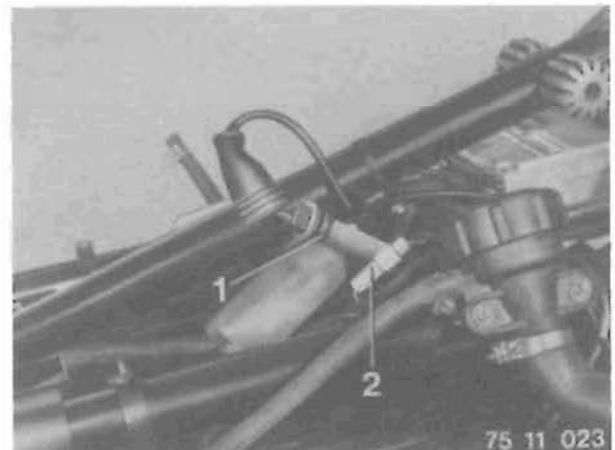

Connect the plugs for the inductive sensor, brake light switch and gearbox switch to the frame wiring harness.
Secure the cables with tape (arrow).





Take off the coolant reservoir from the frame and place it on the battery baseplate.
Install the alternator cover.
Tighten the retaining screws at the intermediate flange.

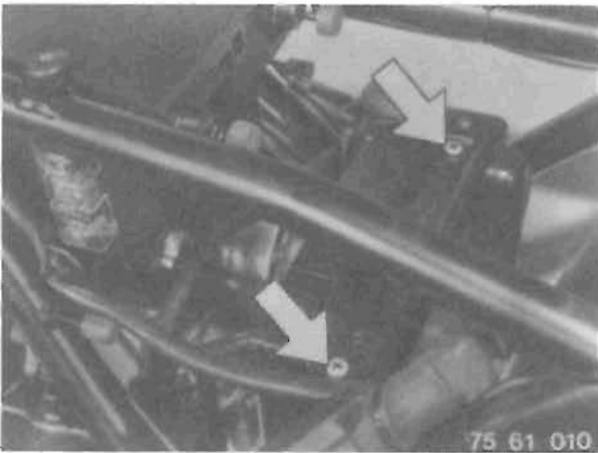

Battery – installing

Secure the positive lead to the positive terminal post.
Attach the negative lead to the gearbox.
Connect the breather hose to the battery.
Carefully tighten the retaining screws (arrows) for the battery holder.

Note:

At the same time, the coolant reservoir is clamped firmly in place.



Coolant – adding

Add coolant at the filler pipe.

Note:

Use only recommended grades (see Specifications, page 17–03.0).

Capacity:



2.5 l

+ 0.4 l in reservoir.



2.8 l

Normal concentration 40 : 60 ... – 28°C

(40% antifreeze : 60% water)

For Scandinavian countries: 50 : 50

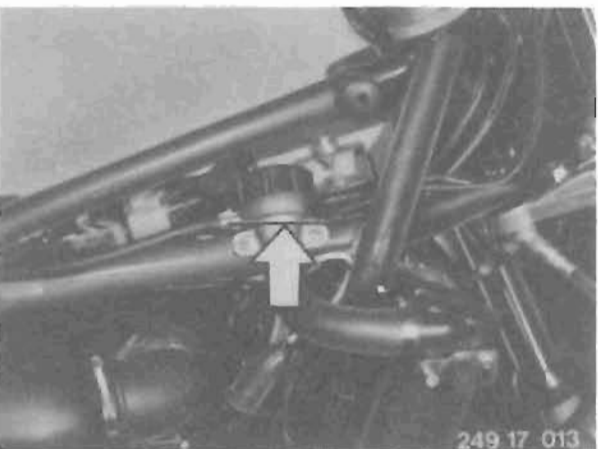

Add coolant at the filler pipe up to the bottom edge of the overflow (arrow).

Note:

To bleed the cooling system, turn the engine over with the starter motor, at the same time "kneading" the coolant hose between the water pump and thermostat housing.
Top up with coolant if necessary.

The reservoir must be filled to between the "MIN" and "MAX" marks.

Note:

Never fill to beyond the "MAX" mark.

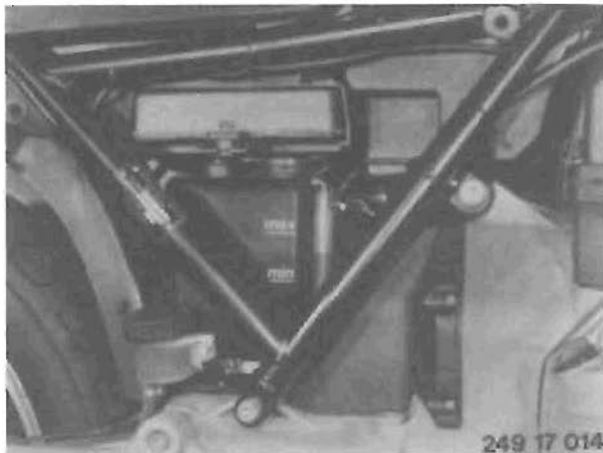

Install the storage tray with injection control unit and attach the multi-pin plug with lug at the front, then engage it in the retaining clip at the rear. Press on the cover.

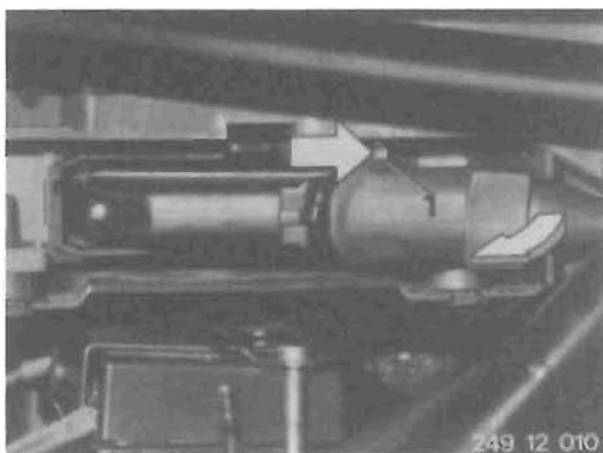

Rear mudguard and licence plate holder – installing

Install the rear mudguard and insert the hoop with threaded pins through the holes in the mudguard from the bottom.

Screw on the nuts (arrows).



Clamp the licence plate holder between the mudguard and retaining hoop.

Tighten the retaining screws (arrows).

Now tighten the mudguard retaining nuts (see illustration 75 23 010, top).

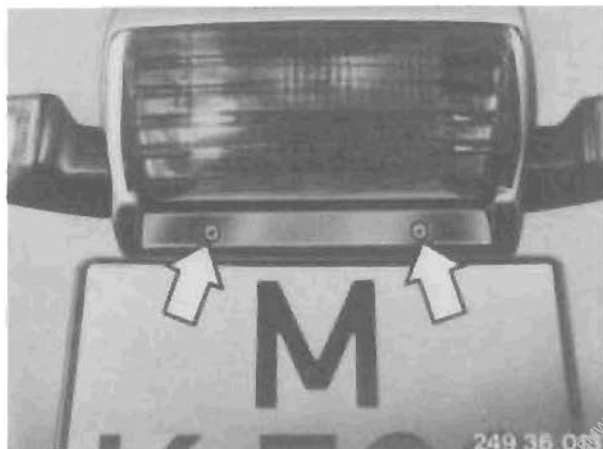

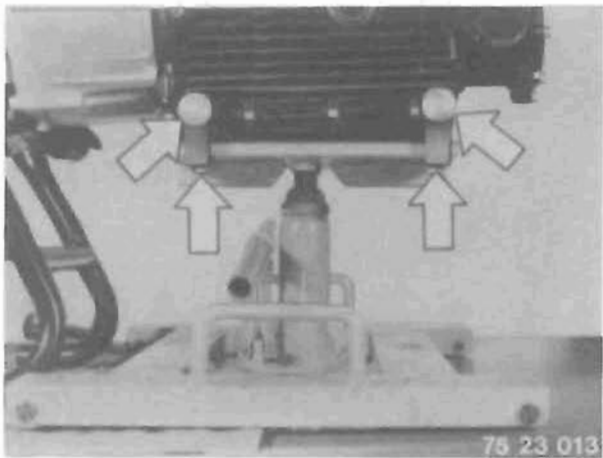

Slacken off the retaining screws (arrows) on the hoist, BMW No. 00 1 510, at the oil sump and detach the hoist.

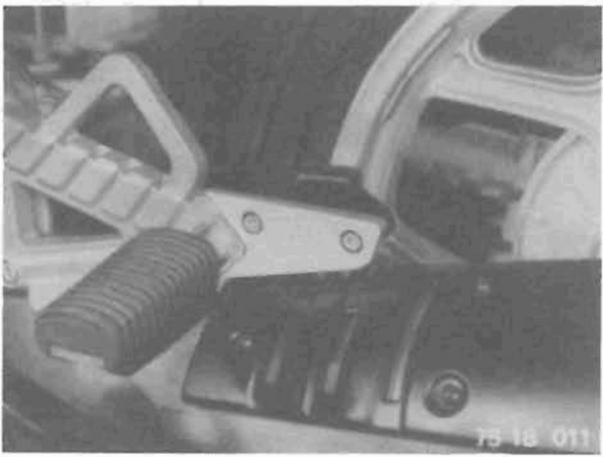

Exhaust system – installing

First secure the silencer loosely to the footrest plate with only one screw,

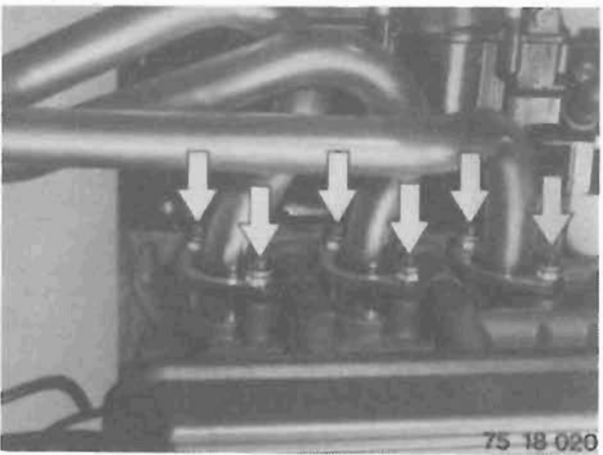

then secure the exhaust pipe to the cylinder head with a new seal and tighten. Attach a second screw for the silencer mounting and tighten both screws.

Tightening torque:

Exhaust pipe on cylinder head

$21 \pm 2 \text{ Nm}$

Silencer on footrest plate

$9 \pm 1 \text{ Nm}$

Install the ignition coil cover and tighten the retaining screw (not on K 75).

Frame fixation on driving device

K 100 (with fuel tank bridge mounting)

Insert screws 1 and 2 and tighten.

Insert screw 3 and tighten.

Insert screws 4 and 5 and tighten.

Tightening torque:

45 – 6 Nm

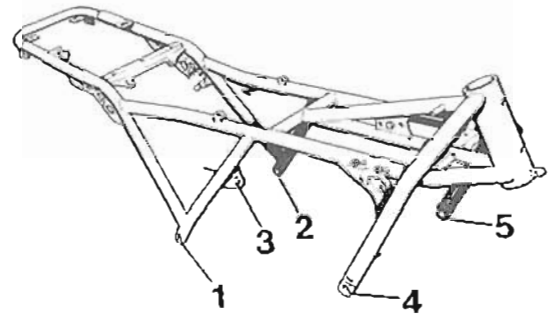

249 46 064

K 100 RS, RT (with fuel tank bridge mounting)

Insert screws 1, 2 and 3 and tighten.

Measure gap between engine and frame at 4 and 5 and fill with shims, leaving a gap of no more than 0.25 mm.

Insert screws and tighten.

Tightening torque:

45 – 6 Nm

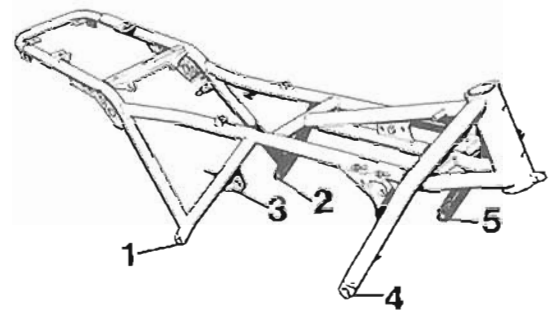

249 46 065

K 100, K 75c, s (Fuel tank plug mounting)

Insert screws 1, 2, 4 and tighten 1 and 2.

Measure the gap between the frame and eye on the intermediate flange and fill with shims, leaving a gap of no more than 0.25 mm.

Insert screw 3 and tighten.

Insert screw 5 tighten 4 and 5.

Tighten torque

45 – 6 Nm

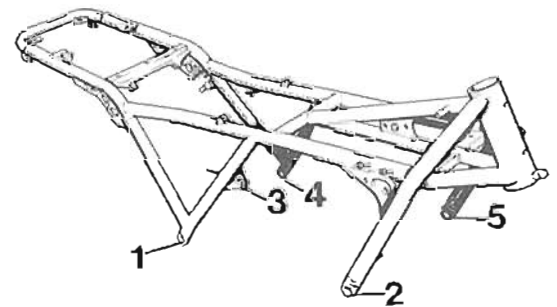

249 46 066

K 100 RS, RT (Fuel tank plug mounting)

Insert screws 1, 2, 4 and tighten 1 and 2.

Measure the gap between the frame and eye on the intermediate flange and fill with shims, leaving a gap of no more than 0.255 mm.

Insert screw 3 and tighten, tighten screw 4. Measure the gap between engine and frame at 5 and fill with shims.

Insert screw 5 and tighten.

Tightening torque

45 – 6 Nm

Note:

Install fairings: see Group 46.

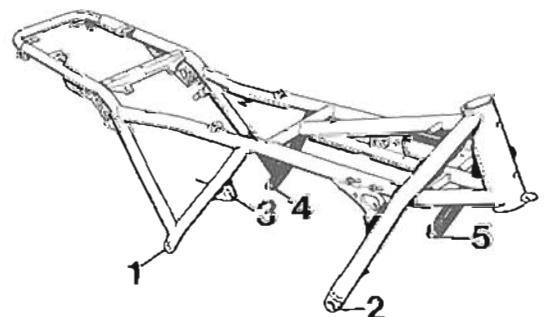

249 46 067

12

Engine – electrical system

12 Engine – electrical system

Specifications	Page	12-03.0
Tightening torques		12-05.0
Diagrams		12-07.0
Magnetic gate – removing and installing		12-11.0
Ignition timing – adjusting		12-12.0
Ignition control unit – removing and installing		12-15.0
Ignition coils – removing and installing		12-15.0
Ignition coils – connecting up		12-16.0
Alternator – removing and installing		12-16.0
Alternator driver – removing and installing		12-16.0
Starter – removing and installing		12-17.0
Starter – stripping down		12-17.0
Carbon brushes – renewing		12-17.0
Starter assembling		12-18.0

Engine
Specifications

Model	K 75	K 75 c	K 75 s	K 100	K 100 RS	K 100 RT	K 100 LT	
Starter motor	Permanent-magnet							
Ratio	27 : 1							
Rating	kW	0.7						
Starter relay make	Bosch							
Alternator	Three-phase, with integral all-electronic regulator							
Drive	Direct ratio 1 : 1.5							
Max. rating	W/V	460/14						
Max. current	A	33						
Charging commences	min ⁻¹	950 ± 50						
Max. speed	min ⁻¹	12300						
Coil make	Bosch							
Spark plugs								
Thread	M 12×1,25							
Bosch	X 5 DC			X 5 DC				
Beru	12-5 DU			12-5 DU				
Champion				A 85 YC				
Electrode gap	mm	0.6 + 0.1 when new; wear limit: 0.9						
Ignition system	All-electronic, breakerless microprocessor controlled digital system							
Ignition trigger	Two magnetic gates (Hall-effect transmitters) on crankshaft							
Ignition timing, static	°CS	6° bTDC ± 0.24 mm bTDC						
Max. ignition advance, dynamic – at engine speed	°CS min ⁻¹	32 4876...5120 und 7491...7876			30 5120...6022			
Max. ignition control range – at engine speed	°CS min ⁻¹	26 4876...5120 und 7491...7876			24 5120...6022			

Engine**Specification**

Model		K 75	K 75 c	K 75 s	K 100	K 100 RS	K 100 RT	K 100 LT
Average control range at low engine speeds	°CS min ⁻¹	22° 3530...3940			18° 3011...3530			
Ignition control begins	min ⁻¹	1300			1500			
Ignition control ends	min ⁻¹	8777			8650			

Engine – electrical system

Tightening torques

Connection	Nm
Starter to gearbox	6 ± 1
Cable connection on starter	4 to 6
Alternator to intermediate flange	21.5 ± 2
Coupling housing to alternator	45 ± 6
Magnetic gate plate to timing chain cover	3.5 ± 0.5
Adjusting plate for TDC	2.5 ± 0.5
Cover for Hall-effect transmitter	6 ± 1
Spark plug	20 ± 2
Ignition coils to intermediate flange	5 ± 0.5

Ignition system: diagram

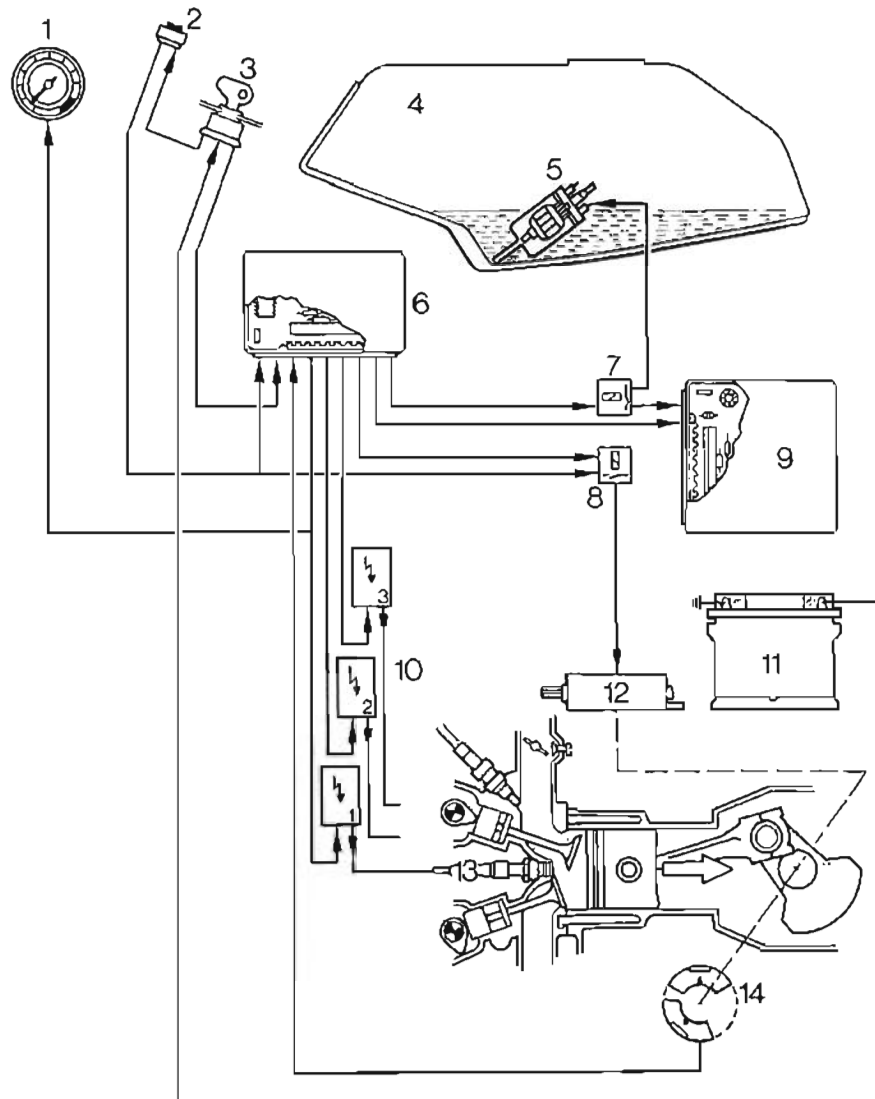

- | | |
|-------------------------|-------------------------------|
| 1 Revolution counter | 8 Starter relay |
| 2 Starter button | 9 Fuel injection control unit |
| 3 Ignition switch | 10 Ignition coils |
| 4 Fuel tank | 11 Battery |
| 5 Fuel pump | 12 Starter motor |
| 6 Ignition control unit | 13 Spark plug |
| 7 Fuel pump relay | 14 Hall-effect transmitter |

Ignition system: Hall-effect transmitter

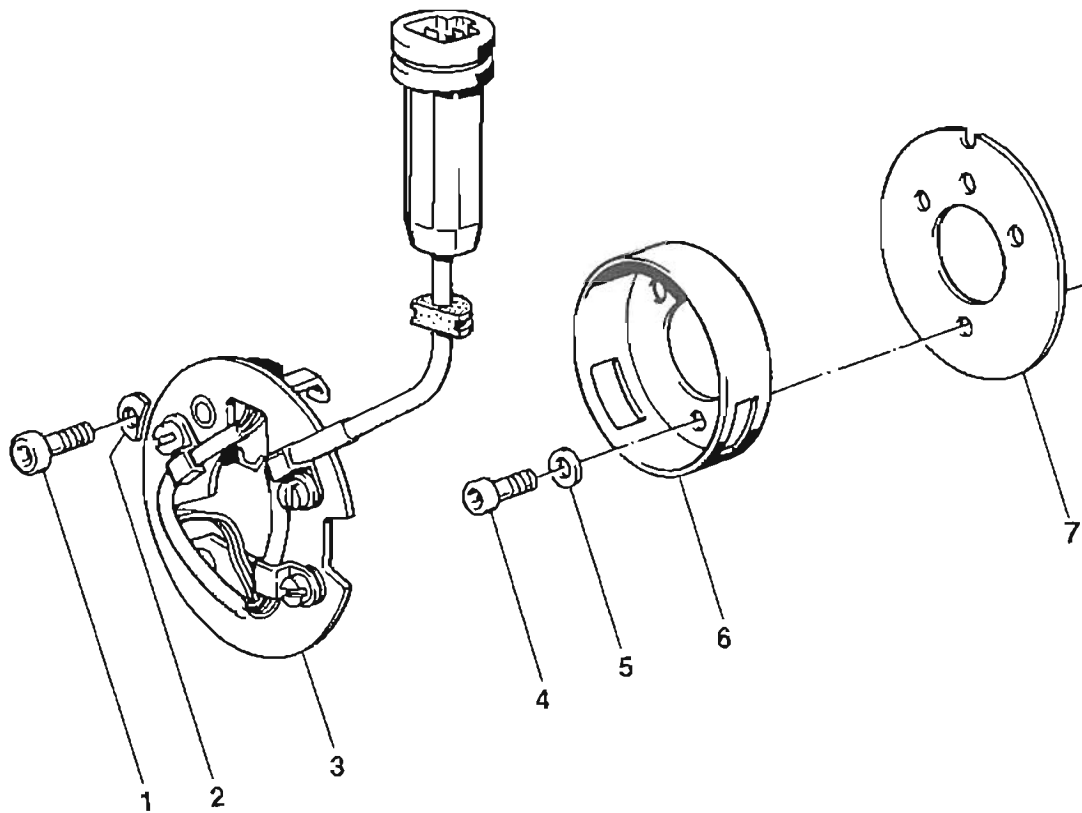

- 1 Retaining screw (M5×12)
- 2 Underlay washer
- 3 Magnetic gate with board and cable
- 4 Retaining screw (M4×10)
- 5 Underlay washer
- 6 Rotor
- 7 Shim for top dead centre

Starter motor

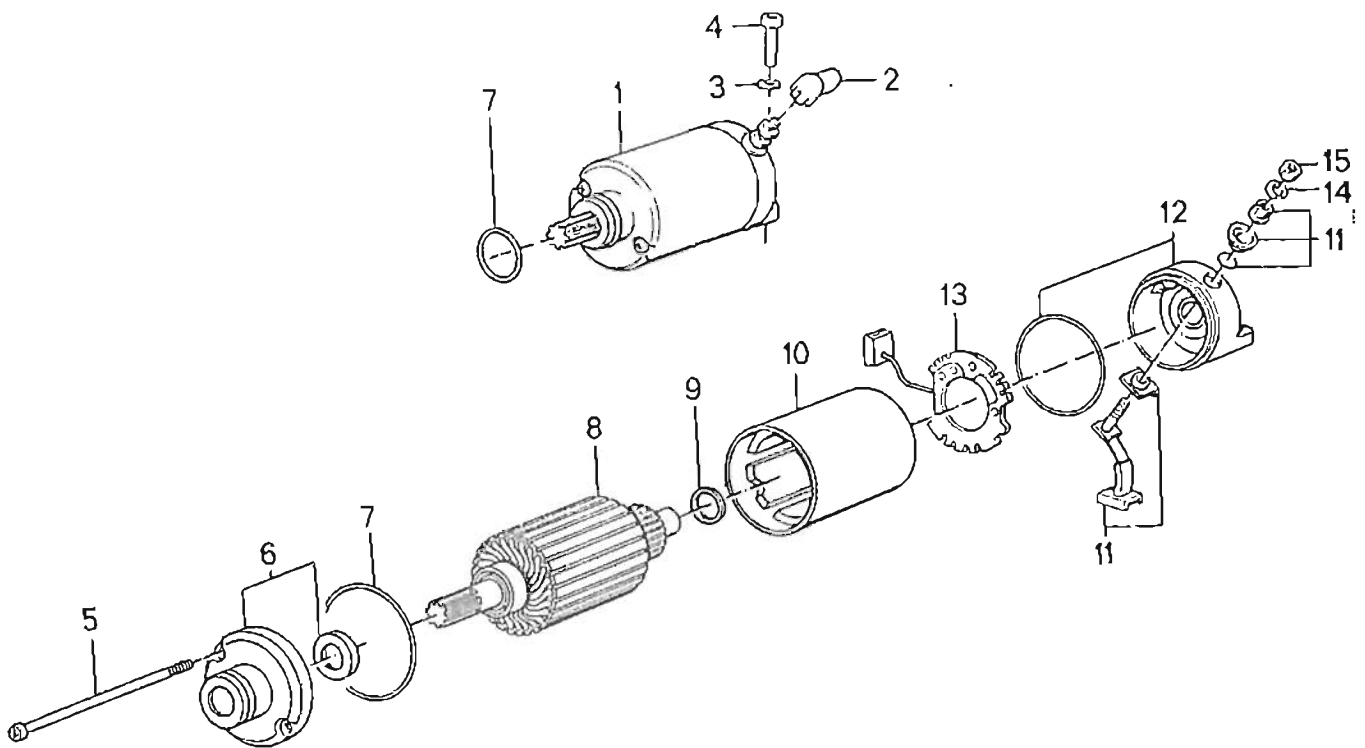

- 1 Starter motor
- 2 Protective cap
- 3 Spring washer
- 4 Machine bolt
- 5 Machine bolt
- 6 Drive end bearing
- 7 Repair kit – starter motor

- 9 Shim
- 10 Exciter winding
- 11 Carbon brush set
- 12 Commutator bearing
- 13 Brush mounting plate
- 14 Spring washer
- 15 Hex nut

Alternator

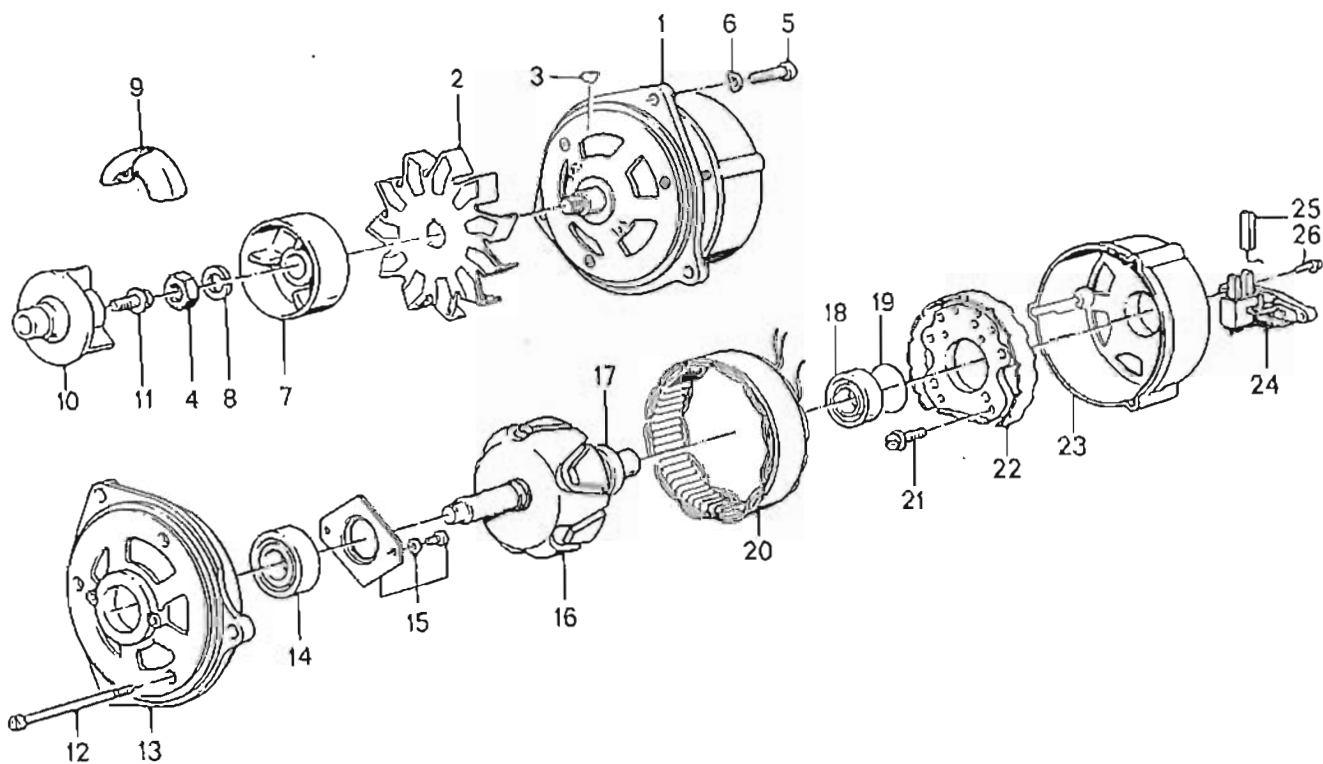

- 1 Alternator
- 2 Fan wheel
- 3 Key
- 4 Hex nut
- 5 Machine bolt
- 6 Spring washer
- 7 Clutch housing
- 8 Spring washer
- 9 Rubber bearing
- 10 Driver
- 11 Screw
- 12 Machine bolt
- 13 Drive end bearing

- 14 Deep-groove ball bearing
- 15 Cover
- 16 Rotor
- 17 Slipring
- 18 Deep-groove ball bearing
- 19 O-ring
- 20 Ring winding
- 21 Screw
- 22 Diode plate
- 23 Slipring bearing
- 24 Regulator
- 25 Carbon brush set
- 26 Screw

Magnetic gate – removing and installing

Remove fuel tank (see page 16 – 07.0)

Remove ignition trigger cover

Removing engine spoiler: see Group 46.

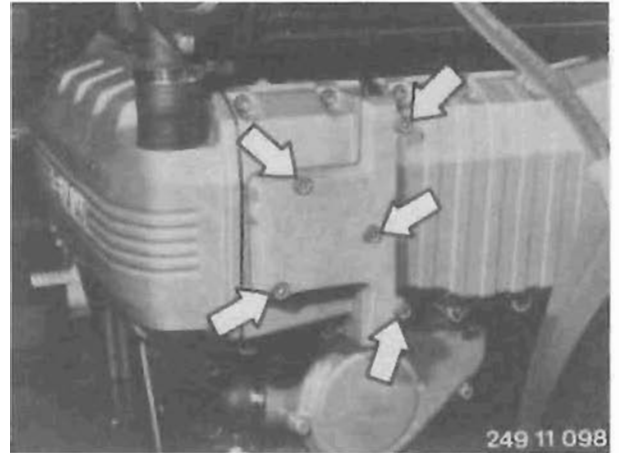

Release the clamp screws (arrows) and take out the magnetic gate board.

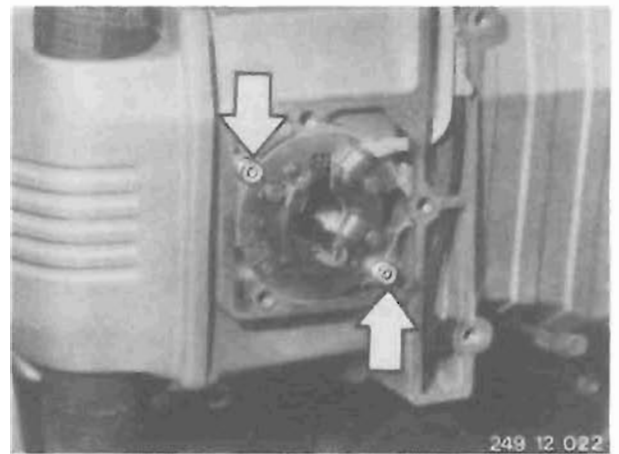

Separate the plug connection (arrow) for the Hall-effect generator.
Separate the 4 cable connectors and take off the magnetic gate board.



Installation sequence:

- Secure the magnetic gate board with 2 retaining screws.

When installing:

To achieve the basic magnetic gate setting, the recesses in the board and housing must be aligned.

- Carefully install the magnetic gate cable with 4 cable connectors.
- Make the plug connections.
- Time the ignition (see page 12 – 12.0).
- Screw on the ignition trigger cover.

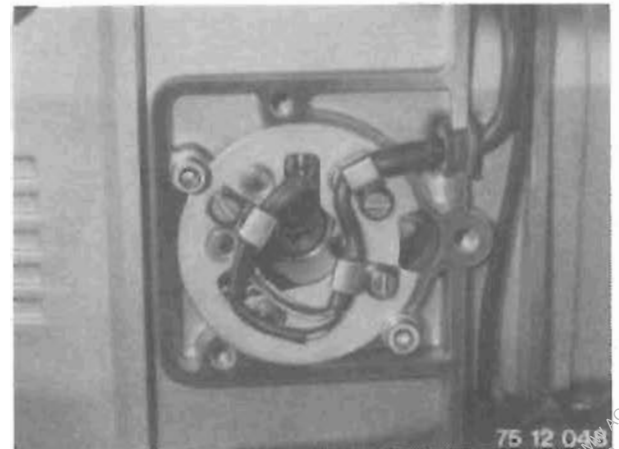

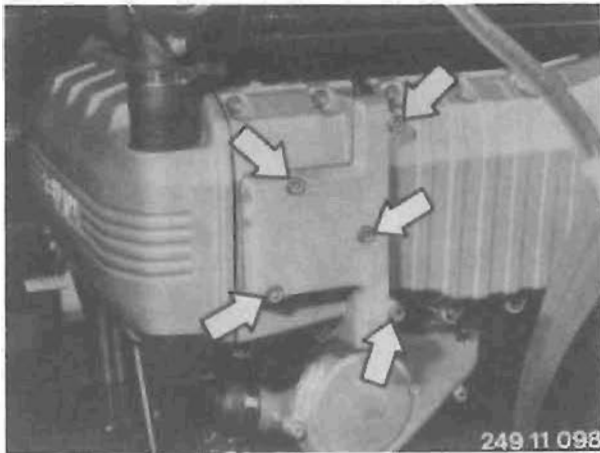

Ignition – timing

This motorcycle is equipped with a microprocessor-controlled digital ignition system of higher performance than conventional systems. Note that a dangerous or even *fatal accident* can occur if any live components are touched when the engine is running.

Remove fuel tank (see page 16–07.0).

Remove the ignition trigger cover.

Removing engine spoiler: see Group 46.



Separate the plug connector between the Hall-effect transmitter and the ignition control unit (arrow) at the top right frame tube.

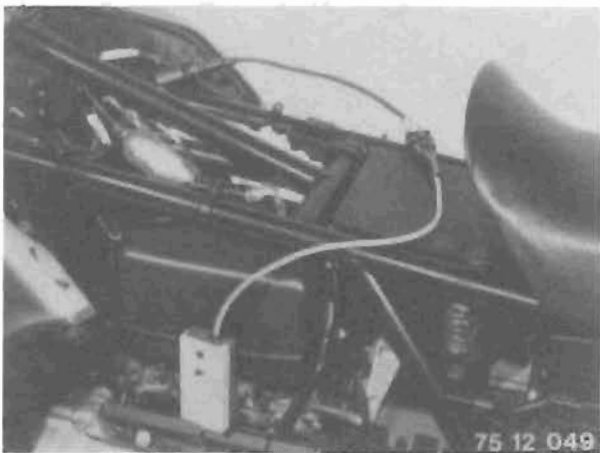

Connect adapter line BMW 12 3 651 (arrow) to the line from the Hall-effect transmitter, then connect the ignition timer, BMW 12 3 650.



Slacken off the 3 spark plug cover retaining screws. Pull of the spark plug caps with flat pliers.

Using spark plug wrench BMW 12 3 500, remove the spark plugs.

Note:

Be careful to unscrew the plugs without tilting the wrench or else there is a danger of breaking the ceramic insulator.

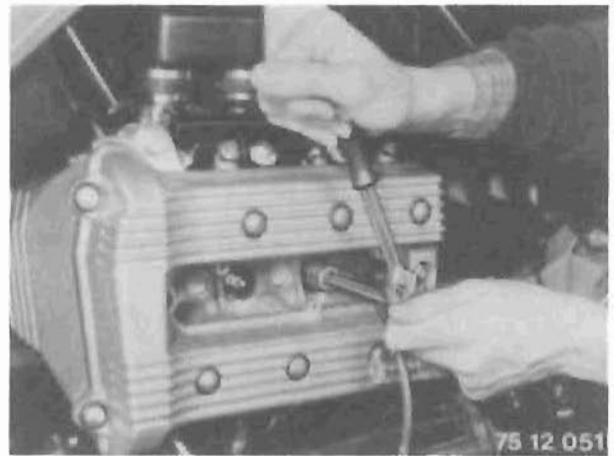

Screw the dial gauge extension, BMW 00 2 580, with dial gauge in cylinder 3.

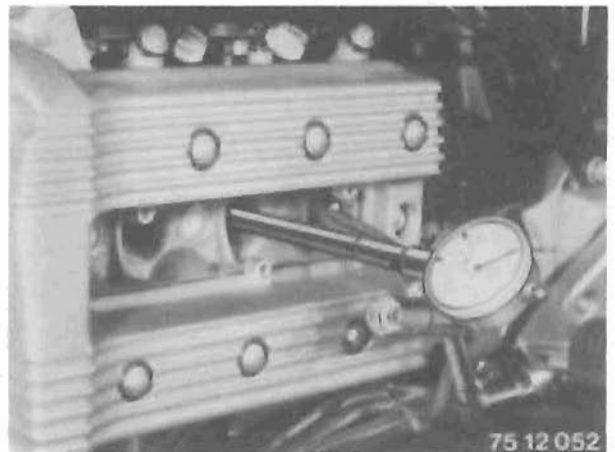

Screw the dial gauge extension, BMW 00 2 580, with dial gauge in cylinder 1.



Turn the crankshaft and use the dial gauge to determine top dead centre.

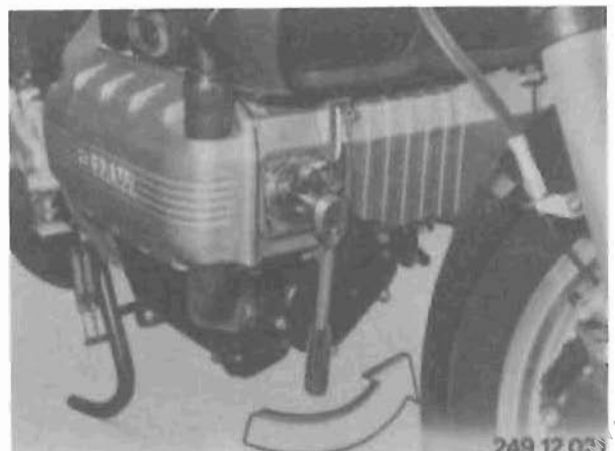

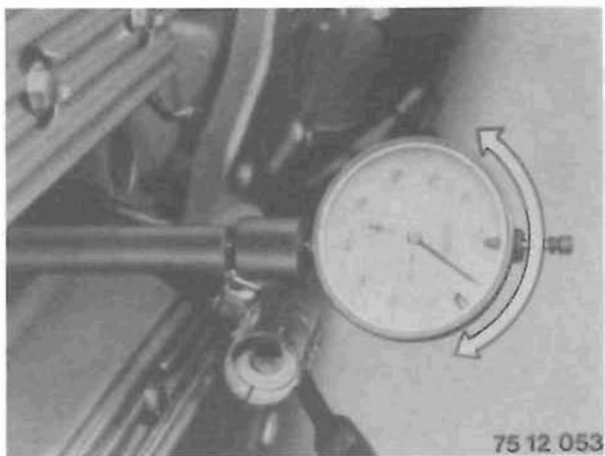

Turn the knurled ring with the scale to align the "0" on the measuring scale with the pointer.



Turn the engine opposite to its normal direction of rotation until the piston is at the firing point.

Ignition firing point = 0.24 mm before TDC (TDC = top dead centre).

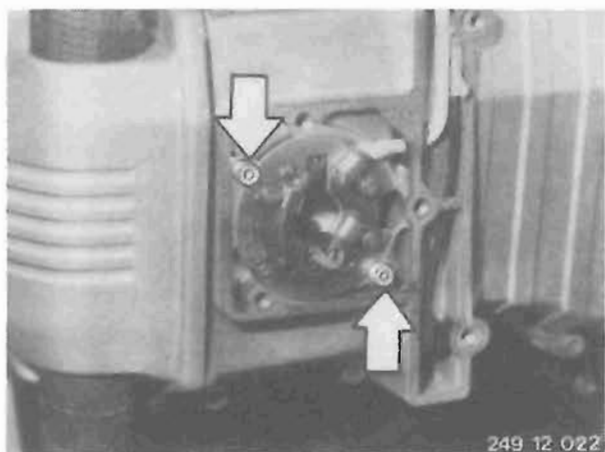

After loosening the two clamp screws (arrows), turn the magnetic gate board slowly to the left or right (ignition retard or advance) until the diode on the ignition timer goes out.

Tighten the clamp screws.

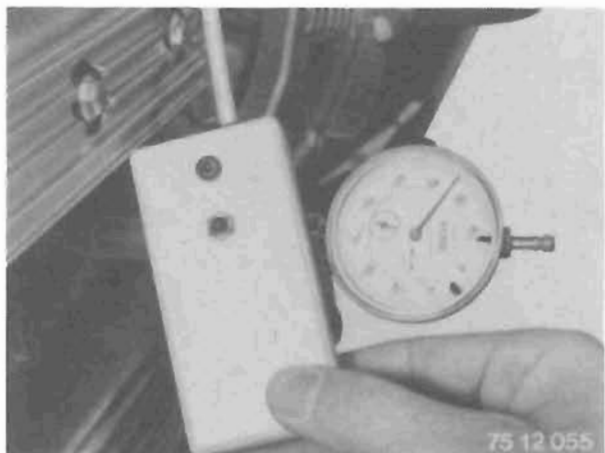

Check the ignition timing:

Turn the engine a full revolution. When the piston is located at 0.24 mm before TDC (indicated by dial gauge) the diode (arrow) on the ignition timer must come on.

Ignition control unit – removing and installing

Removing and installing fuel tank: see page 16–07.0.

Push back the water protection cap and pull the multi-pin plug out of the ignition control unit.

Slacken off the retaining screws on the left and right (arrows).

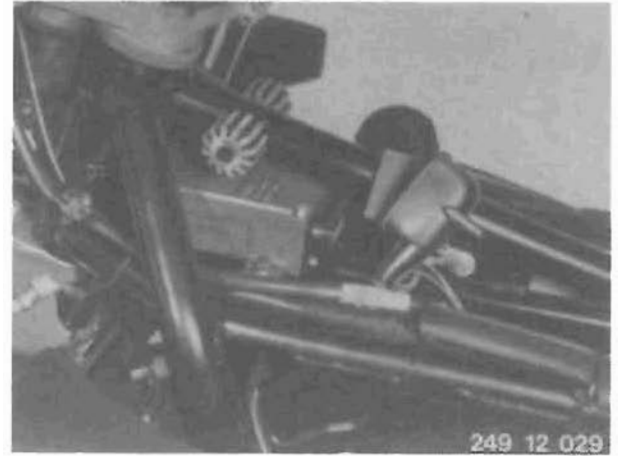

Pull back the ignition control unit until the lug (arrow) is completely removed from the steering head. Take out the ignition control unit to the left or right.



Ignition coils – removing and installing



Slacken off and remove the three retaining screws on the ignition coil cover, and take off the cover.

Pull off the two-pin plug on the ignition coils, earth lead (2) on the third ignition coil and the spark plug caps.



Slacken off and remove the four retaining screws on the ignition coil cover, and take off the cover.

Pull off the lines to terminals 1 and 15, the earth leads to both ignition coils and the spark plug caps.

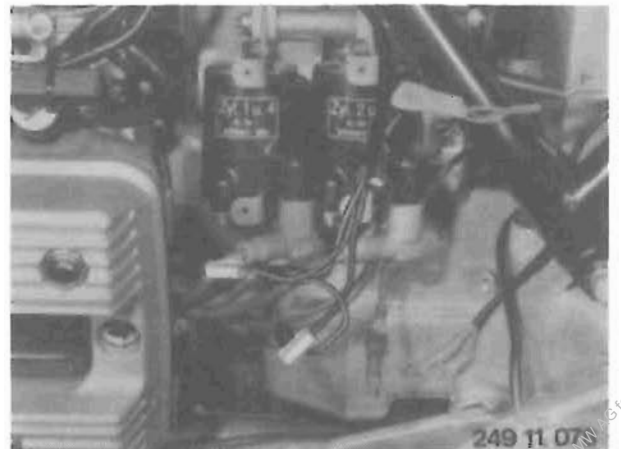

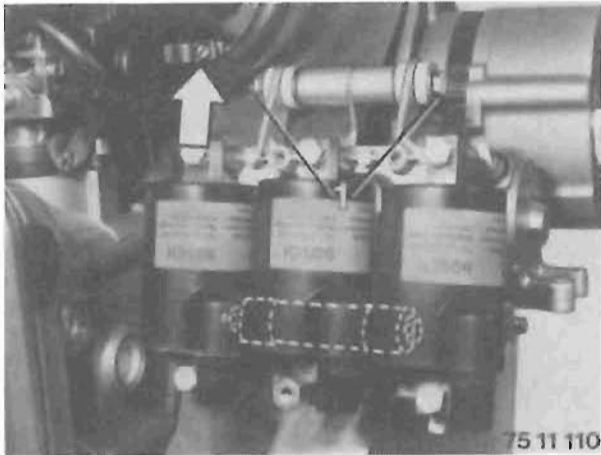

Slacken off the bearing pins for the ignition coil mounting at the top and bottom and remove, firmly holding the ignition coils. When installing secure the ignition coil mounting first at the bottom and then at the top.

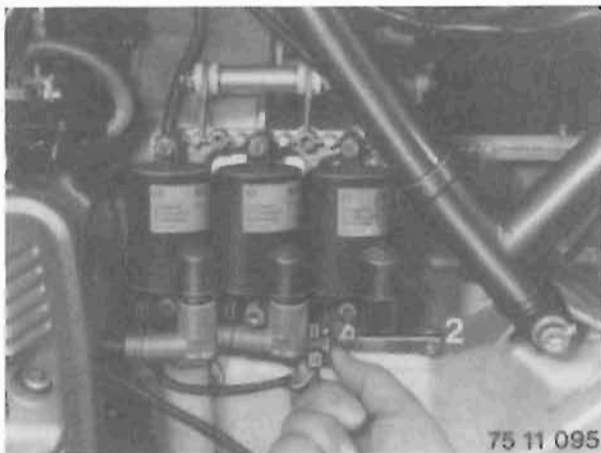

Ignition coils – connecting up



Secure earth lead (2) to ignition coil 3, push on two-pin plug.

Ignition coil 1: two-pin plug with blue/black cable

Ignition coil 2: two-pin plug with red/black cable

Ignition coil 3: two-pin plug with green/black cable



Secure leads to terminals 1 and 15.

Note the instructions on the ignition coils. Push on the earth lead.

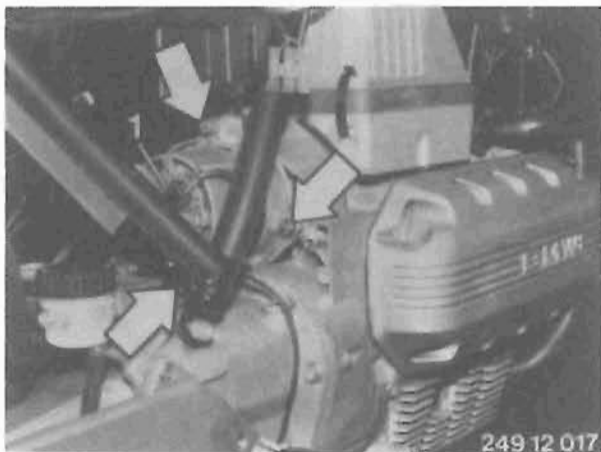

Alternator – removing and installing

Remove control unit for fuel injection system (see page 13–14.0). Remove battery (Group 61).

Take the coolant header tank out of the battery mounting plate.

Remove the three retaining screws (arrows) and take out the two-pin plug (1).

Install following the same procedure but in the reverse sequence.

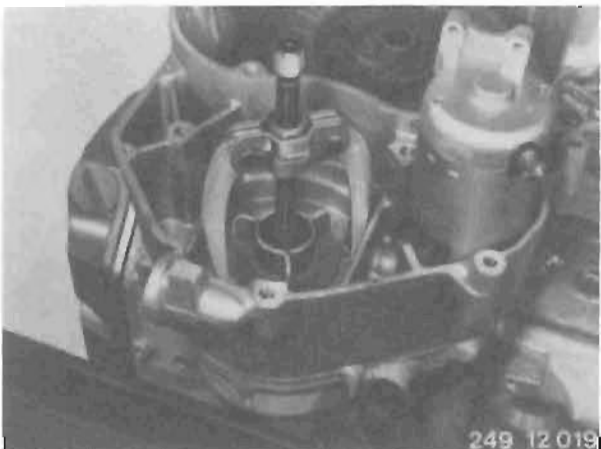

Alternator driver – removing and installing

Remove the alternator (see above).

The illustrations supplied are with the engine removed.

Pull off the driver flange with two-arm puller BMW

00 8 400, and small pressure head of universal puller,

BMW 00 7 500.

Note:

Grind down the claws of the puller until slightly thinner if necessary.

Install following the same procedure but in the reverse sequence.

Starter motor – removing and installing

Remove control unit for fuel injection system (see page 13–14.0).

Remove battery (see Group 61).

Remove ignition coil cover.

Detach positive lead on starter motor.

Slacken off and remove retaining screws (arrows) on starter motor.

Pull out starter motor to the rear.

Install following the same procedure but in the reverse sequence.

Tightening torque:

Retaining screws $7 \pm 1 \text{ Nm}$

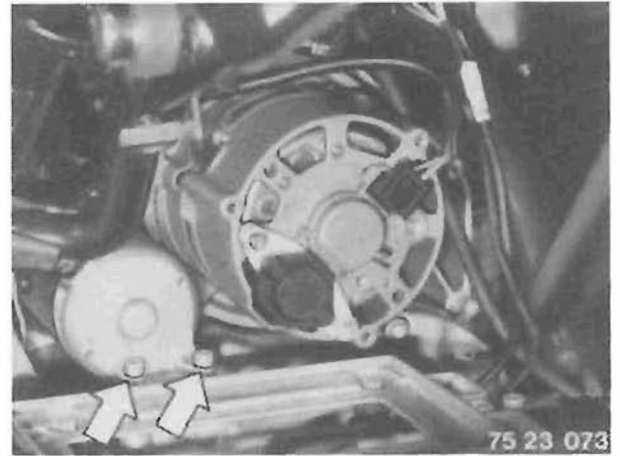

Starter motor – stripping down

Clamp starter motor in vice with protective jaws (as illustrated).

Slacken off and remove the retaining screws (arrows).

Pull off drive end bearing (6).

Pull off housing with stand (10).

Pull rotor (8) out of commutator bearing (12).

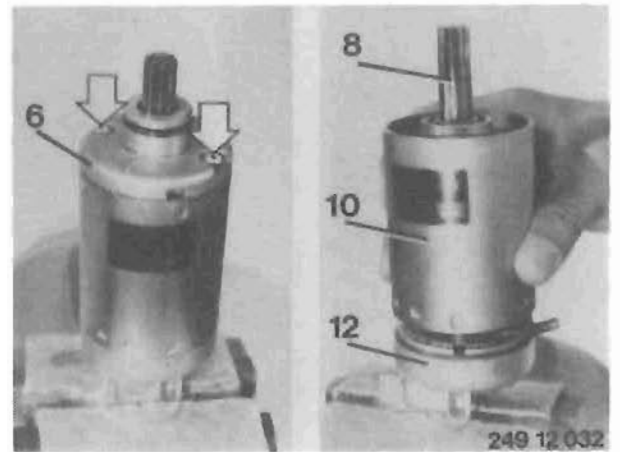

Remove retaining nut (arrow) for brush element.

Note:

Note washer and O-ring.

Remove brush mounting plate (13).

Take out commutator bearing.

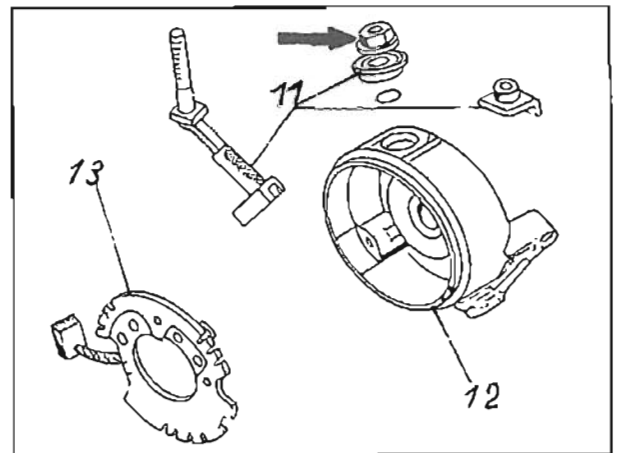

Carbon brushes – renewing

Lever off the spring with a small screwdriver and take out the carbon brush (arrow).

Install following the same procedure but in the reverse sequence.

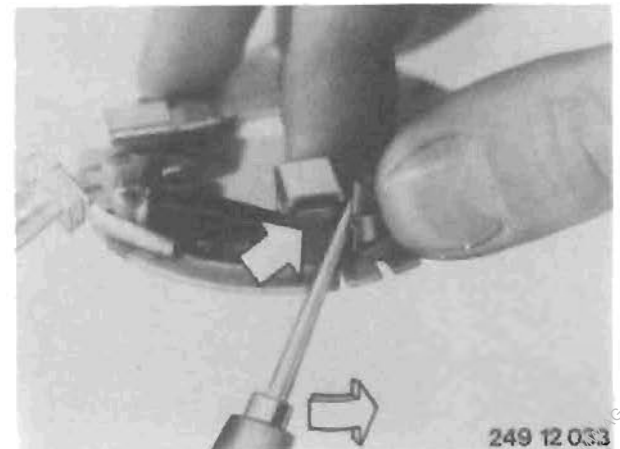

Starter motor – assembling

Clamp commutator bearing (12) in vice with protective jaws and fit O-ring.

Fit brush mounting plate (13) in such a way that the notches in the commutator bearing (arrows, illustration on left) are aligned with the brush mounting plate.

Insert rotor (8) in the commutator bearing (illustration, right).

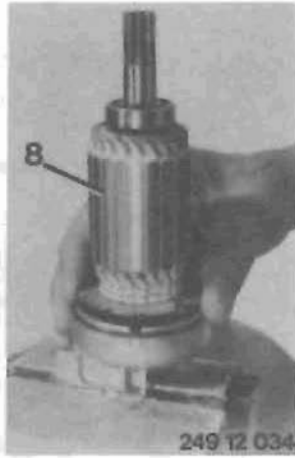
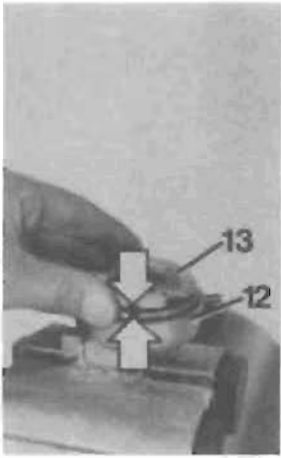

Insert housing with stand (10) in such a way that the large lug fits in the notches (arrows, illustration on left).

Fit the O-rings (7) on the drive end bearing.

Fit the drive end bearing in such a way that the notch points towards the front (arrow, illustration on right).

Tighten the retaining screws (arrows).

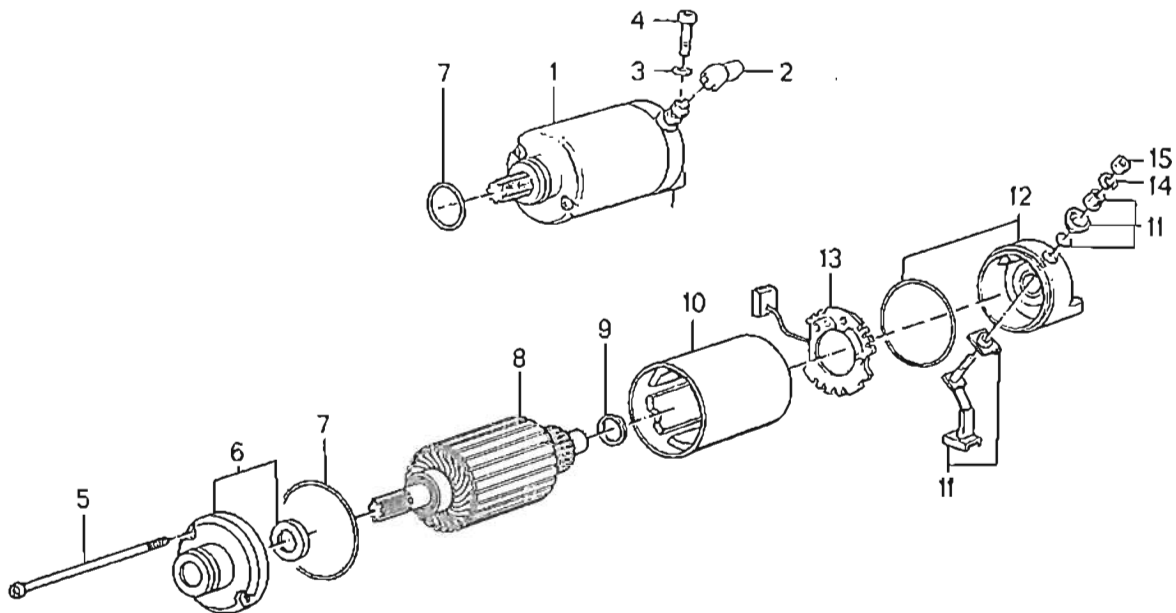

13

Fuel supply and mixture control

13 Fuel supply and mixture control

Diagrams	Page 13-03.0
Engine idle speed – adjusting	13-07.0
Increased starting speed – adjusting	13-08.0
CO-value – adjusting	13-08.0
Throttle butterfly switch – removing and installing	13-09.0
Throttle butterfly assembly – removing and installing	13-10.0
Air cleaner element – checking, removing and installing	13-12.0
Pressure regulator – removing and installing	13-13.0
Fuel injection control unit – removing and installing	13-14.0
Air flowmeter – removing and installing	13-16.0

Fuel injection system: diagram

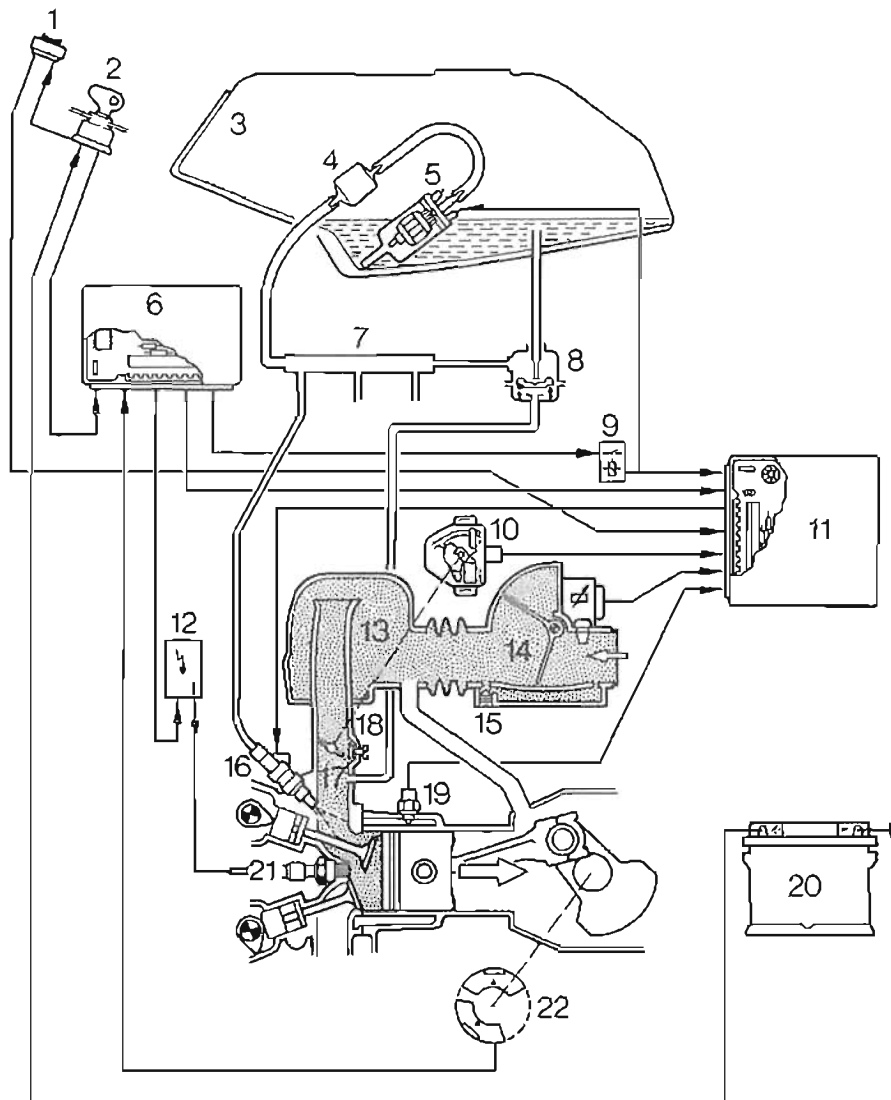

- | | | |
|-------------------------|---------------------------------|-------------------------------------|
| 1 Starter switch | 9 Fuel injection relay | 16 Injectors |
| 2 Ignition switch | 10 Throttle butterfly switch | 17 Throttle butterfly |
| 3 Fuel tank | 11 Fuel injection control unit | 18 Bypass passage for engine idling |
| 4 Fuel filter | 12 Ignition coils | 19 Temperature sensor |
| 5 Fuel pump | 13 Air collector | 20 Battery |
| 6 Ignition control unit | 14 Air flowmeter | 21 Spark plug |
| 7 Fuel gallery pipe | 15 Idle mixture adjusting screw | 22 Hall-effect transmitter |
| 8 Pressure regulator | | |

Intake air system

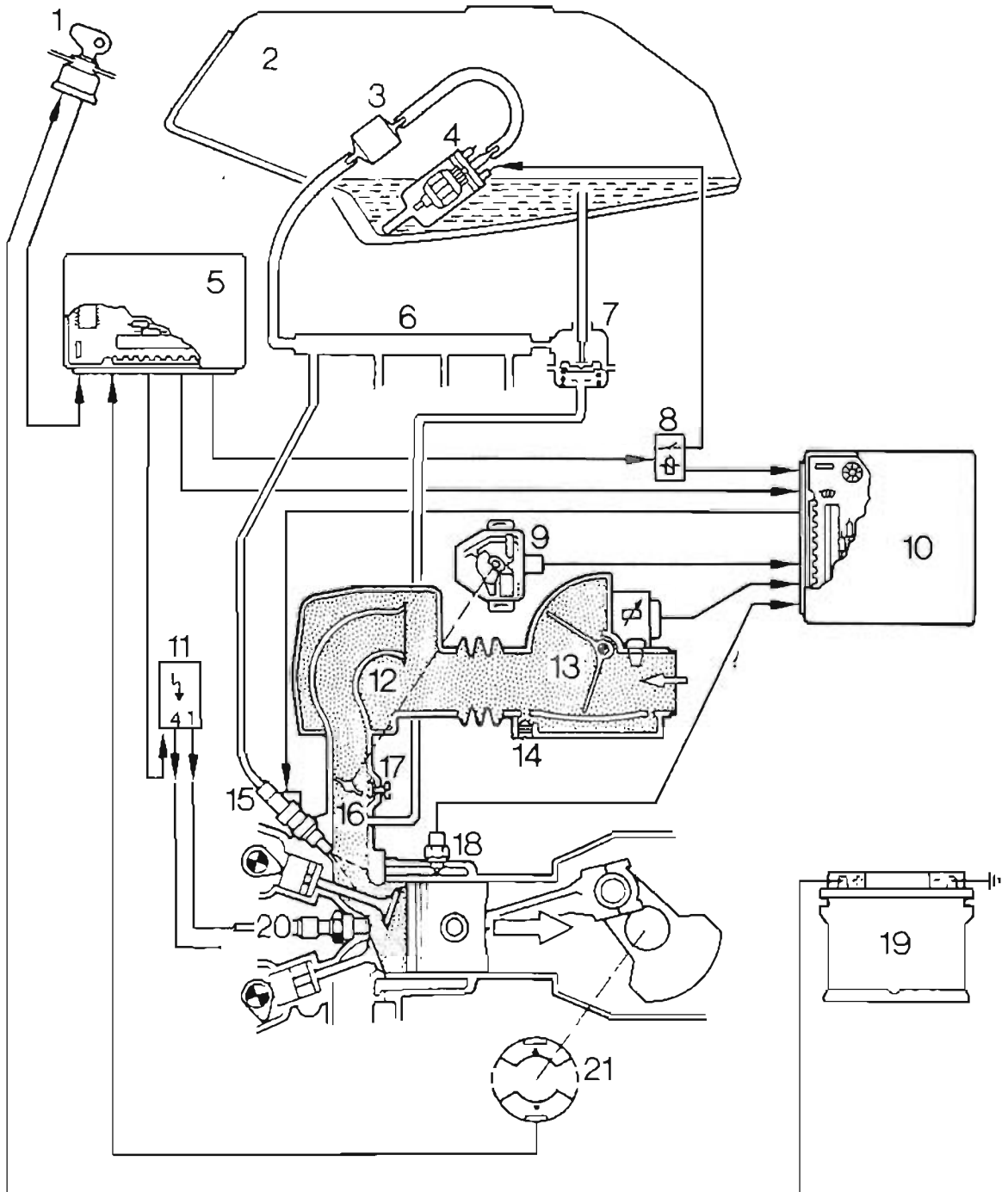

- 13 Air collector
- 14 Air flowmeter
- 15 Bypass air screw
- 17 Throttle butterfly
- 18 Idle speed adjusting screw

Engine idle speed – adjusting

Adjust engine idling only with the engine at its normal operating temperature of app. 85°C.



K 100 RT and LT: see Group 46 for removing and installing lower fairing.

K 100 RS: see Group 46 for removing and installing knee pads.

Remove the sealing plugs at the vacuum unions (arrows) and the line from pressure regulator (1).

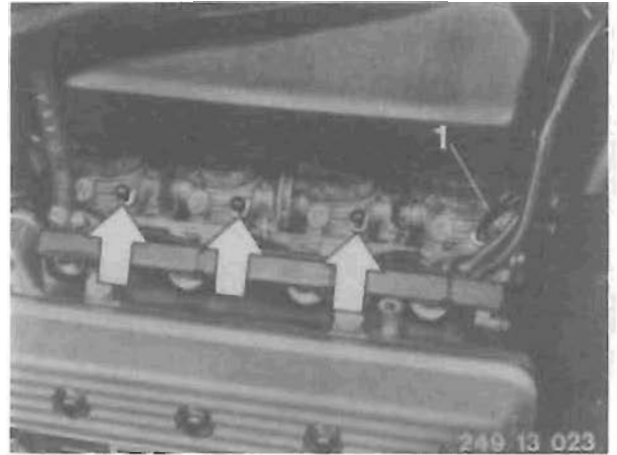

Connect 'Synchrotester' BMW 13 0 700 with adapters BMW 13 0 702 (arrows) to the vacuum unions for cylinders 1 and 2.

Connect adapter BMW 13 0 703 (1) to cylinder 3 and push hose (2) from the pressure regulator on to the T-union.



Connect 'Synchrotester' BMW 13 0 700 with adapters BMW 13 0 702 (arrows) to the vacuum unions for cylinders 1 to 3.

Connect adapter BMW 13 0 703 (1) to cylinder 4 and push hose (2) from the pressure regulator on to the T-union.

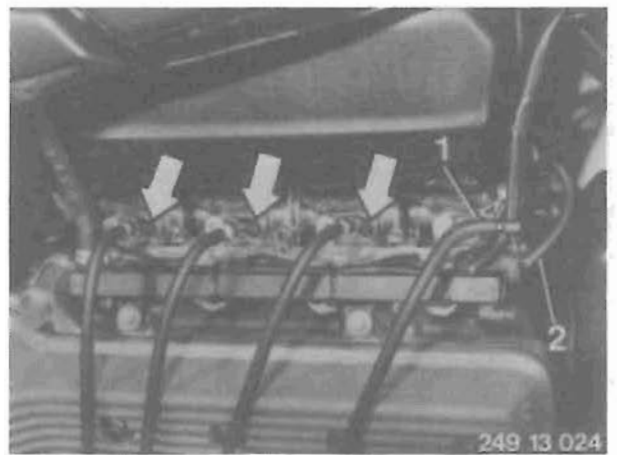

Turn the individual recirculating-air screws (arrows) to right or left until the cylinders are synchronized; the three (four) mercury columns must be at the same level.

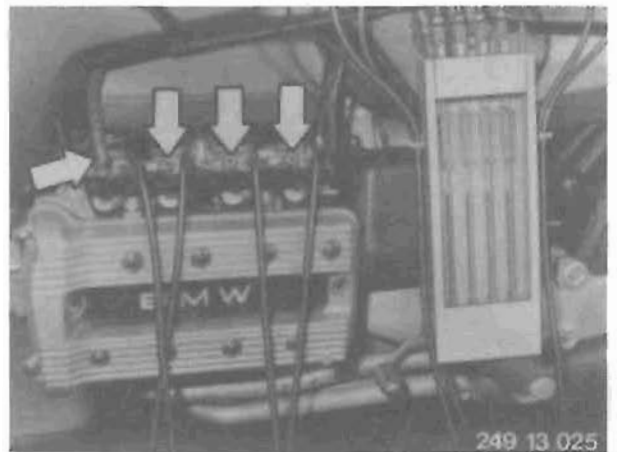

Adjust idle speed at the idle adjusting screw (arrow).
Idle speed $950 \pm 50 \text{ min}^{-1}$

Note:

If the throttle twistgrip is turned slightly, a clicking sound should be heard clearly from the idle switch. If not, the idle adjusting screw has been tightened too far.

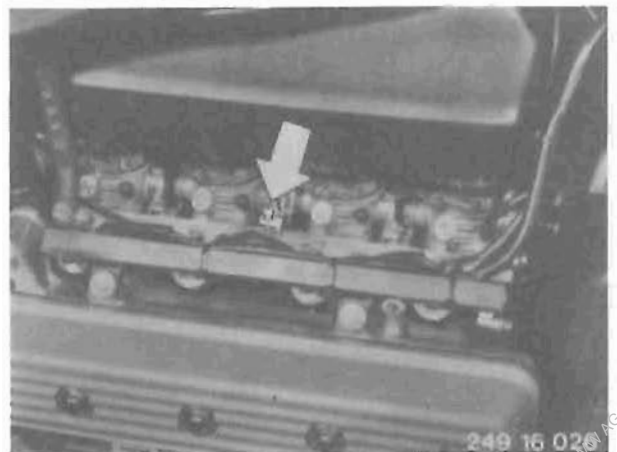



Increased starting speed – adjusting

The increased starting speed is adjusted at adjusting screw (1). To turn the screw, slacken off locknut (2).

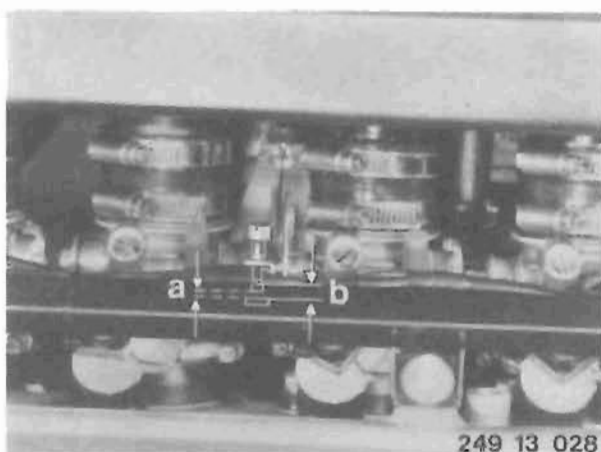

Push the increased starting speed control on the handlebar to stage 1 and turn the adjusting screw (1) until the idle speed adjusting screw has been lifted by dimension "a" (1.5 mm). In stage 2, dimension "b" (3.5 mm) must then result.



Dimension "a" = 1.5 mm

Dimension "b" = 3.5 mm



Dimension "a" = 1 mm

Dimension "b" = 2.5 mm



CO-value – adjusting



RT and LT: removing and installing lower right-hand fairing.

RS: removing and installing knee pads (see Group 46).

Set up the CO-value test equipment according to the manufacturer's instructions.

- The ignition timing must be correct.
- Increased starting speed lever in position 0.
- The throttle butterfly assembly must be synchronized.
- Engine idle speed $950 + 50 \text{ min}^{-1}$.
- Engine at operating temperature (engine oil app. 85°C).
- The exhaust system must not have any leaks.
- To prevent fresh air entering the measuring probe, the probe must be inserted in the silencer by about 30 cm.

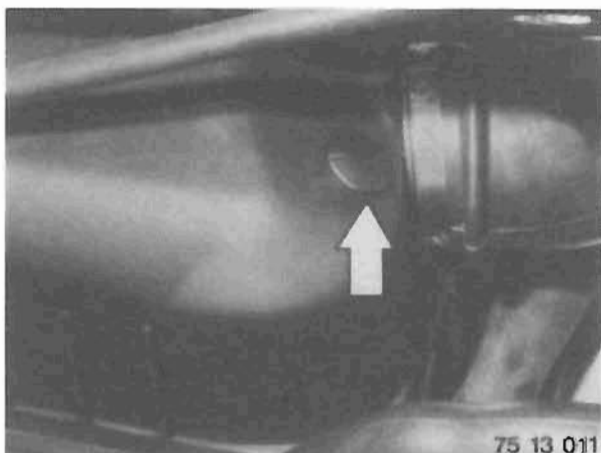

Take the cap (arrow) out of the top section of the air cleaner housing.

When installing:

The mark must face to the rear.

Turn the adjusting screw on the air volume gauge with a 5 mm Allen key.

The CO-value should not be greater than $2 \pm 0.5\%$ by volume. (The fuel tank has been removed here to provide a better illustration).

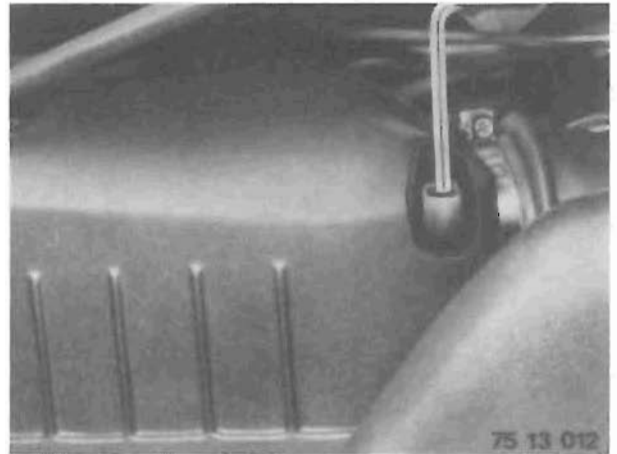

After taking the measurement, check engine idling with BMW 'Synchrotester' 13 0 700 and adjust if necessary.

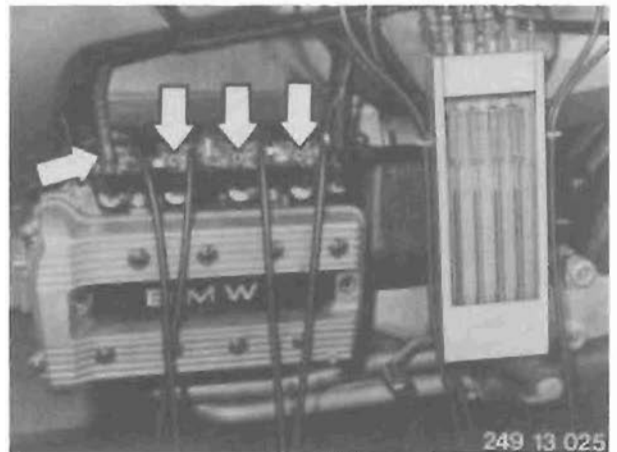

Throttle butterfly switch – removing and installing

Slacken off the retaining screws (arrows) for the throttle butterfly switch.



Pull the throttle butterfly switch off the throttle butterfly shaft. Pull off the multi-pin plug (arrow); loosen the wire keeper if necessary.

When installing:

Adjust the throttle butterfly switch (by rotating the shaft) so that a clear "clicking" noise is heard when the throttle twistgrip is turned.

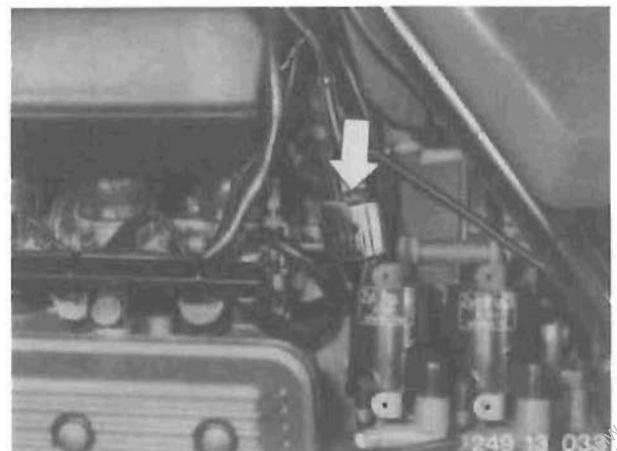

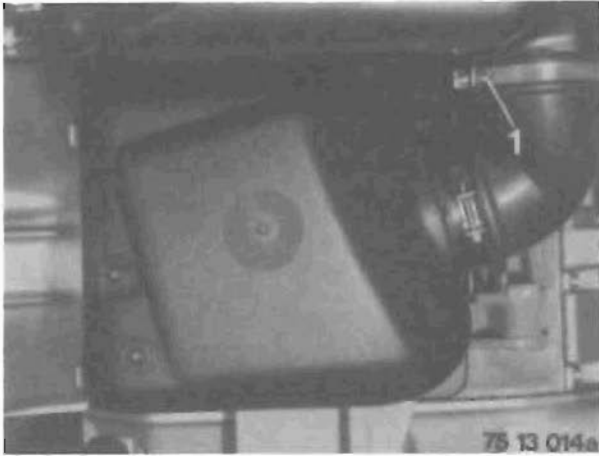

Throttle butterfly assembly – removing and installing

K 100 RS, RT, LT:

Remove knee pads (see Group 46).

Remove fuel tank (see page 16–07.0).

Remove lower fairings (see Group 46).

Pull intake tube off lower section of air cleaner housing and intake pipe.

Unscrew intake pipe on radiator.

Loosen hose connectors on air line at collector (1) at the air cleaner end (7 mm across flats) and pull off the air line.

Take out the upper section of the air cleaner housing.

Note:

The picture was taken with the engine removed to provide a better illustration.

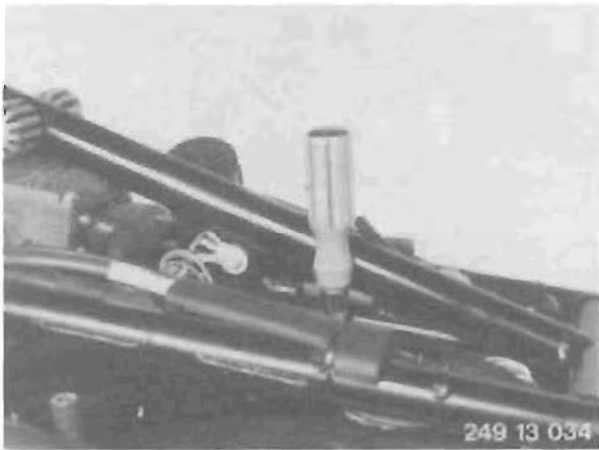

K 100, K 75, c, s:

Pull intake tube off lower section of air cleaner housing and Intake pipe.

K 100: unscrew intake pipe on radiator.

Remove fuel tank (see page 16–07.0).

Loosen hose connectors on air line at collector (1) at the top (see illustration) and pull off the air line.

Take out the upper section of the air cleaner housing.

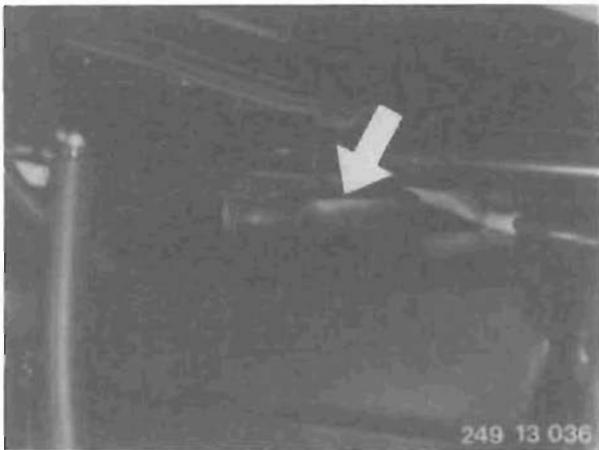

K 100 RS, RT, LT:

After releasing the cable connector, push the divider through the gap between the frame and air collector.

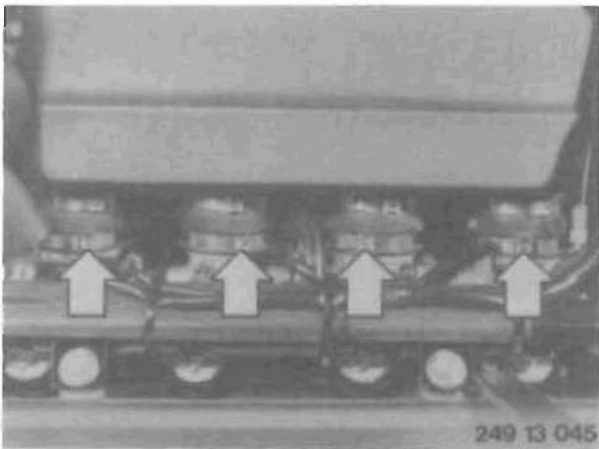

Dismantle the engine housing breather on the air collector. Release the one-way hose connectors (arrows) on throttle butterfly stub pipe with BMW pliers 13 1 500, remove and take out the air collector.

Pull off temperature sensor plug.
 Release retaining screws (arrows) and pull out injector rail with injectors.
 Tape off injector holes with adhesive tape.

Note:
 Divider (1) is only on K 100 RT and LT.

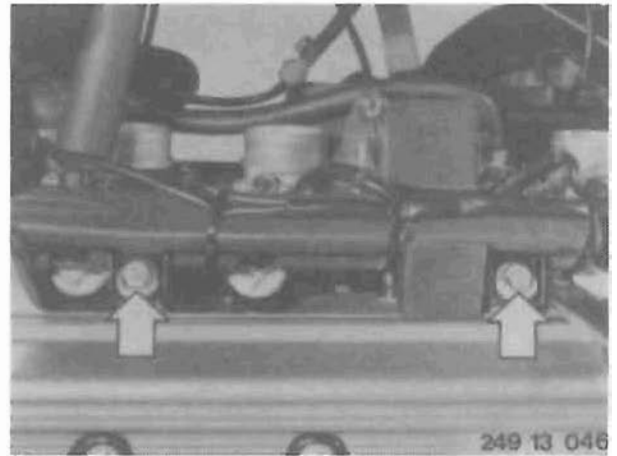

Pull off plug for butterfly throttle switch.
 Disconnect throttle cable (1) and cable for increased starting speed.

Warning:
 Do not bend the cables.

Release the screw-type hose connectors (arrows) on the throttle butterfly stub pipe at the engine end, pull off the plug for increased starting speed indicator on the wiring harness under the tank.
 Pull off the hose to the injector rail. Pull the throttle butterfly out of the pipe.

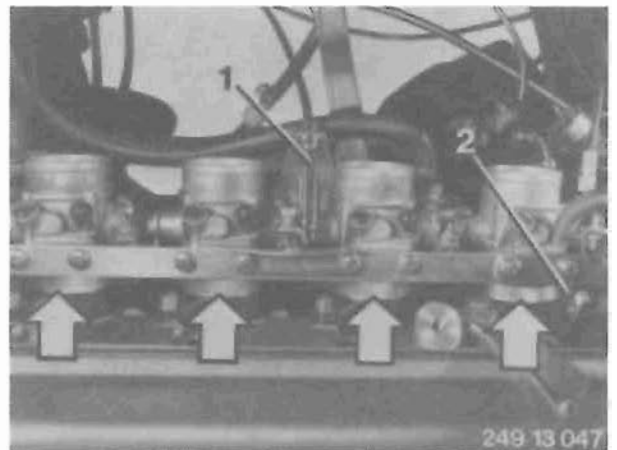

Only remove the switch for increased starting speed indicator (1) and pressure regulator (2) to change the throttle butterfly stub pipe assembly.



On K 100 up to frame number 0 008 130
 K 100 RS up to frame number 0 084 624
 K 100 RT up to frame number 0 027 887
 the vacuum pressure switch must also be removed when the throttle butterfly is changed.

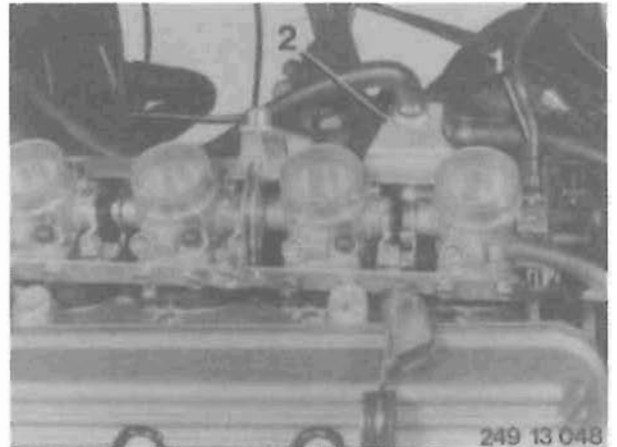

Fit the air collector to the throttle butterfly stub pipe assembly while dismantled.
 Fit the throttle butterfly assembly complete with air collector on the intake stub pipe.
 Tighten the hose connectors.

Note:



The hose connector to cylinder 3 must be fitted in such a way that the clamping screw is turned inward by app. 35° (to ensure sufficient play at the throttle butterfly shaft).

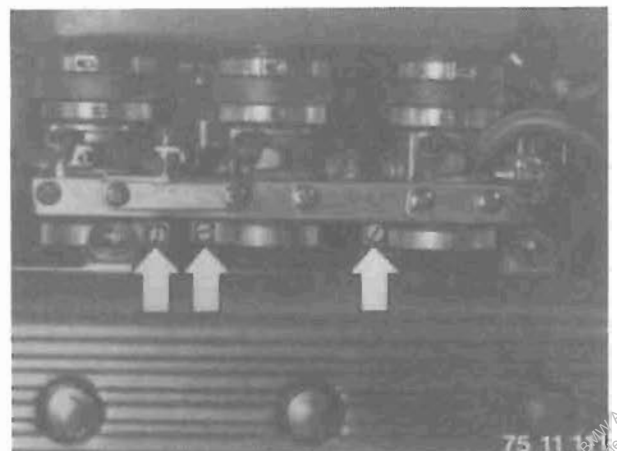

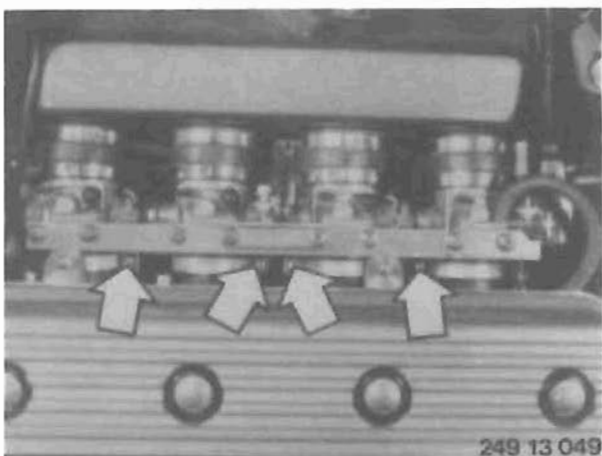

Note:



The hose connector to cylinder 4 must be fitted in such a way that the clamping screw is turned inward by app. 35° (to ensure sufficient play at the throttle butterfly shaft).

Continue installation by following the same procedure but in the reverse sequence.



Air cleaner element – checking, removing and installing

To check the air cleaner for contamination, increase engine speed to 2/3 of the nominal speed and read off the CO value.

Remove the air cleaner element and repeat the above procedure. If the CO value is now significantly lower, the air cleaner element must be renewed.



K 100 RS, RT, LT: Remove and install lower fairing (Group 46).

Pull the air intake line out of the bottom section of the air cleaner housing and pull it off the intake stub.

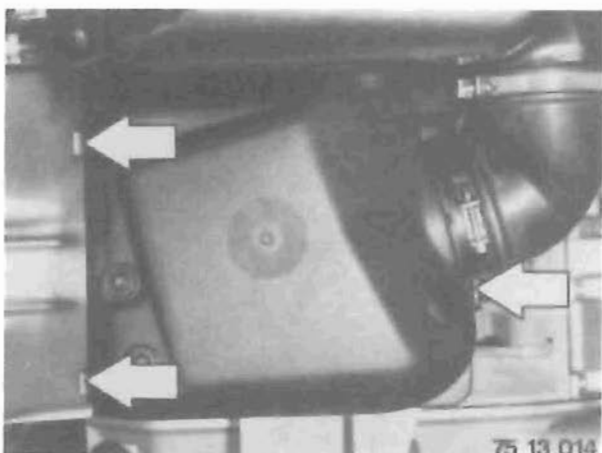

Slacken off the retaining clips (arrows) on the air cleaner housing.
(The picture was taken with the engine removed to provide a better illustration.)

Note:

Front retaining clip opens from the bottom upwards.

Lift the top section of the air cleaner housing and take out the air cleaner element.

When installing:

Make sure that the lugs are correctly seated; check that the lug on the left air collector side is properly engaged. Note correct installed position ("TOP" marking, should point towards the rear of the vehicle).

Install by following the same procedure but in the reverse sequence.

Check engine idling and adjust if necessary (see page 13-07.0).

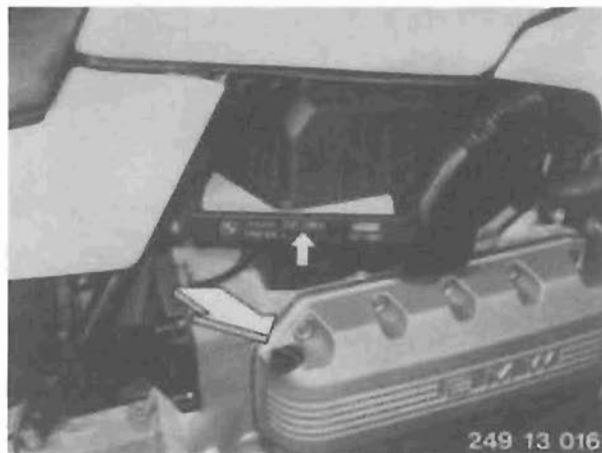

Pressure regulator – removing and installing

Remove the air cleaner element (see page 13-12.0).

Detach the hose connector (1) on the air collector.

Take out the upper section of the air cleaner housing.

(The picture was taken with the engine removed to provide a better illustration.)

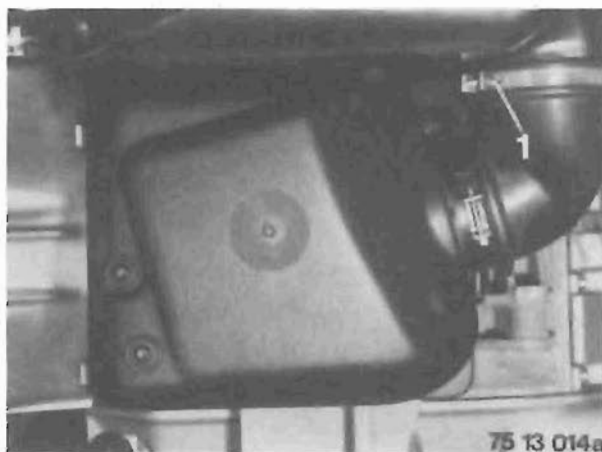

Slacken off the retaining clips (arrows) and take out the bottom section of the air cleaner housing.

Tightening torque:

Retaining screw 21 ± 2 Nm

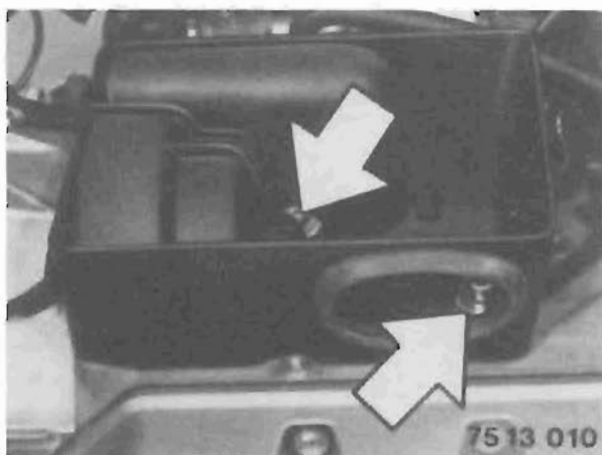

Release fuel lines (1) and (2) at the pressure regulator and pull them off.

Pull off the vacuum hose (3).

Slacken off the hex nut (arrow) and take the pressure regulator off the mounting plate.

Tightening torque:

Hex nut 25 ± 3 Nm

Install by following the same procedure but in the reverse sequence.

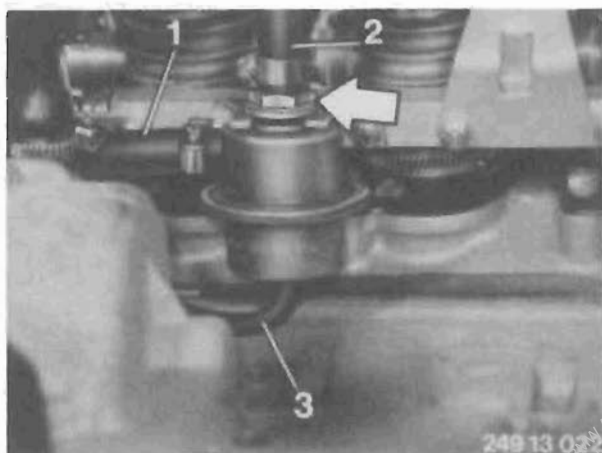

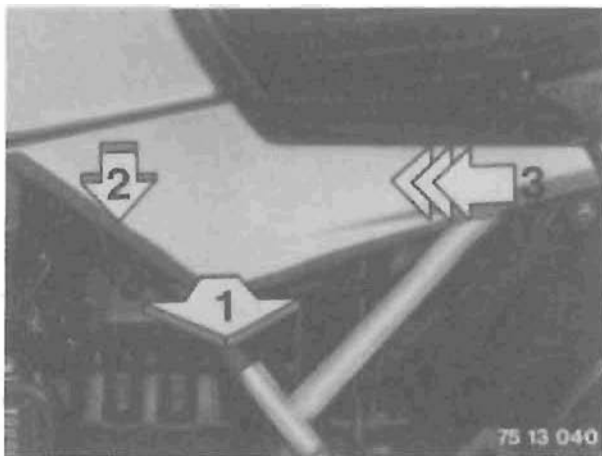

Fuel injection control unit – removing and installing

Take off the battery covers at left and right (see illustration).



- 1 = Carefully pull away from the frame at the base
- 2 = Press down to remove from holder (on fuel tank)
- 3 = Then pull forward and take off.

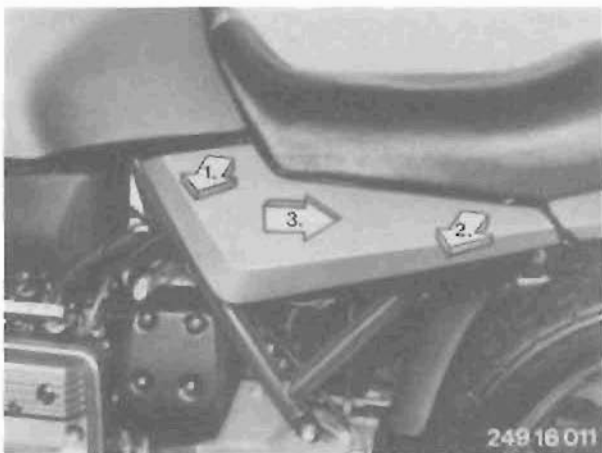

Fuel tank with bridge mounting

- 1 = Carefully pull away from frame.
- 2 = Carefully pull away from frame.
- 3 = Carefully pull back from arbor on frame.

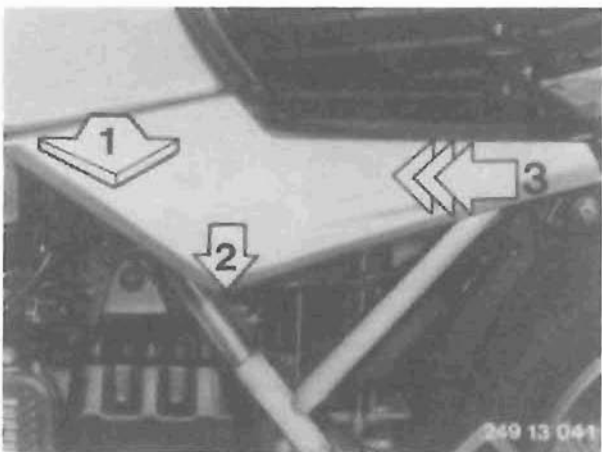

Fuel tank without bridge mounting

- 1 = Carefully pull away from frame.
- 2 = Carefully pull down slightly.
- 3 = Pull arbor out of dualseat frame to front.



Pull off the injection control unit cover in the direction of the arrow.

Push back the retaining hoop for the multi-pin plug in the direction of the arrow.

First pull off the multi-pin plug at the rear, then disengage it at the front.

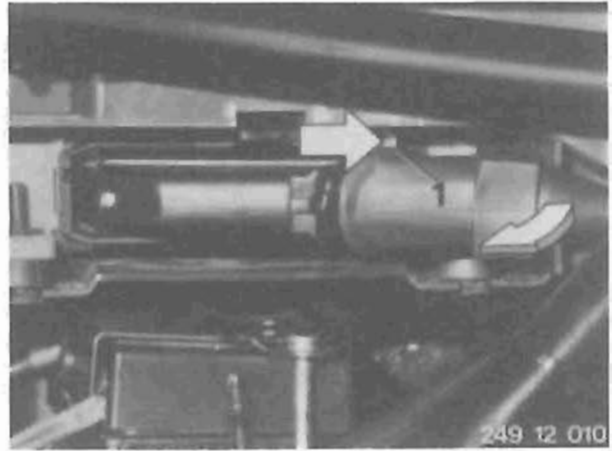

Pull off the keeper peg (arrow) for the control unit to the top, using flat pliers.

Pull the fuel injection control unit out of the storage tray to the left.

Install by following the same procedure but in the reverse sequence.

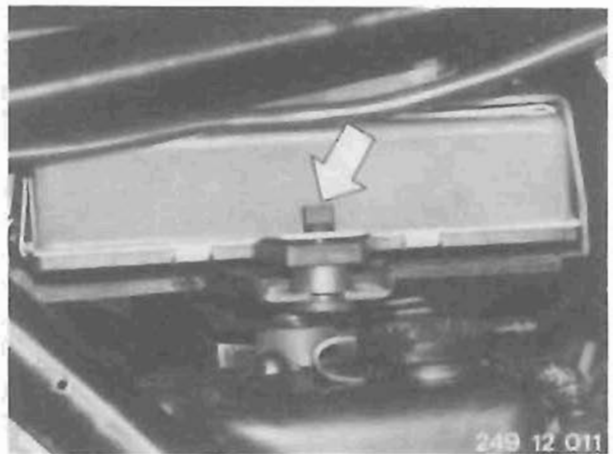

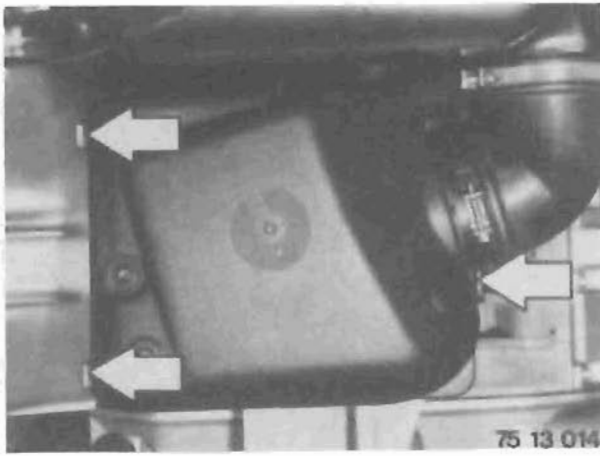

Air flowmeter – removing and installing



Pull intake tube off lower section of air cleaner housing and intake pipe.



K 100 RS, RT, LT: remove knee pad and lower right-hand fairing (see Group 46).

Pull intake tube off lower section of air cleaner housing and intake pipe.

Unscrew intake pipe on radiator.

Loosen hose connectors (1) on air line collector. (The picture was taken with the engine removed to provide a better illustration.)



Take out the upper section of the air cleaner housing. Remove retaining screws (arrows) on air flowmeter and loosen hose connectors (1) on air line.

Tightening torque:

Retaining screw

$6 \pm 1 \text{ Nm}$



Turn over the upper section of the air cleaner housing. Pull the air flowmeter out of the upper section of the air cleaner housing and pull off multi-pin plug (arrow).

Install following the same procedure but in the reverse sequence.

16

Fuel tank and lines

16 Fuel tank and lines

Specifications	Page	16-03.0
Diagrams		16-05.0
Fuel tank – removing and installing		16-07.0
Fuel pump – removing and installing		16-11.0
Fuel pump pressure – testing		16-13.0
Fuel filter – removing and installing		16-14.0
Fuel level sensor (lever sensor) – removing and installing		16-15.0

Fuel tank and lines
Specifications

Model		K 75	K 75 c	K 75 s	K 100	K 100 RS	K 100 RT	K 100 LT
Fuel tank								
Tank capacity	l	21			22			
Reserve included in above capacity	l	Visual warning signal at app. 5						
Fuel pump								
Type		Roller-cell pump						
Manufacturer		Bosch						
Operating voltage	V	12						
Pump pressure	bar	2.5						
Output	l/h	45						

Fuel system

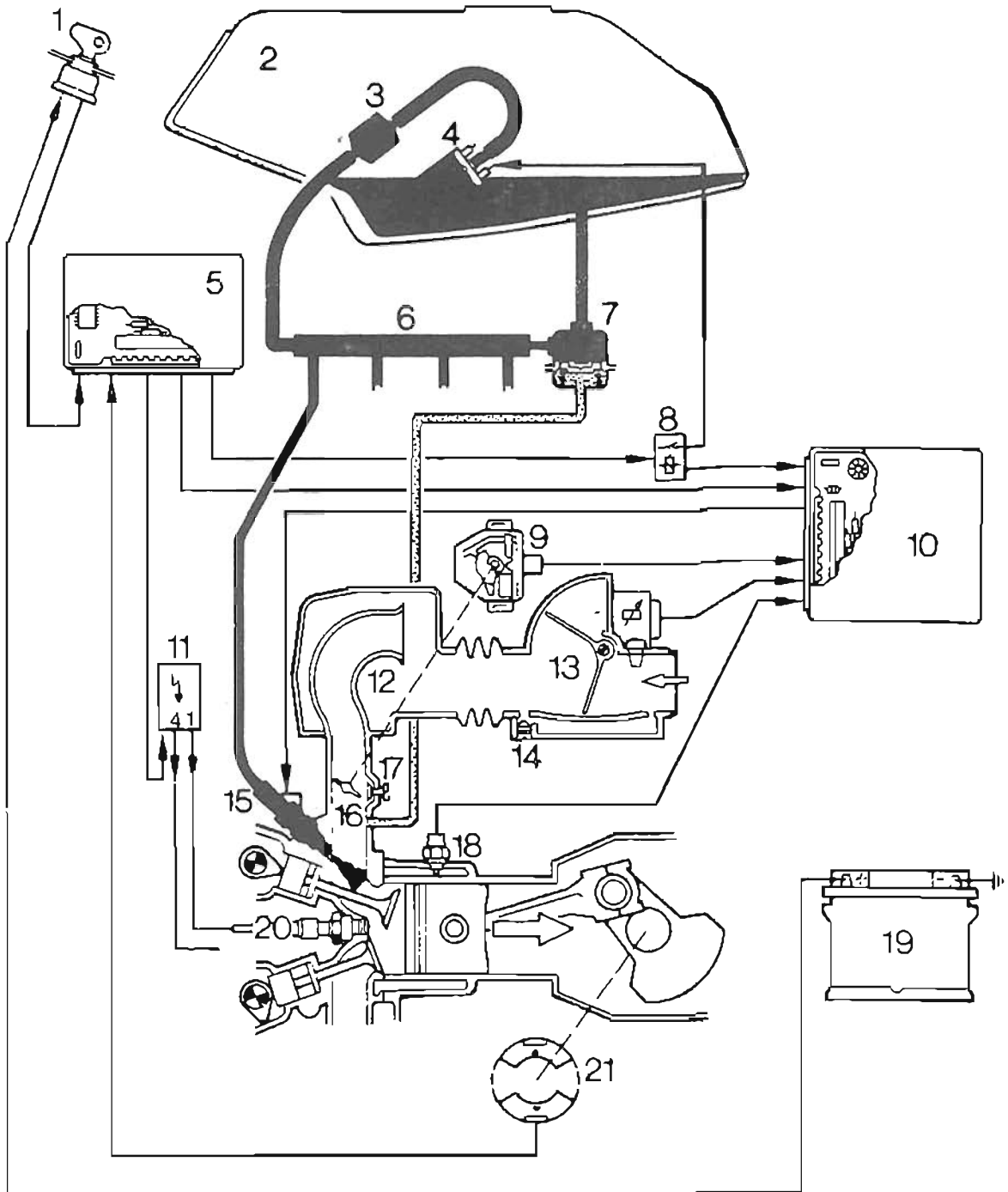

- 2 Fuel tank
- 3 Fuel filter
- 4 Fuel pump
- 6 Injector rail
- 7 Pressure regulator
- 15 Injector

Fuel tank layout

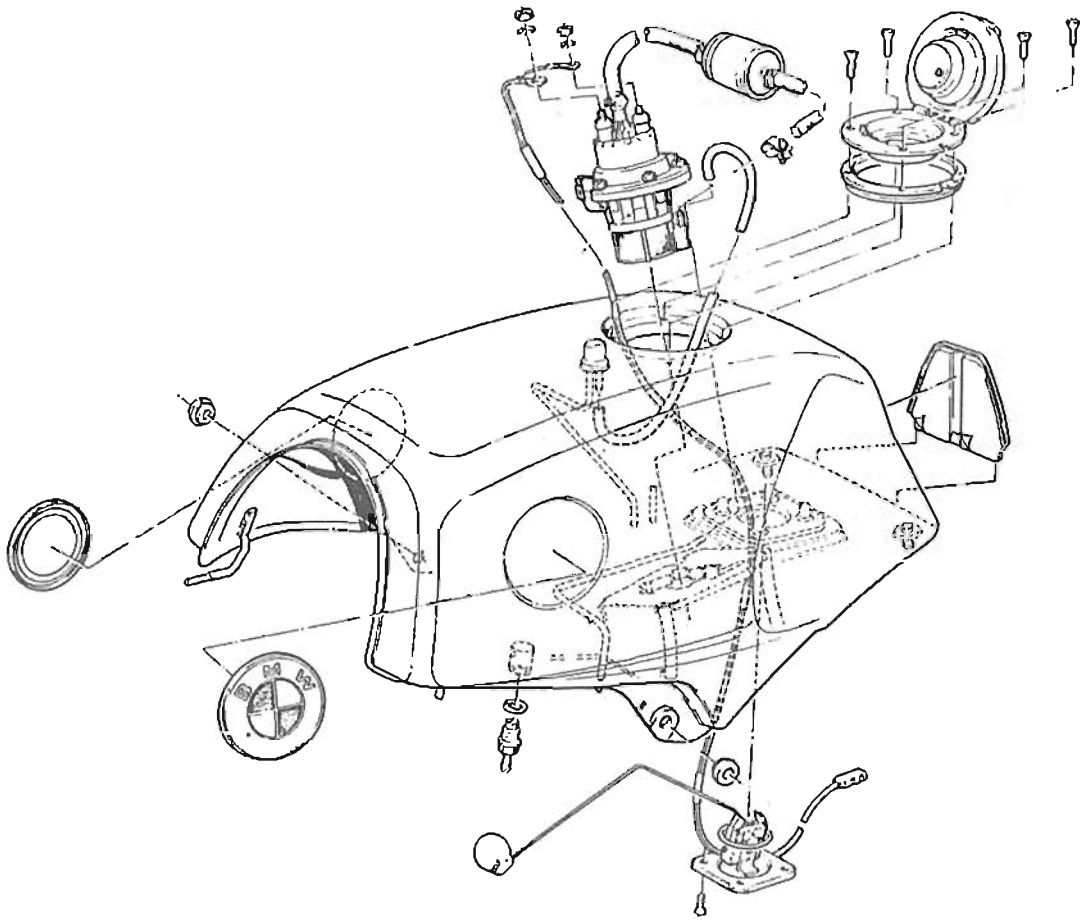

Fuel tank on frame

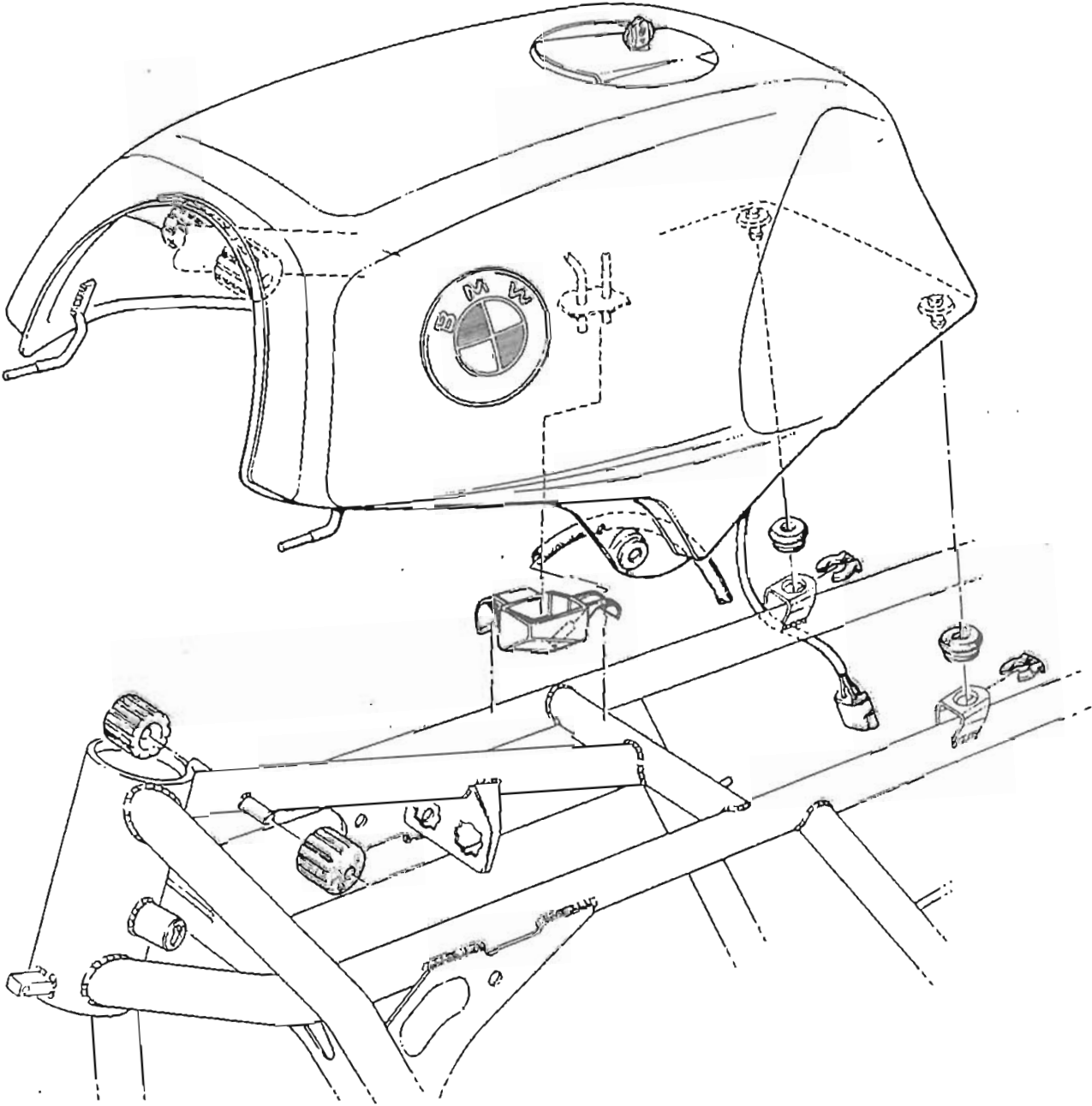

Fuel tank – removing and installing

Remove battery cover on both sides (see illustration).



- 1 = Carefully pull down from frame at base.
- 2 = Push down to remove from fixture (on fuel tank).
- 3 = Pull forward and remove.

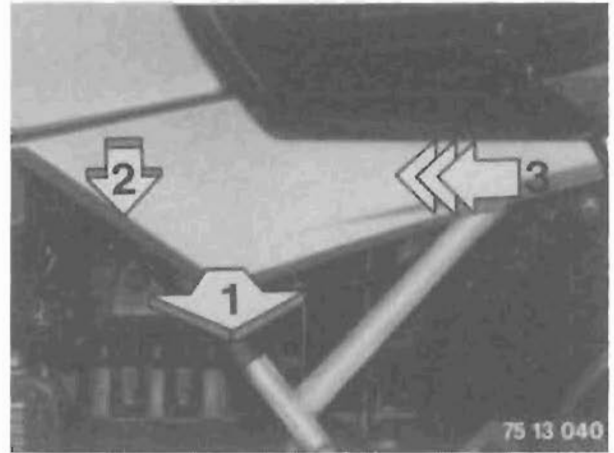

Fuel tank with bridge mounting

- 1 = Carefully pull off frame.
- 2 = Carefully pull off frame.
- 3 = Carefully pull back from arbor on frame.

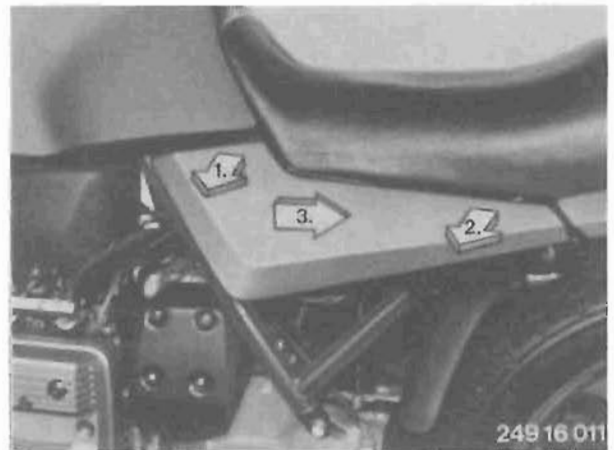

Fuel tank without bridge mounting

- 1 = Carefully pull off frame.
- 2 = Carefully pull down slightly.
- 3 = Pull arbor forward and out of dualseat frame.

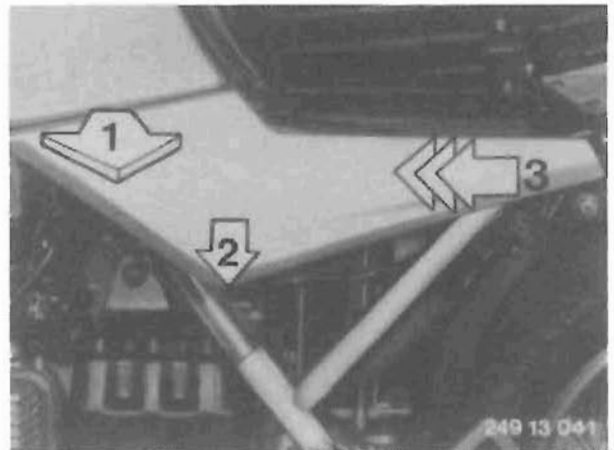

K 100 RT, LT: remove storage compartments.
K 100 RS, RT, LT: remove knee pads.

Fuel tank with bridge mounting.
K 100: pull radiator trim on either side out of rubber bushing (arrow) on fuel tank.



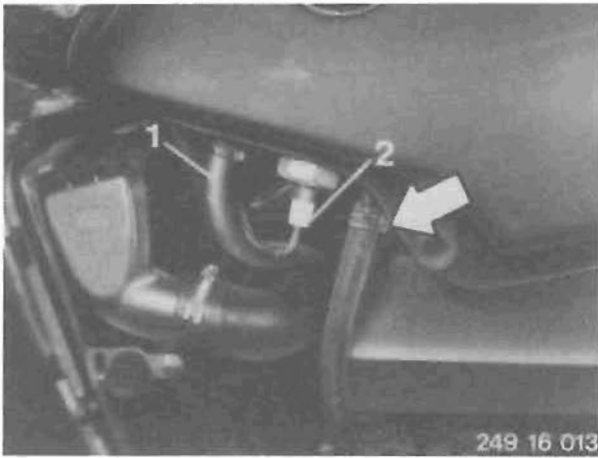

Loosen clip on return line (1) and pull off line. Pull off multi-pin plug (2) for fuel pump and transmitter for fuel gauge lamp. Loosen clip (arrow) for pressure line and pull off line. Since an amount of fuel always spills out of the pressure line, have a cloth ready.

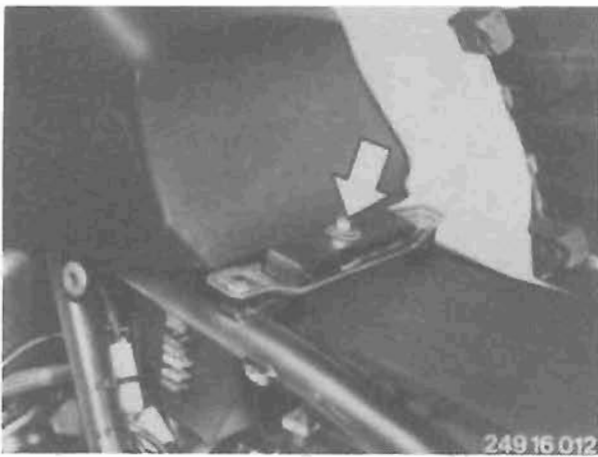

Release the retaining screw (arrow) on the bridge, push the fuel tank back a certain distance, lift up slightly and pull the breather hose off the tank base.

When installing:

Do not bend the breather line when fitting the fuel tank, or else the breather function will be rendered inoperative.

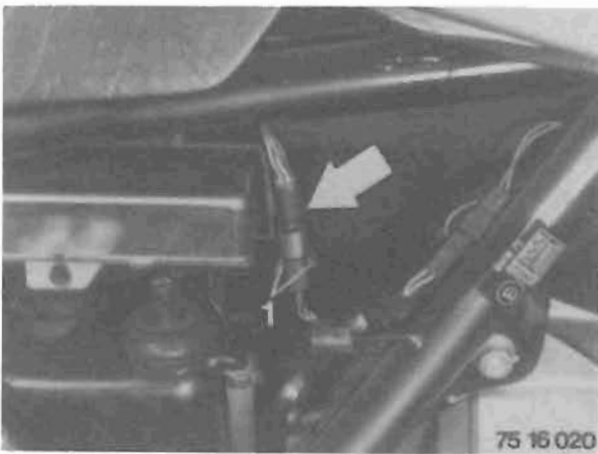

 and  Fuel tank without bridge mounting.

Disconnect fuel pump/fuel gauge line. Remove plug (arrow) from clip mounting. Push retaining clip (1) out and release the plug connection.

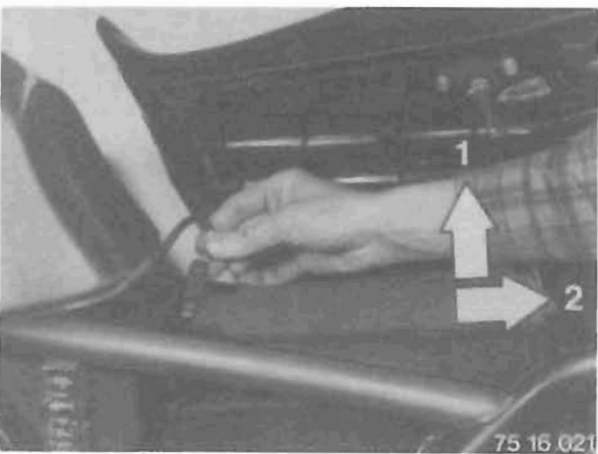

Open the dual seat.

Raise the tray (arrow 1) and pull back slightly (arrow 2). Pull up the fuel pump/fuel gauge line and remove.



K 75 c: carefully lever radiator trim out of rubber bushing on fuel tank on both sides with BMW lever 46 5 700.



Pull radiator trim a certain distance forward, lower and then take off to side.



Place cloth on injector rail to soak up seepage, as a certain amount of fuel will spill when the pressure line (1) is pulled off.

Detach fuel lines on fuel tank.

K 75 s: pull fuel line off injector rail.

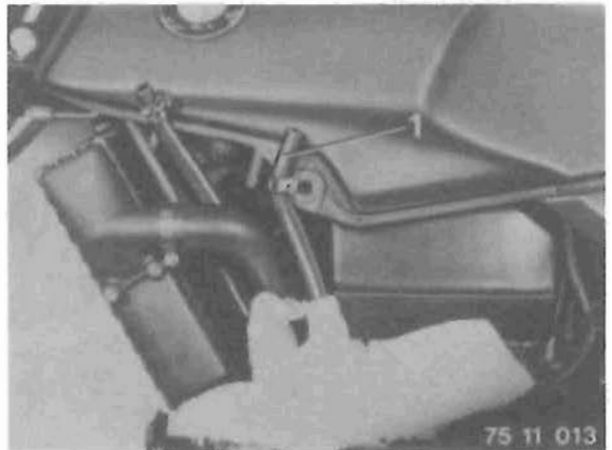

Pull off circlips for securing fuel tank with flat-nosed pliers.



Carefully lever the fuel tank out of the rubber bushings.

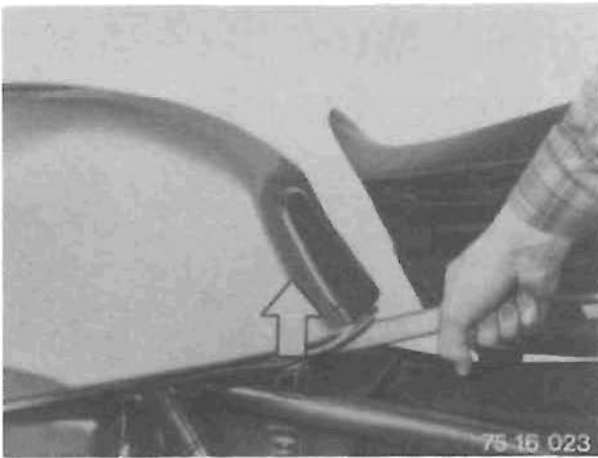

Place the fuel tank protective cover, BMW No. 16 1 600, on the fuel tank.

K 75 s: lift up the fuel tank at the front until the fuel return clip (arrow) is accessible. Release the clip (arrow) and lever off the hose.

Important:

To avoid damaging the paintwork, fit a plastic tube (1) over the screwdriver shaft.

Take off the fuel tank.

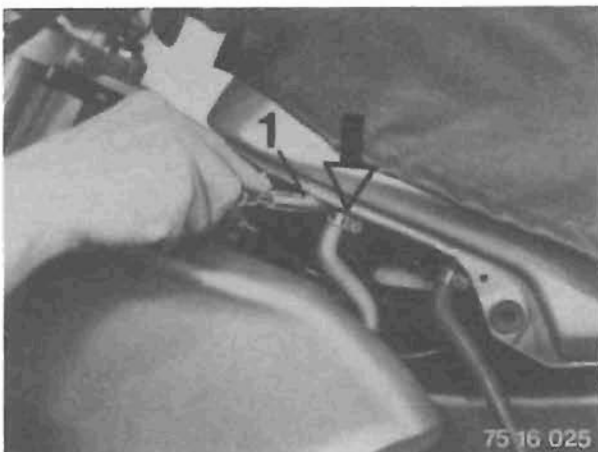

Install the fuel tank by following the same procedure but in the reverse sequence.

When installing:

Moisten the rubber rings (arrow), or coat them with tyre fitting paste, before installing the fuel tank in the rear mounting.

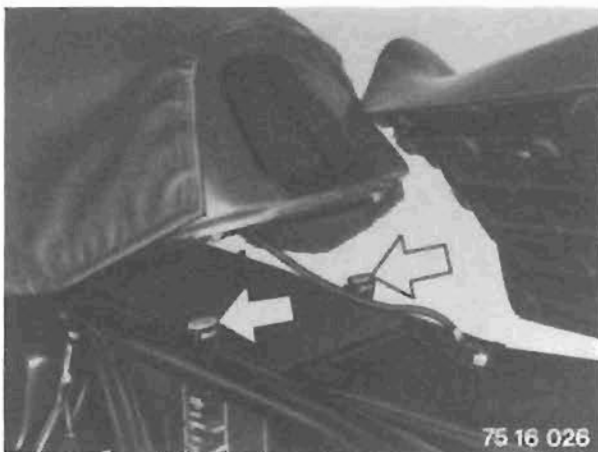

Fuel pump – removing and installing

Remove the retaining screws (arrows) for the fuel filler inlet and take it out.

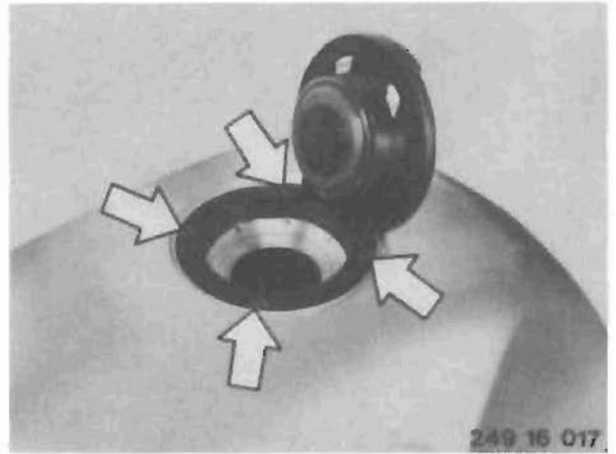

Disconnect the electrical connections and the fuel pressure line at the fuel pump (arrows).

Positive connection = M 4 nut
Negative connection = M 5 nut

The picture shows a sectioned model.

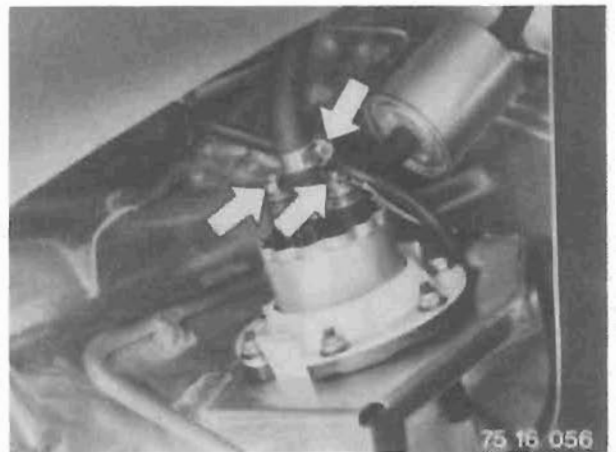

Squeeze the retaining clips (arrows) at the retaining ring firmly and pull out the fuel pump.

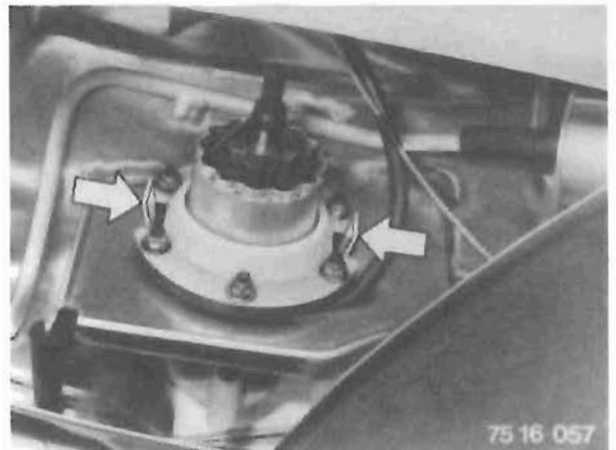

Pull the fuel filter off the fuel pump.

When installing:

Note the position of the arrow marks on the filter and vibration damper.

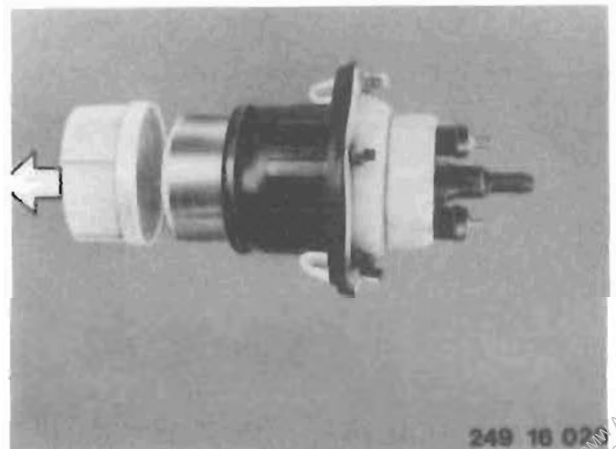

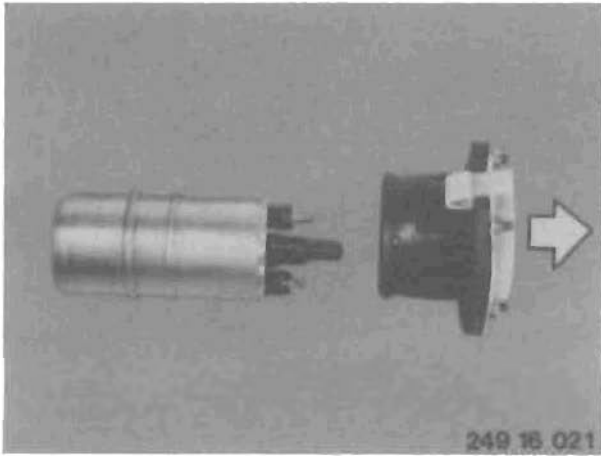

Pull the rubber-metal casing with retaining ring from the fuel pump.

When installing:

Push the rubber-metal casing on to the fuel pump until it is felt to engage.

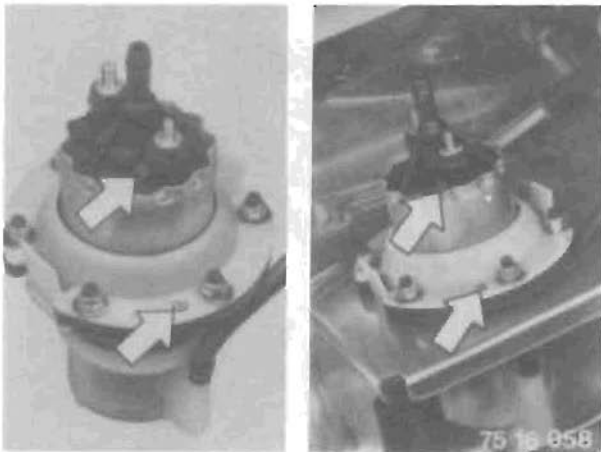

When installing:

The positive connection on the fuel pump (arrow) must be located opposite the plus mark (arrow) on the retaining ring.

Both marks must be located in the fuel tank on the left looking in the direction of travel.

Fuel pump pressure – testing



K 100 RT, LT: remove storage compartment on left
K 100 RS, RT, LT: remove knee pad on left.

Push BMW pressure test gauge 16 1 500 on to the left handlebar assembly.

Pull the fuel feed line off either the fuel tank or injector rail and connect the test pressure gauge between the two connections.

For correct pressure, see Specifications.

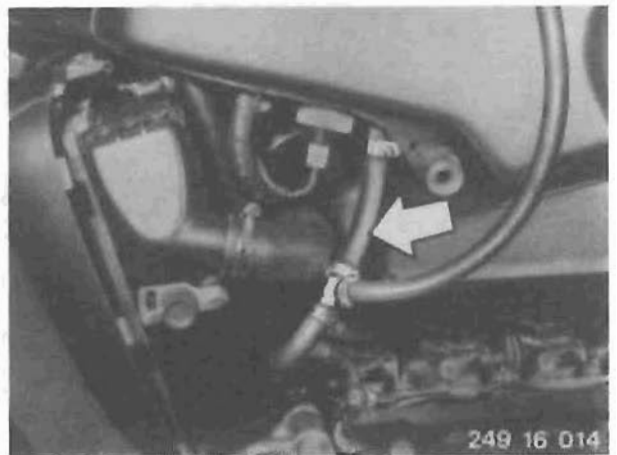
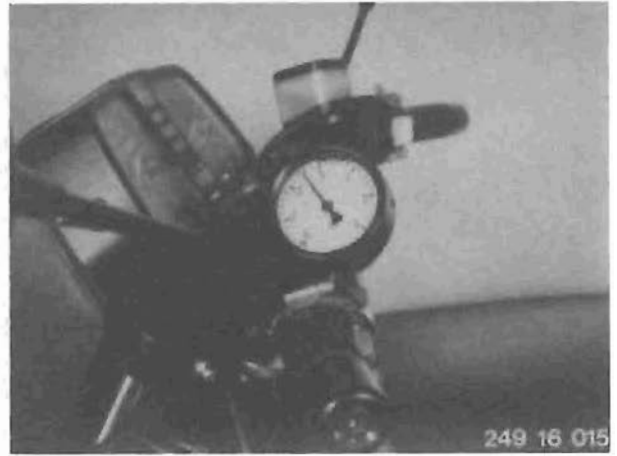

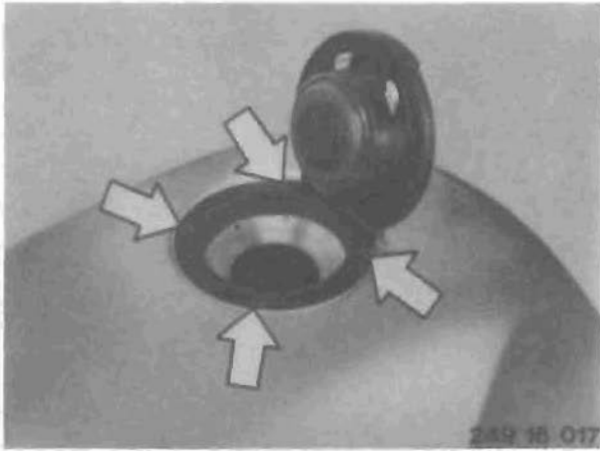

Fuel filter – removing and installing

Remove the retaining screws (arrow) for the fuel filler pipe and take it out.



Remove the hose union (arrow) at the pressure line. The picture shows a sectioned model.

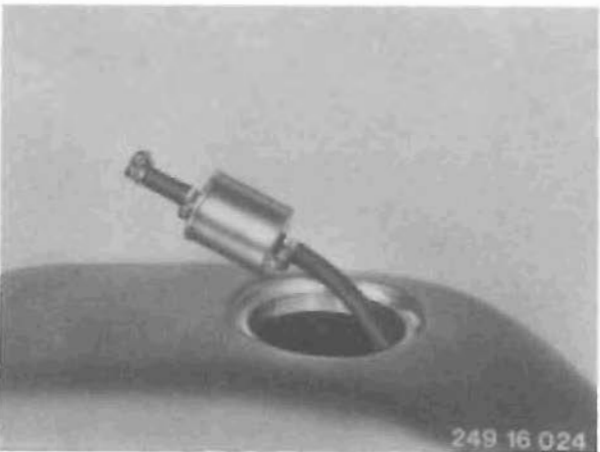

Pull the filter element with pressure line out of the filler pipe and set it down.
Remove the filter element.

When installing:

Note the correct fuel flow direction (see note on filter housing).

Fuel level sensor (lever sensor) – removing and installing

Empty the fuel tank.

Remove the fuel tank (see page 16–07.0).

Slacken off the fuel filler retaining screws (arrows) and take out the filler.

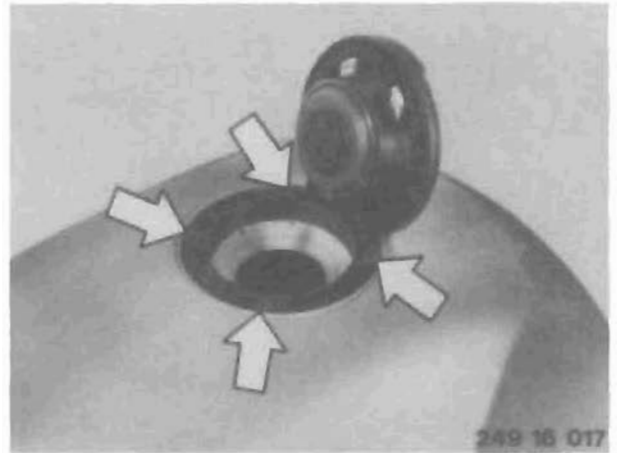

Disconnect the electrical connections for the fuel pump (arrow).

Positive connection = yellow cable, M 4 thread

Negative connection = black cable, M 5 thread

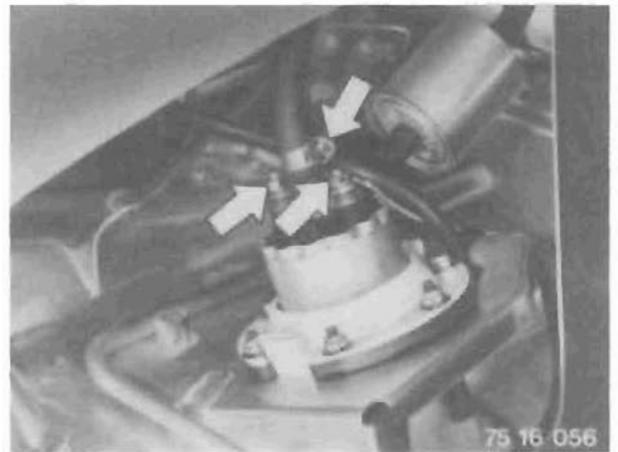

Release the base insulation from the underside of the fuel tank.

Slacken off the fuel level sensor retaining screws (1).

Take out the fuel level sensor with seal.

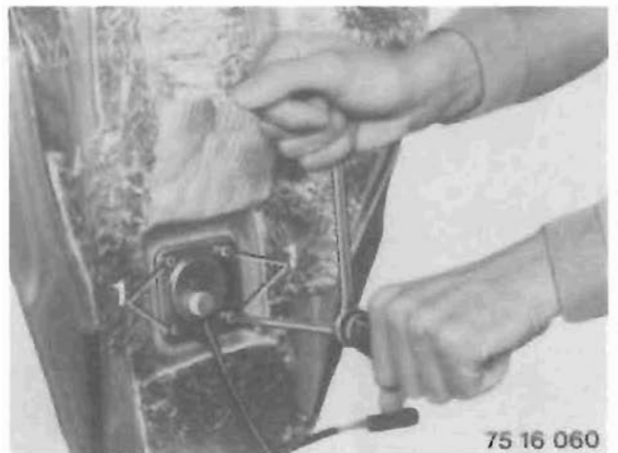

Install the fuel level sensor by following the same procedure but in the reverse sequence.

Check that the sealing ring (arrow) is correctly positioned.

Check free movement of the float lever after installing.

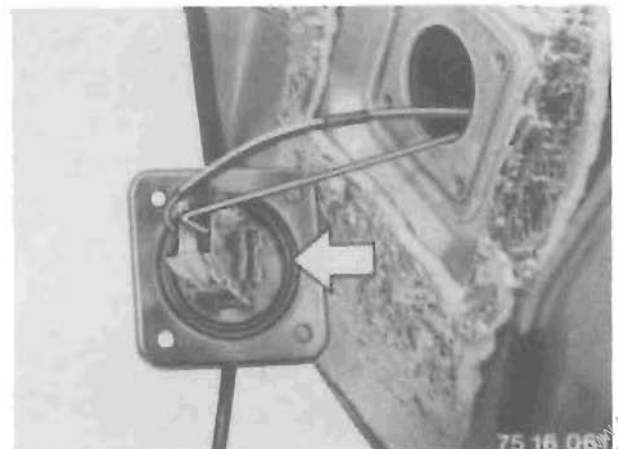

17

Radiator

17 Radiator

Specifications	Page 17-03.0
Tightening torques	17-05.0
Diagrams	17-07.0
Radiator – removing and installing	17-11.0
Fan motor – renewing	17-12.0
Filler cap – checking	17-12.0
Coolant – renewing	17-13.0
Thermostat – removing and installing	17-14.0

Radiator

Specifications

Model	K 75	K 75 c	K 75 s	K 100	K 100 RS	K 100 RT	K 100 LT
Radiator:							
Capacity	2.5 + 0.4 (in equalizing tank)			2.8 + 0.4 (in equalizing tank)			
Mixing ratio:							
Coolant: water	40 : 60 down to – 28°C 50 : 50 down to – 36°C						
Approved coolant:	Fricotin Antifreeze 007 ICI Glycoshell P 300 Glysantin G04 Genantin VP 17 19 ICI 012 Glysantin G 41/23						
Thermostat insert:							
Starts to open at:	°C	85					
Fan:							
Cuts in at:	°C	103					
Coolant temperature							
Warning lights comes on at:	°C	111					
Coolant filler cap							
Excess pressure							
valve opens at	bar	1.0 _{+0,15}					
– equivalent to	°C	120					
Negative pressure							
valve opens at	bar	–0.1 (in cooling-down phase)					

Radiator**Tightening torques**

Connection	Nm
Radiator to frame	8.5 ± 1
Thermostat housing	3.0 ± 0.45

Coolant circuit

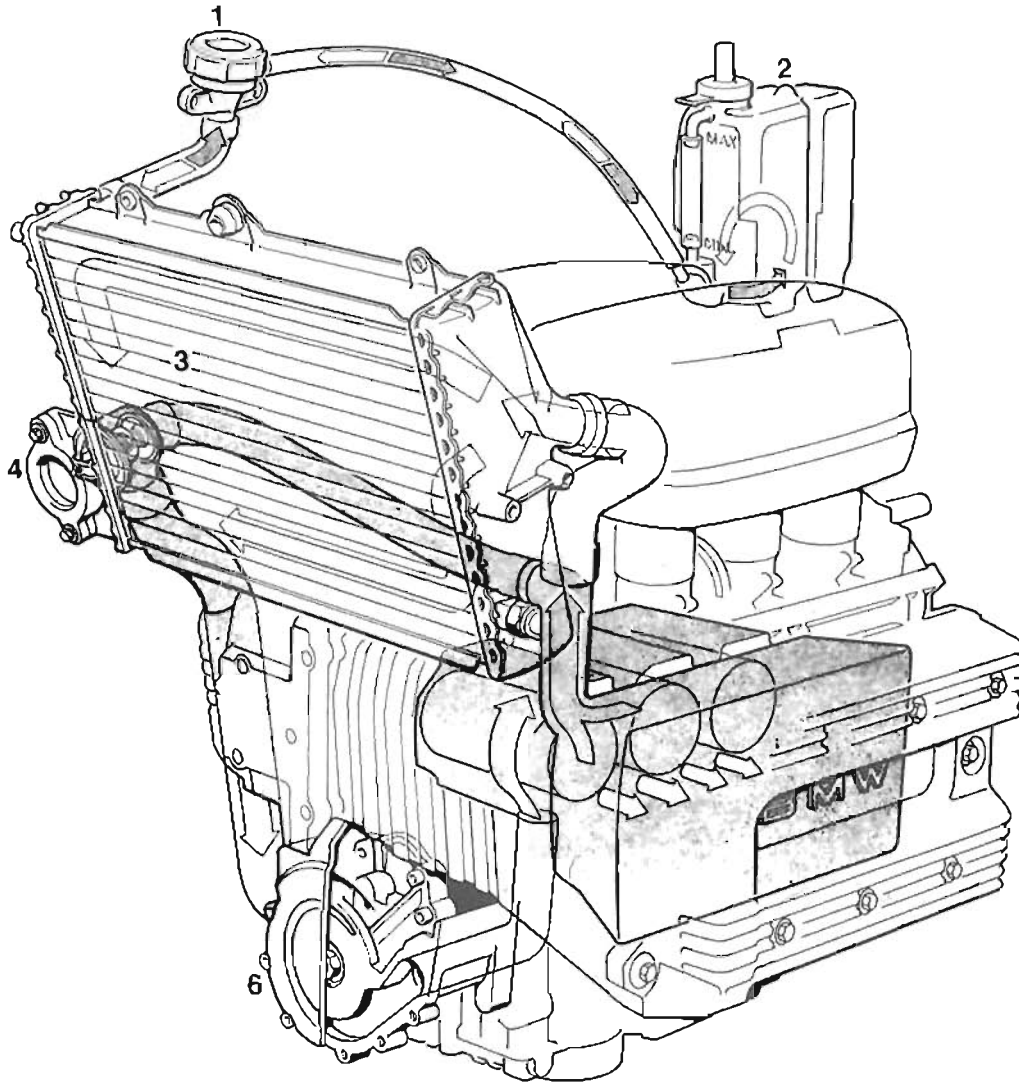

- 1 Radiator cap
- 2 Equalizing tank
- 3 Cross-flow radiator
- 4 Thermostat valve
- 5 Temperature sensor
- 6 Water pump

Radiator

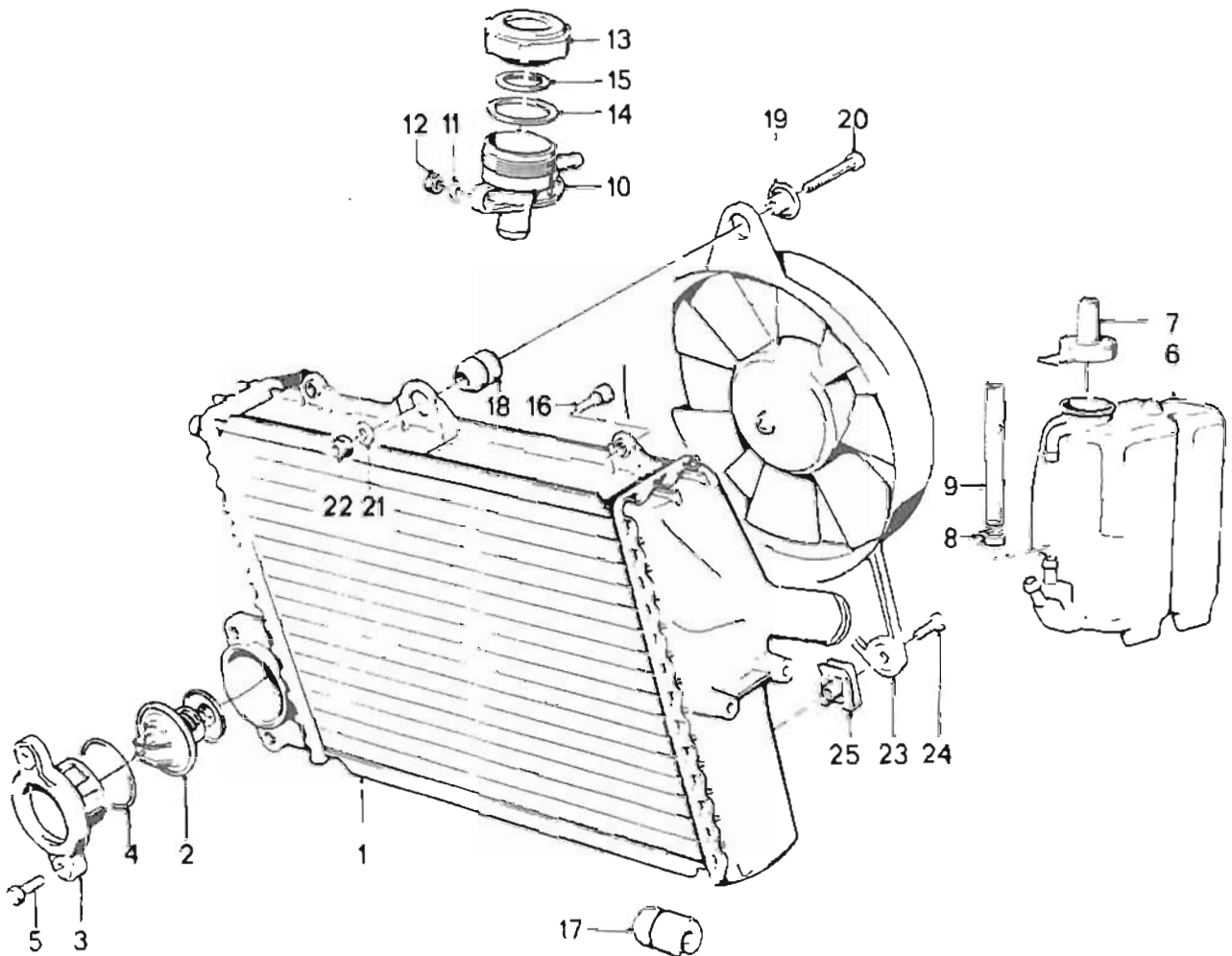

- | | |
|-------------------|----------------------|
| 1 Radiator | 14 Sealing ring |
| 2 Thermostat | 15 Sealing ring |
| 3 Cover | 16 Buffer |
| 4 O-ring | 17 Support |
| 5 Hex bolt | 18 Rubber bushing |
| 6 Equalizing tank | 19 Spacer sleeve |
| 7 Cap | 20 Machine screw |
| 8 Hose clip | 21 Spacer |
| 9 Hose | 22 Hex nut |
| 10 Filler inlet | 23 Fan |
| 11 Spacer | 24 Countersunk screw |
| 12 Hex nut | 25 Sheet-metal nut |
| 13 Cap | |

Radiator – removing and installing

Remove fuel tank (see page 16–07.0)

K 75 s: remove fairing (see Group 46).

Remove radiator fairing (see Group 46).

K 100 RT, LT: remove storage compartments (see Group 46)

K 100 RS, RT, LT: remove knee pads and lower fairing sections.

Remove radiator fairing.

Slacken off the drain screw (arrow) and drain off the coolant.

Note:

Slacken off the filler cap to drain the system more quickly.

Release the hose clip (1) on the top right of the radiator and pull off the hose.

Pull out the air intake line from the bottom section of the air cleaner housing and pull it off the intake stub.

Slacken off the intake stub retaining screws at the radiator and take off the stub.

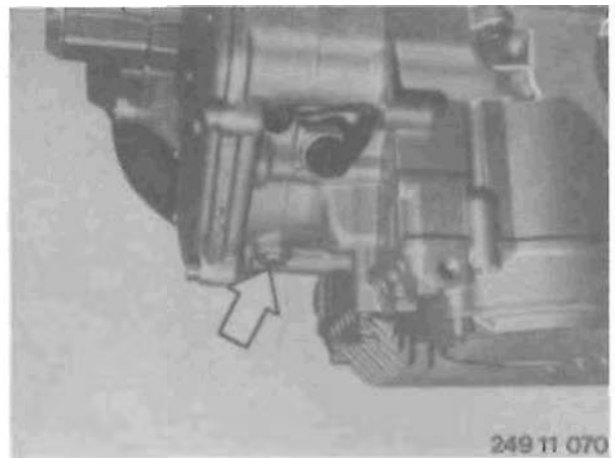

Release the hose clips (arrows) at the thermostat housing and pull off the hoses.

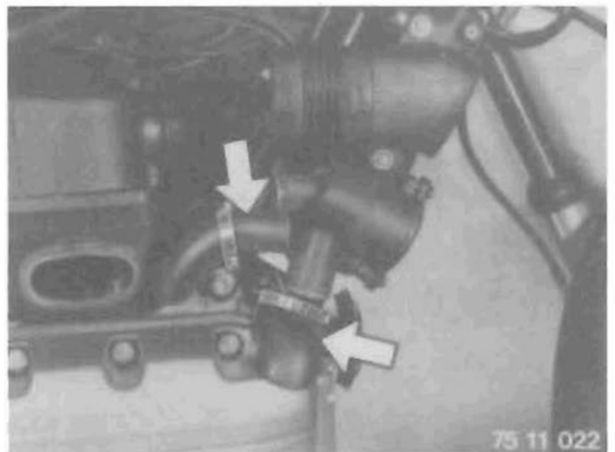

Release the hose clip (arrow) at the radiator and pull off the hose.



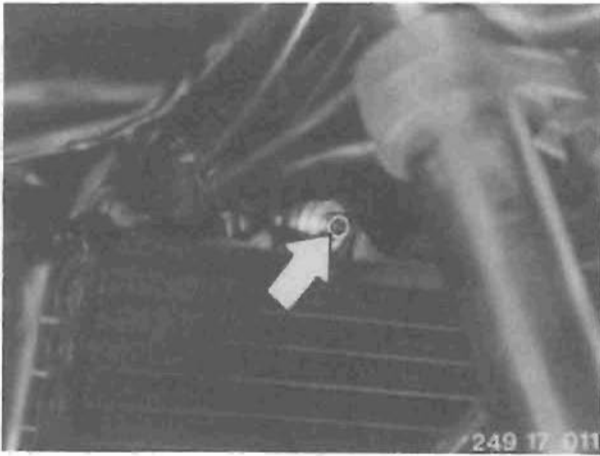

Slacken off the radiator retaining screw (arrow) at the frame.

Tip the radiator forwards at the top.

Separate the plug connection on the fan motor and take off the radiator to the front.

Install by following the same procedure but in the reverse sequence.

Fan motor – renewing

Slacken off the fan motor retaining screws (arrows) at the radiator and take off the motor.

Install by following the same procedure but in the reverse sequence.

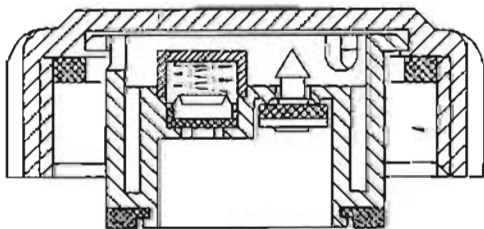

Filler cap – checking

Check operation of the pressure relief valve in the filler cap with BMW tester 17 0 500 and the intermediate piece/ threaded union.

Attach intermediate section to the tester with clips, screw the threaded pipe on to the intermediate section and then the filler cap on to the threaded pipe.

Pump up the system.

Pressure relief valve must open at $1.0 + 0.15$ bar.

Note:

Note the seals.

75 17001

Coolant – renewing

Remove fuel tank (see page 16–07.0)

Slacken off the drain screw (arrow) and drain off the coolant.

Note:

Slacken off the filler cap to drain the system more quickly.

Tighten the drain screw with a new sealing ring.

Tightening torque:

Drain screw: $9 \pm 1 \text{ Nm}$

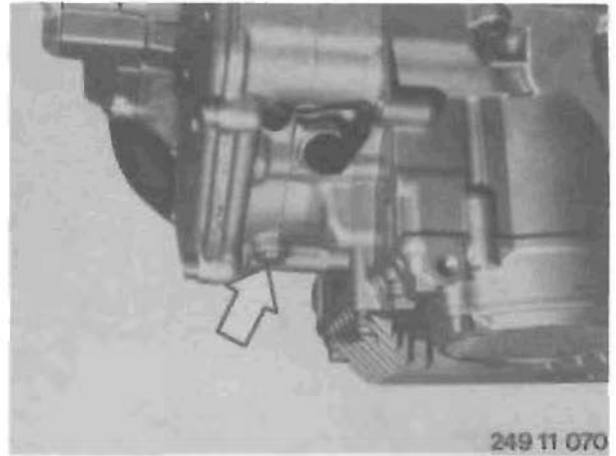



Add coolant at the filler pipe.

Note:

Use approved grades of antifreeze only (see Specifications, see page 17–03.0).

Capacity:

 2,5l + 0,4 l in the equalizing tank.

 2,8l + 0,4 l in the equalizing tank.



Add coolant at the filler pipe up to the bottom edge of the overflow (arrow).

Note:

To bleed the cooling system, turn the over engine with the starter motor and "knead" the coolant hose between the water pump and thermostat housing at the same time.

Top up with coolant if necessary.

Screw the cap with seal on to the filler pipe.

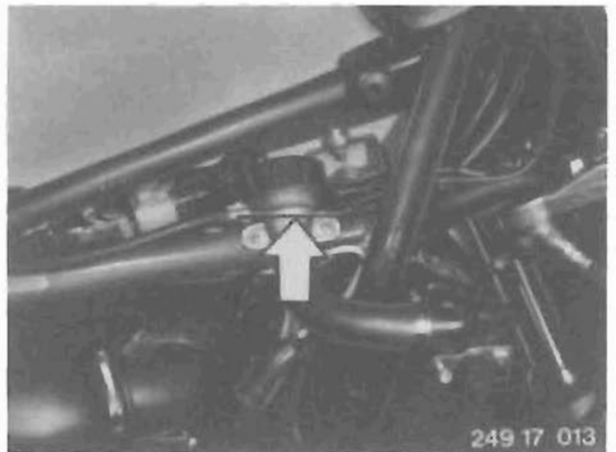

The equalizing tank must be filled to between the "MAX" and "MIN" marks.

Note:

Never fill beyond "MAX".

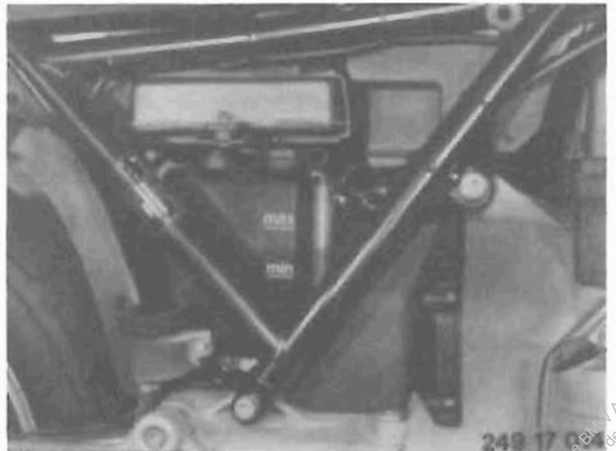

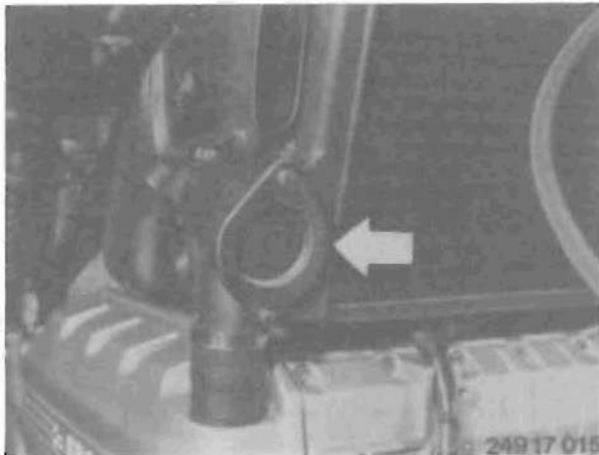

Thermostat – removing and installing



K 75 s: remove right-hand fairing (see Group 46).



K 100 RS: remove right-hand lower fairing section (see Group 46).

Remove fairing (see Group 46).

Remove fuel tank (see Group 16).

Drain off the coolant (see page 17–13.0).

Slacken off the retaining screws for the thermostat housing cover (arrow) and take off the cover.

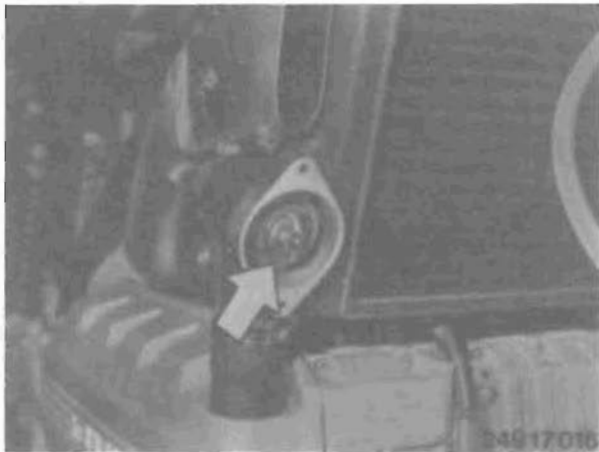

Pull the thermostat (arrow) out of the housing.

See illustration for correct installed position.

Heat the thermostat in water and check compliance with the temperatures given in the Specification for start of opening (app. 85°C) and fully open (app. 92°C). Renew the thermostat if necessary.

Install by following the same procedure but in the reverse sequence.

18

Exhaust system

18 Exhaust system

Specifications	Page 18-03.0
Tightening torques	18-03.0
Complete exhaust system – removing and installing	18-05.0
Exhaust pipes – removing and installing	18-05.0
Silencers – removing and installing	18-05.0
Shield panel – renewing	18-06.0

Complete exhaust system – removing and installing

Slacken off the nuts (arrows) for the exhaust system at the cylinder head.

Note:

Use the sealing rings once only.

Tightening torque:

Nuts on cylinder head $21 \pm 2 \text{ Nm}$

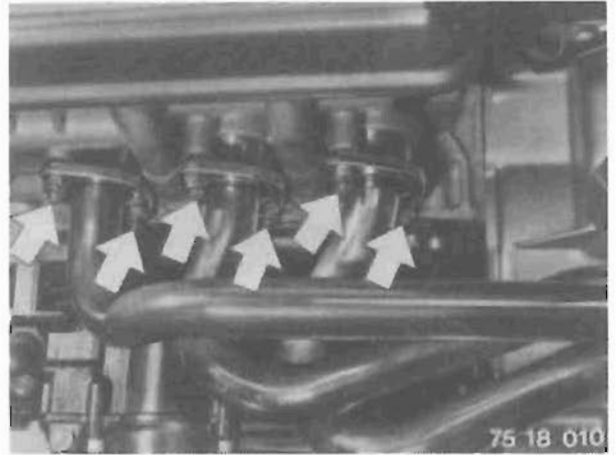

Slacken off the footrest plate retaining screws and take off the complete exhaust system.

Tightening torque:

Retaining screw $9 \pm 1 \text{ Nm}$

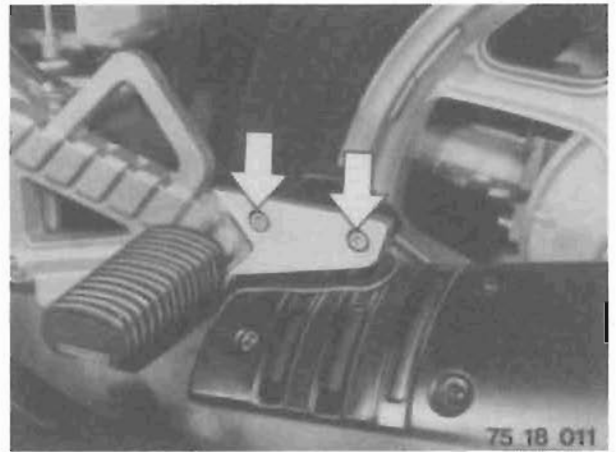

Silencer – removing and installing



Slacken off the retaining screws on the footrest plate (see above).

Tightening torque:

Retaining clip $20.5 \pm 2 \text{ Nm}$

Release the retaining clip on the silencer.

Pull off silencer.

Note:

Use the seal once only.

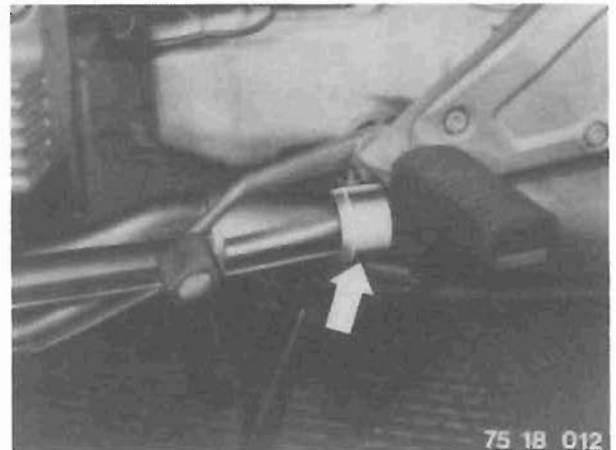

Remove shield panel on silencer (see page 18–06.0).

Slacken off retaining screws on footrest plate (see above).

Loosen four retaining clips on silencer.

Pull off the silencer.

Tightening torque:

Retaining clip $20.5 \pm 2 \text{ Nm}$

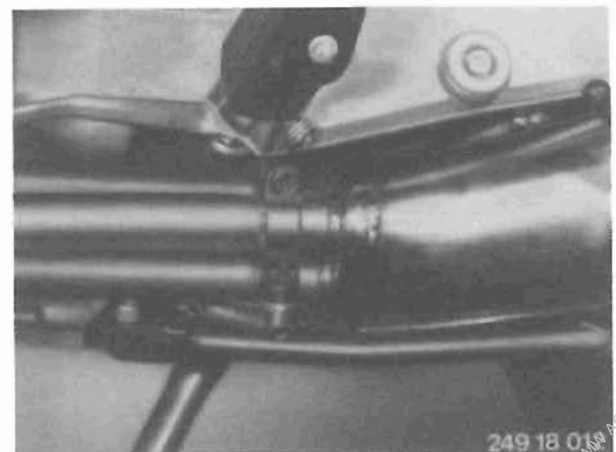

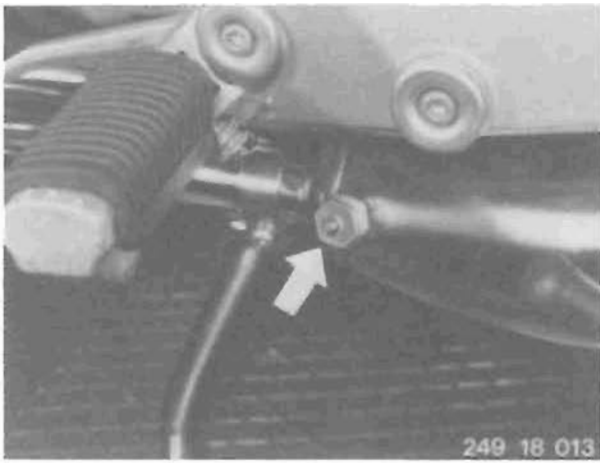

Shield panel on silencer – removing and installing



Slacken off the retaining screws for the shield panel at the silencer and take off the shield panel.



Slacken off the retaining screws for the shield panel at the silencer and take off the shield panel.

Note:

When slackening off and tightening the front retaining nut for the shield panel, it is essential to prevent the hex (arrow) on the vibration-proof mounting from turning with an open-ended wrench, as the mounting could otherwise split.

Picture shows the shield panel dismantled to provide a better illustration.

Tightening torque:

Retaining screw

$6 \pm 1 \text{ Nm}$

21

Clutch



21 Clutch

Specifications	Page 21-03.0
Tightening torques	21-04.0
Diagrams	21-05.0
Clutch – removing	21-07.0
Clutch housing – removing	21-07.0
Clutch housing – installing	21-08.0
Clutch – installing	21-08.0
Clutch operating clearance – basic setting	21-09.0
Clutch thrust bearing – removing	21-10.0
Clutch thrust rod – removing	21-11.0
Output shaft sealing ring – removing and installing	21-11.0
Clutch thrust rod – installing	21-11.0
Clutch thrust bearing – installing	21-11.0

Clutch**Specifications**

Model	K 75	K 75 c	K 75 s	K 100	K 100 RS	K 100 RT	K 100 LT
Type of clutch	Single dry plate with step-up diaphragm spring						
Extl. dia. of clutch plate	mm			165 ± 1		180 ± 1	
Total thickness of clutch plate (with lining)	mm		5.3 ± 0.25				
Min. thickness of clutch plate	mm		4.5				
Free travel at handlebar lever	mm		2.0 + 0.5		4.0 + 0.5		
Length of cable at withdrawal arm	mm		75 ± 1				

Clutch**Tightening torques**

Connection	Nm
Clutch flange to output shaft	
	140 + 5
	140 ± 5, then release and tighten again to 100 ⁺¹⁴ ₋₁₀
Housing cover to clutch housing	19 ± 2

Clutch

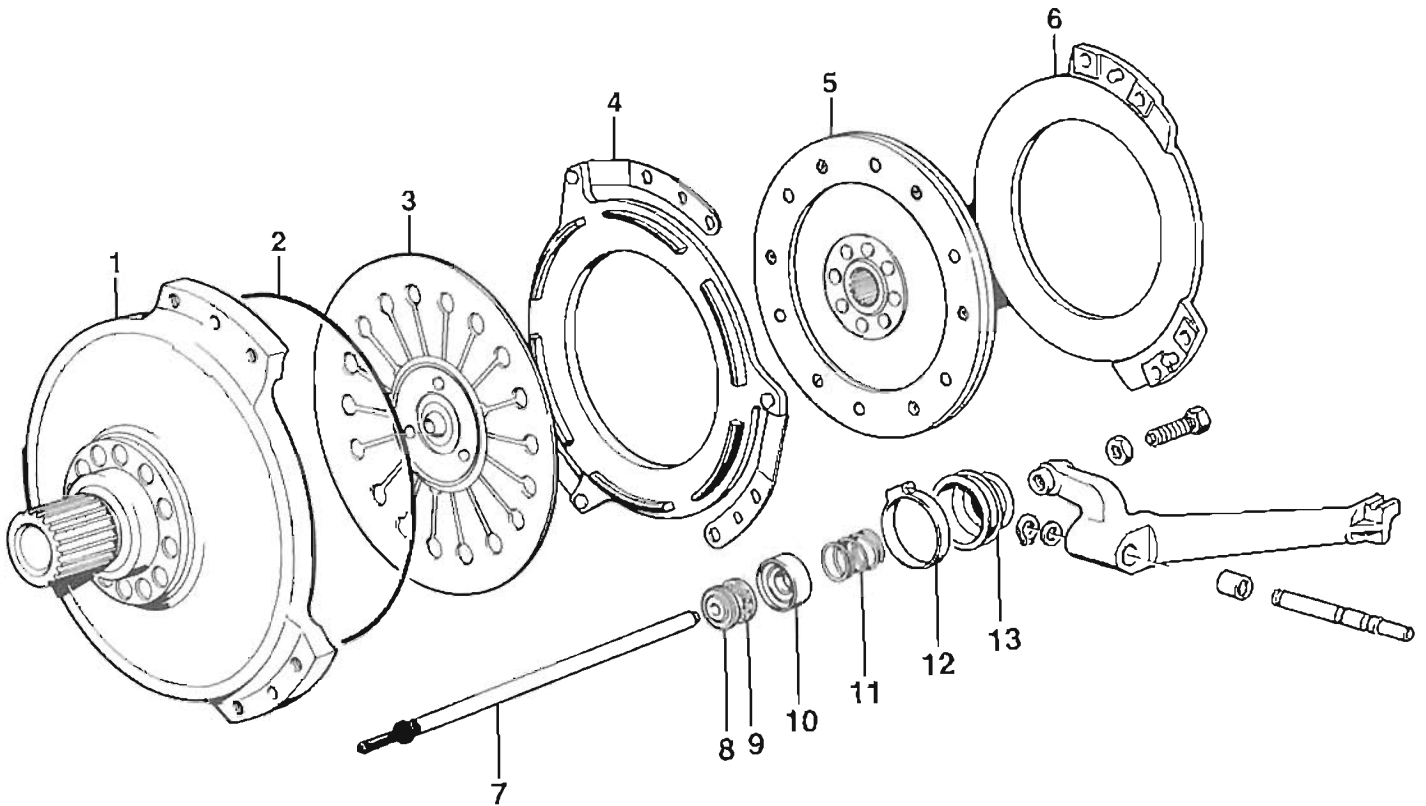

- 1 Clutch housing
- 2 Wire ring
- 3 Diaphragm spring
- 4 Pressure plate
- 5 Clutch plate
- 6 Housing cover

- 7 Thrustrod
- 8 Bearing reaction ring
- 9 Ball bearing
- 10 Thrust piston
- 11 Spring
- 12 Clamp
- 13 Sleeve

Lubricating points

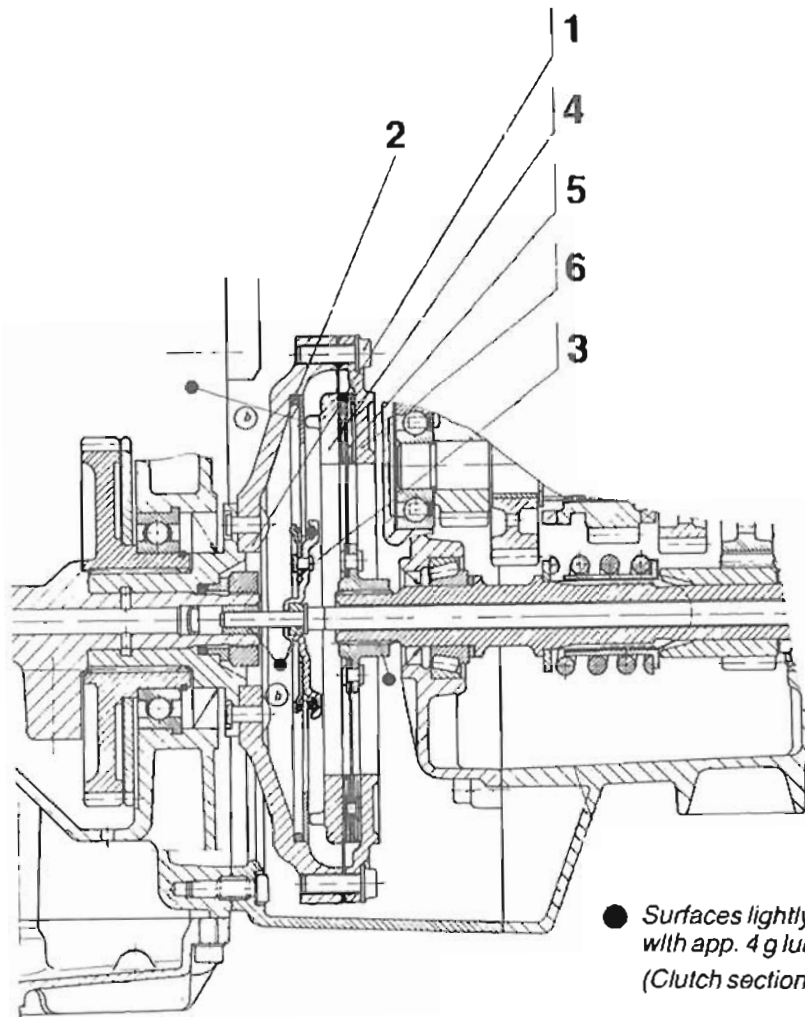

- 1 Clutch housing
- 2 Circlip
- 3 Diaphragm spring
- 4 Pressure plate
- 5 Clutch plate
- 6 Housing cover

Table of approved lubricants:

Lubricating paste	OPTIMOLY PASTE PL	4 g
Lubricating agent	STABURAGS NBU 30 PTM	4 g

Acheson lubricating mixture:

Lubricating agent	ACHESON	0,6 g
Thinner	SOLVETANE	3,4 g

Clutch – removing

The engine has been removed here to provide a better illustration.

Remove gearbox (see Group 23).

Slacken off the retaining screws (arrows) for the housing cover.

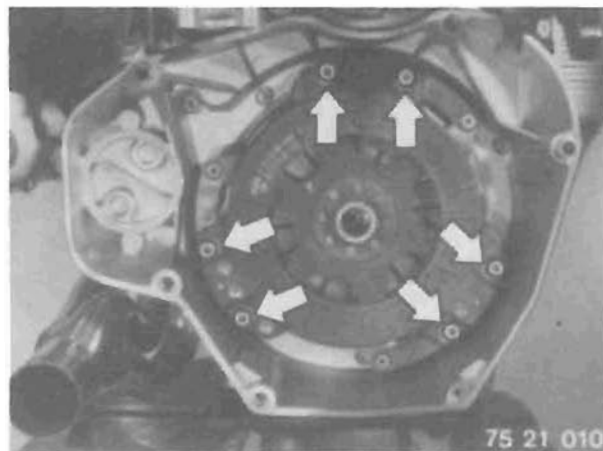

Take out the housing cover (1), clutch plate (2), pressure plate (3) and diaphragm spring (4)
Take out the wire ring.

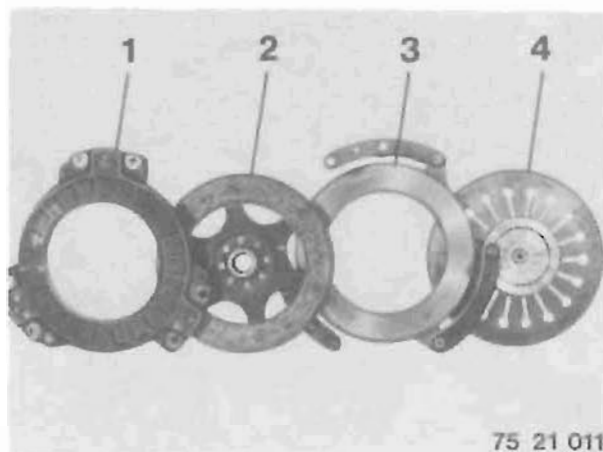

Clutch housing – removing

Attach BMW holder 11 2 800 in the position illustrated.

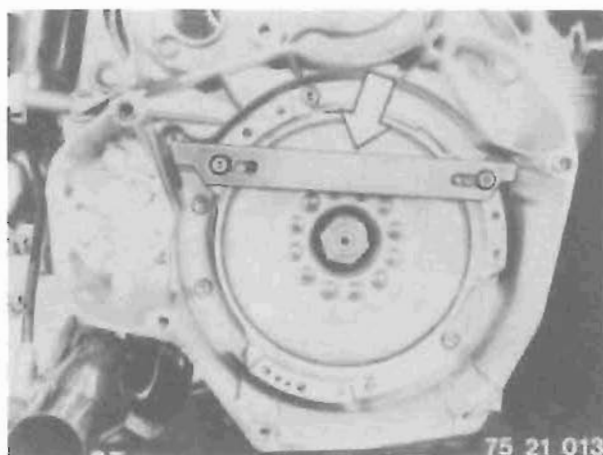

Unscrew and remove the hex nut.
Take out the thrust washer (arrow).
Move the clutch housing to and fro until the O-ring becomes visible. Cut through the O-ring with a knife and take it out.
Pull off the clutch housing.

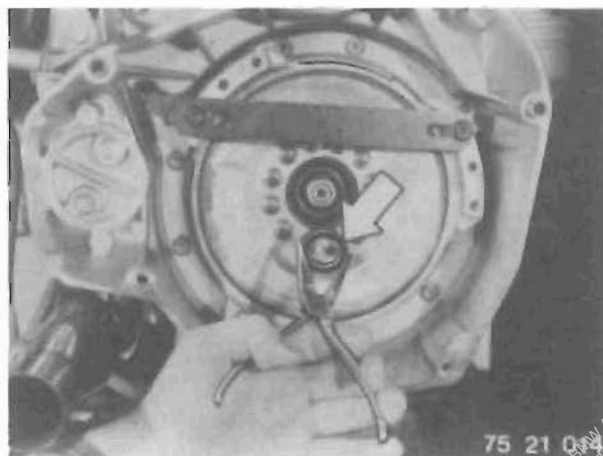

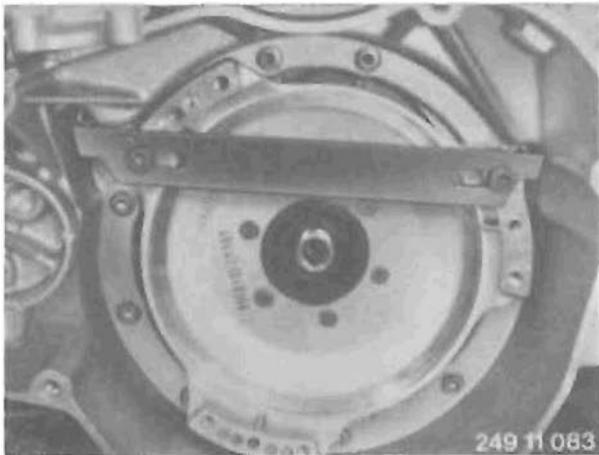

Clutch housing installing

Attach clutch housing with BMW holder 11 2 800 in the position illustrated.
Insert the new O-ring.

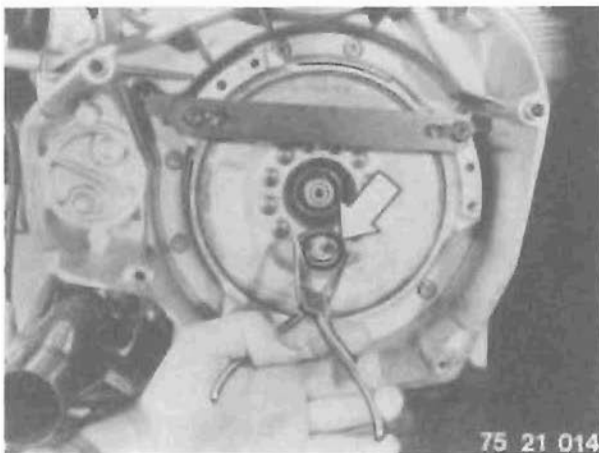

Fit the thrust washer (arrow) and tighten the hex nut.

Tightening torque:



Hex nut

$140 \pm 5 \text{ Nm}$



Hex nut

$140 \pm 5 \text{ Nm}$

then release and tighten again to $100 \begin{matrix} +14 \\ -10 \end{matrix} \text{ Nm}$

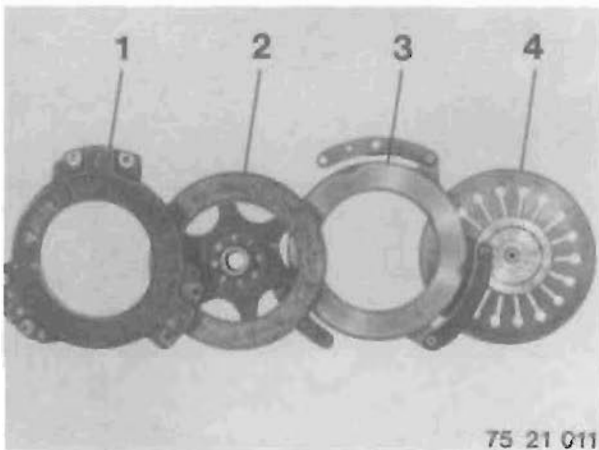

Clutch – installing

For lubricating chart, see diagrams, page 21 – 06.0.

Insert the wire ring and diaphragm spring (4) in the clutch housing.

Insert the pressure plate (3), clutch plate (2) and housing cover (1) in such a way that the colour marks are offset by app. 120° .

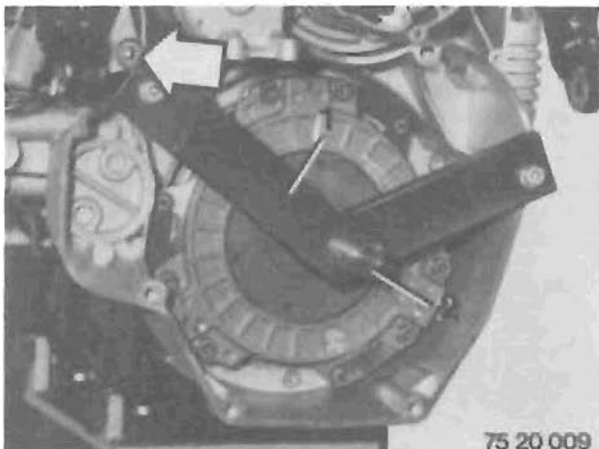

Centre the clutch plate with centering tool BMW No. 21 2 670.

Slacken off the lower retaining screw (arrow) on the ignition coil mounting.

Secure the centering bridge (1) to the intermediate flange as illustrated.

Centre the clutch with centering arbor (2).

Screw in the housing cover retaining bolts uniformly in a crosswise pattern and secure the housing cover.

Tightening torque:
Retaining screws

$19 \pm 2 \text{ Nm}$

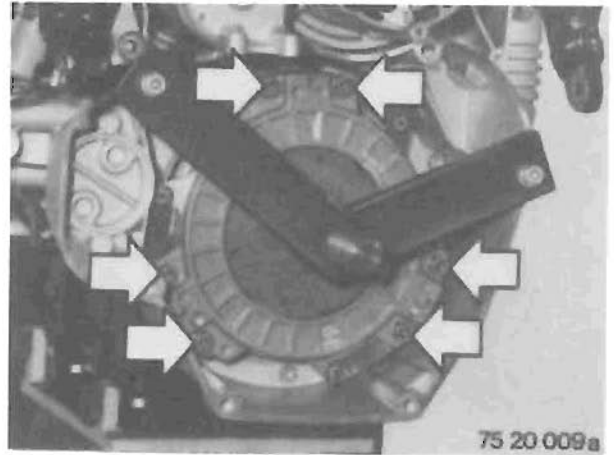

Clutch operating clearance – adjusting

Disconnect the clutch cable at the withdrawal arm (arrow).

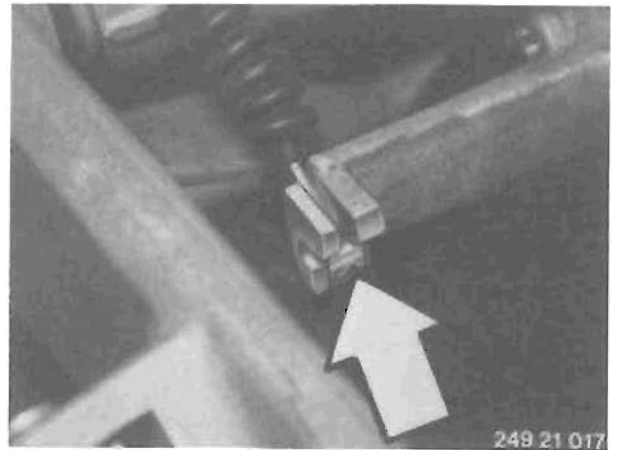

Basic setting:

Push the rubber gaiter (1) back slightly and adjust dimension B = $75 \pm 1 \text{ mm}$ with the adjuster at the clutch lever using BMW adjusting gauge 21 3 500 (see illustration below).

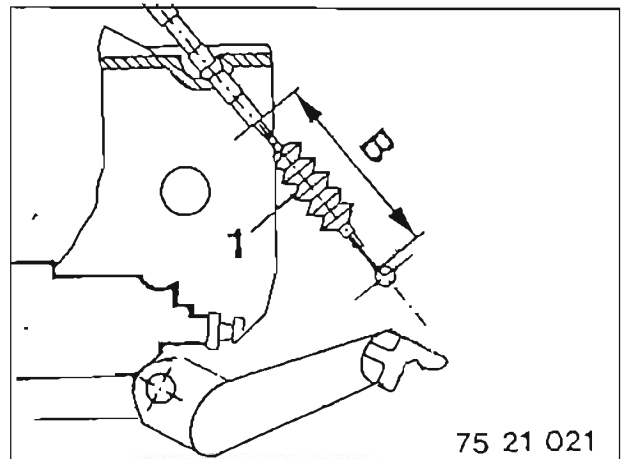

Loosen the knurled adjusting nut (1) at the clutch lever and turn adjusting screw (2) until dimension B is attained. Re-attach the clutch cable to the withdrawal arm.

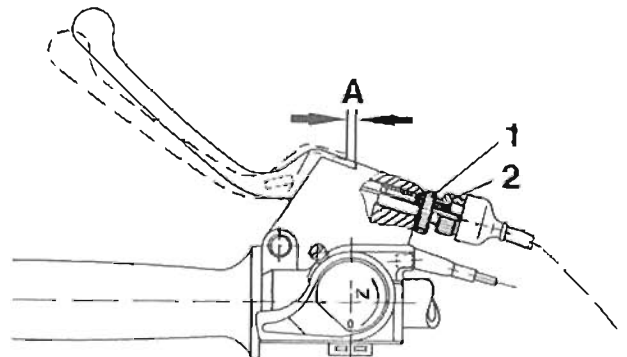

21

Clutch

Slacken off locknut on adjusting screw.
Slacken off the adjusting screw (arrow) by one or two complete turns, then retighten slowly until the pressure point is felt. Lock the adjusting screw in this position with the locknut.

After adjusting to the basic setting, adjust clutch lever play with the adjusting screw to dimension "A" and lock with the knurled nut.

Important:

Take up excessive clearance caused by wear only at the adjusting screw on the withdrawal arm.

 "A" = 2 + 0.5 mm

 "A" = 2 + 0.5 mm

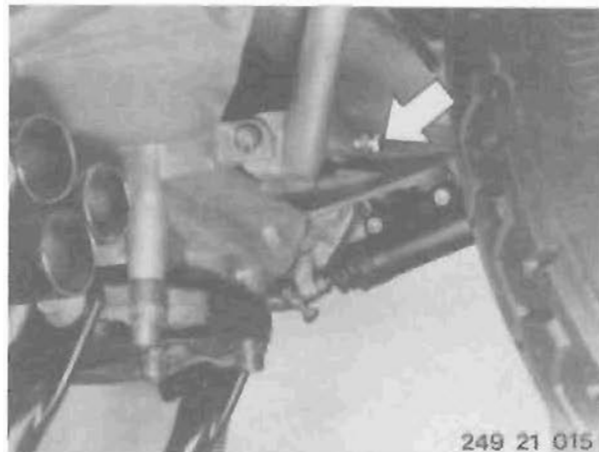

Clutch thrust bearing – removing

Remove the silencer (see Group 18).
Disconnect the clutch cable at the withdrawal arm (arrow).



Release the clamp (arrow) at the sealing bushing and take off the bushing with spring.



Take out the thrust piston with pliers.
Take out the ball bearing.



Clutch thrust rod – removing

Remove the gearbox (see Group 23).
Remove the clutch thrust bearing (see page 21 – 10.0).
Drive out the clutch thrust rod to the front with an arbor.
Take out the bearing reaction ring to the rear.

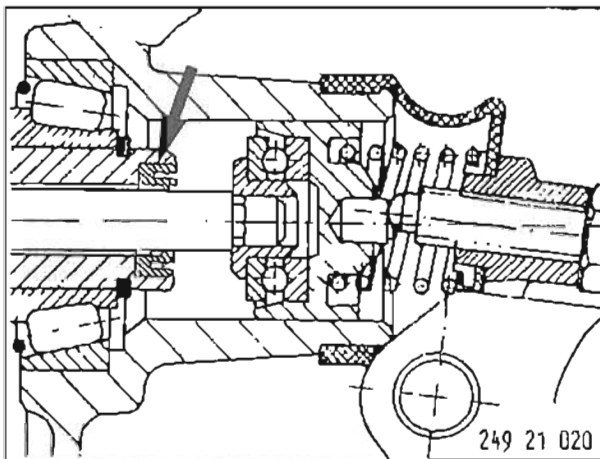

Output shaft sealing ring – removing and installing

Remove the clutch thrust rod (see above).
Carefully lever out the shaft sealing ring (arrow) with a screwdriver.
Drive in the new shaft sealing ring with a suitable tool (e.g. an old thrust rod from the gearbox of a 4-cylinder engine) until it is flush.

When installing:

The spring washer faces outwards.

Clutch thrust rod – installing

Install the clutch thrust rod with BMW assembly sleeve 23 1 800.
Press the bearing reaction ring on to the thrust rod with a suitable tube

Clutch thrust bearing – installing

Install the ball bearing and thrust piston.
Place the spring on the piston. Fit the bushing and secure to the gearbox with the clamp.
Attach the clutch cable to the withdrawal arm.
Check the clutch operating clearance and adjust if necessary (see page 21 – 09.0).

Note:

Grease the bearing with Shell Retinax A before installing.

23

Gearbox

23 Gearbox

Specifications	Page	23-03.0
Tightening torques		23-05.0
Diagrams		23-07.0
Gearbox – removing		23-13.0
Exhaust system – removing		23-13.0
Rear wheel – removing		23-14.0
Left or right footrest plate – removing		23-14.0
Rear mudguard – removing		23-16.0
Fuel injection control unit – removing		23-17.0
Battery removing		23-17.0
Spring strut – removing		23-19.0
Final drive – removing		23-19.0
Rear swing arm – removing		23-19.0
Gearbox – removing		23-20.0
Gearbox – installing		23-21.0
Rear swinging arm – installing		23-23.0
Final drive – installing		23-24.0
Battery – installing		23-24.0
Fuel injection control unit – installing		23-25.0
Rear mudguard – installing		23-25.0
Right footrest plate – installing		23-25.0
Rear wheel – installing		23-26.0
Exhaust system – installing		23-26.0
Gearbox – stripping down and assembling		23-29.0
Gearbox cover – removing		23-29.0
Selector drum – removing		23-30.0
Selector forks – removing		23-30.0
Gearbox shafts – removing		23-30.0
Selector pawl – removing		23-31.0
Selector shaft – removing		23-31.0
Shift segment – removing		23-31.0
Stop lever – removing and installing		23-31.0
Selector pawl – stripping down		23-32.0
Selector pawl – assembling		23-32.0
Shift segment – stripping down		23-32.0
Shift segment – assembling		23-32.0
Bearing shell for input shaft taper roller bearings – removing and installing		23-33.0
Intermediate shaft ball bearings – removing and installing		23-33.0
Input shaft – stripping down and assembling		23-34.0
Output shaft – stripping down		23-36.0
Output shaft – assembling		23-37.0
Gearbox assembling		23-38.0
Selector shaft – installing		23-38.0
Selector pawl – installing		23-38.0
Gearbox shafts – installing		23-38.0
Selector forks – installing		23-39.0
Selector drum – installing		23-39.0
Gearbox shafts – spacing out		23-40.0
Gearbox cover – installing		23-42.0
Shaft seal ring in gearbox cover – installing		23-42.0
Shaft seal ring for output shaft – installing		23-43.0
Pedal switch – removing and installing		23-43.0

Gearbox

Specifications

Model	K 75	K 75 c	K 75 s	K 100	K 100 RS	K 100 RT	K 100 LT
Type of gearbox	5-speed, with claw shift and integral shock damper for all gears						
Gear change mechanism	With variable-position pedal and selector drum with overshoot protection						
Gear ratios:							
1st	4.50						
2nd	2.96						
3rd	2.30						
4th	1.88						
5th	1.67						
Oil grade	above 5°C	SAE 90 brand-name hypoid gear oil					} API classification GL 5
	below 5°C	SAE 80 brand-name hypoid gear oil					
	all year round	SAE 80 W 90 brand-name hypoid gear oil					
Oil quantity	l	0.85 ± 0.05					
Intermediate shaft endplay	mm	0.05 ... 0.15					
Output shaft endplay	mm	0.05 ... 0.15					
Preload input shaft	Preload mm $\hat{=}$ app. friction value Nm						
	0.03 $\hat{=}$ 0.19 ± 0.02						
	0.055 $\hat{=}$ 0.34 ± 0.02						
	0.08 $\hat{=}$ 0.5 ± 0.02						

Gearbox

Tightening torques

Connection	Nm
Gearbox cover to gearbox	9 ± 1
Spring bearing bolt to gearbox cover	13 ± 2
Headless screw to selector shaft	17 ± 2
Gearbox to intermediate flange	16 ± 1
Frame to gearbox	45 – 6
Retaining mount to gearbox	41 ± 5
Fixed swinging arm bearing to gearbox	9 ± 1
Movable swinging arm bearing journal	7.5 ± 0.5
Locknut for movable swinging arm bearing	41 ± 3
Final drive to swinging arm	40 ± 3
Spring strut to frame/final drive	51 ± 6
Starter motor to gearbox	7 ± 1
Brake caliper to final drive	32 ± 2
Wheel studs (rear wheel)	105 ± 4
Exhaust manifold pressure plate to cylinder head	21 ± 2
Silencer to footrest plate	9 ± 1
Oil drain screw to gearbox	20 ± 3
Oil filler screw to gearbox	20 ± 3
Pedal switch to selector shaft	8.5 ± 1

Gearbox

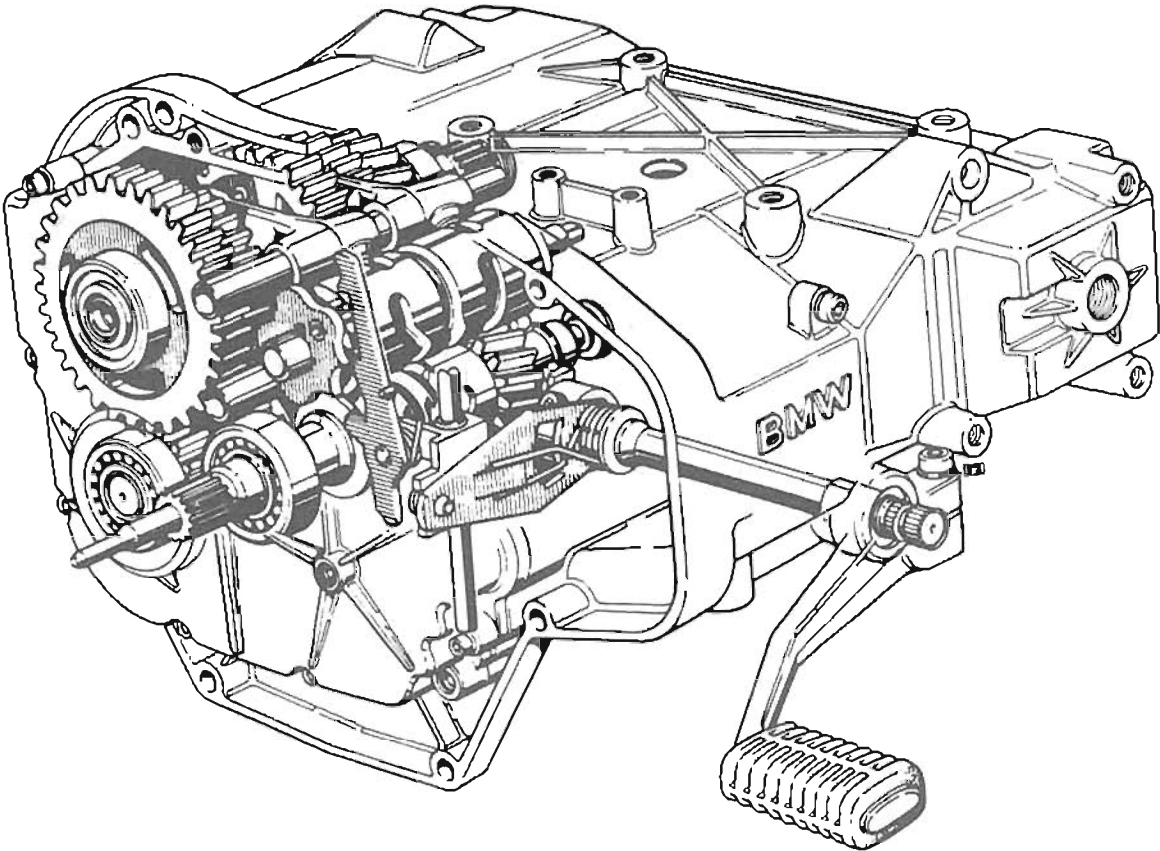

Input shaft

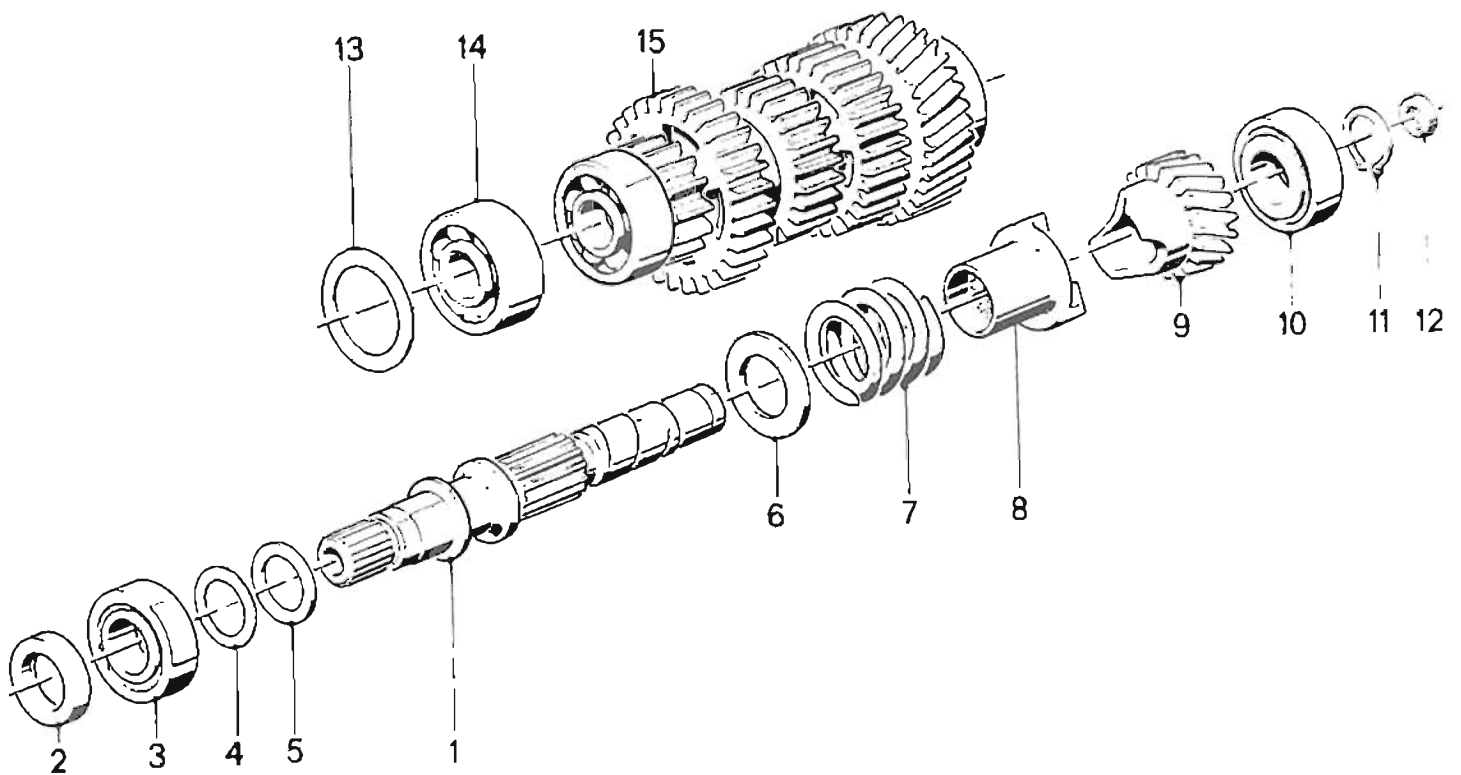

- 1 Input shaft
- 2 Shaft sealing ring
- 3 Taper roller bearing
- 4 Spacer
- 5 Spacer
- 6 Washer
- 7 Coil spring
- 8 Thrust piece

- 9 Spurgear
- 10 Taper roller bearing
- 11 Circlip
- 12 Shaft sealing ring
- 13 Spacer
- 14 Deep groove ball bearing
- 15 Intermediate shaft, complete

Output shaft

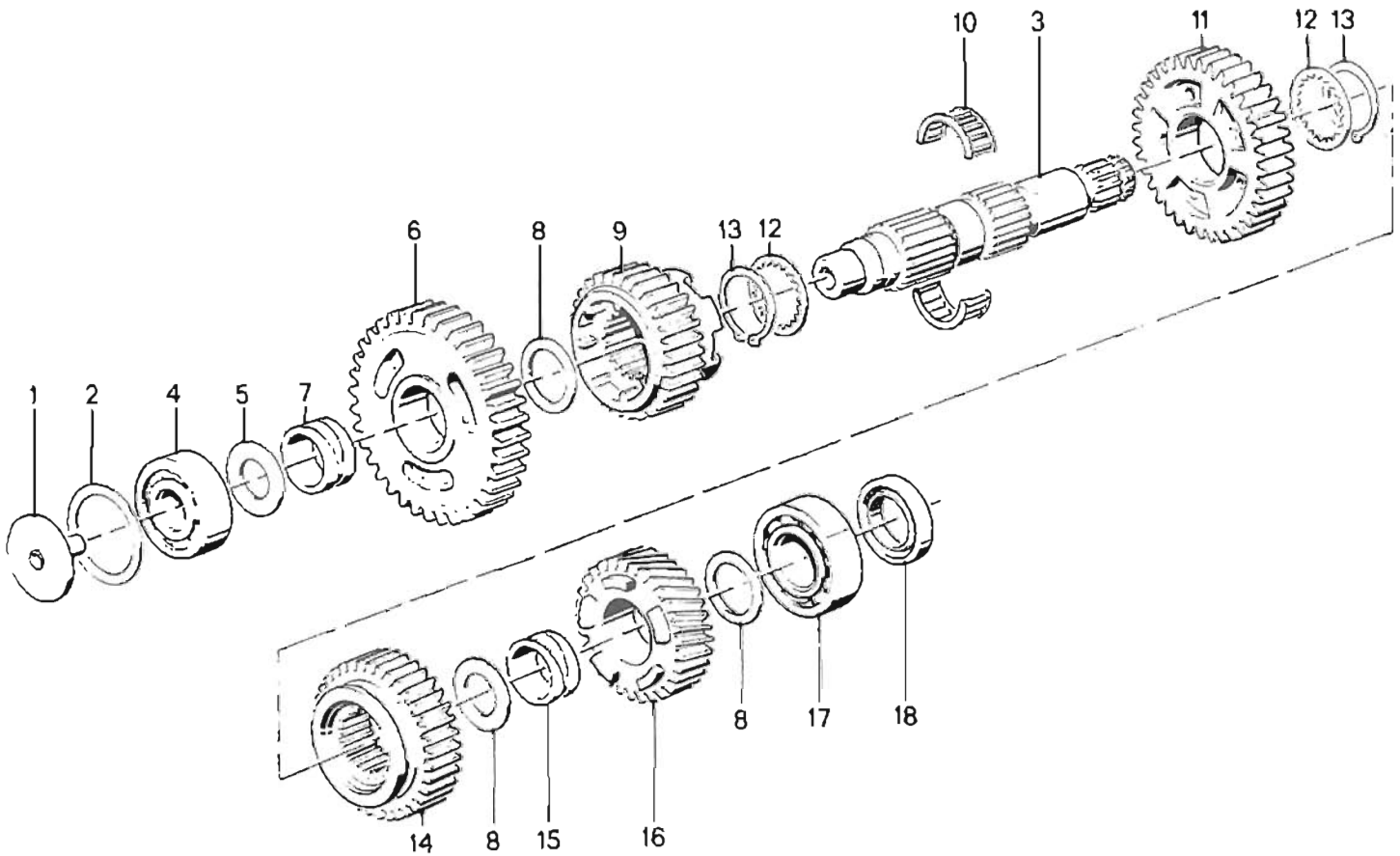

- 1 Oil trap plate
- 2 Spacer
- 3 Output shaft
- 4 Deep-groove ball bearing
- 5 Spacer
- 6 Spur gear, 1st gear
- 7 Bushing
- 8 Spacer
- 9 Spur gear, 4th gear

- 10 Needle roller cage
- 11 Spur gear, 2nd gear
- 12 Supporting ring
- 13 Circlip
- 14 Spur gear, 3rd gear
- 15 Bushing
- 16 Spur gear, 5th gear
- 17 Deep-groove ball bearing
- 18 Shaft sealing ring

Selector drum

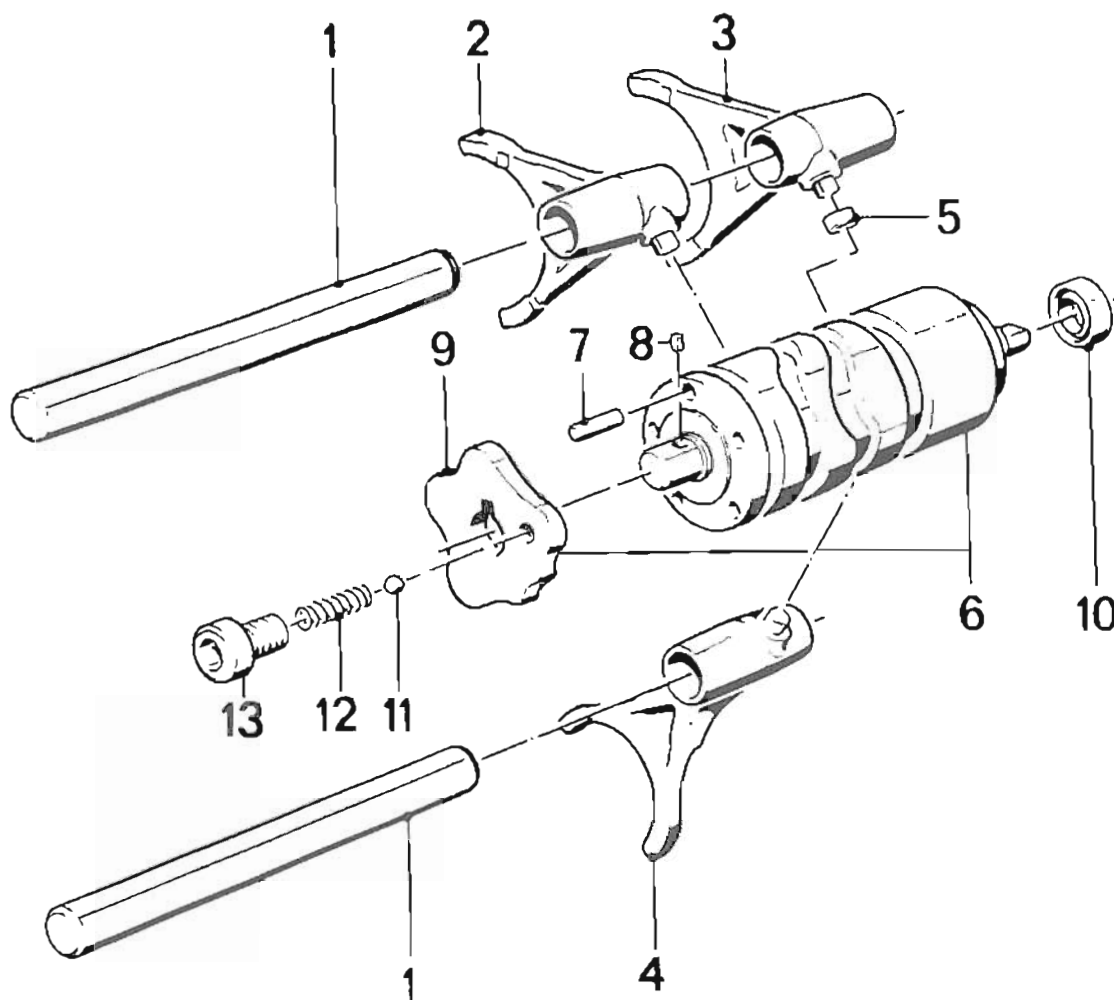

- | | |
|------------------------------------|-----------------------|
| 1 Shaft | 8 Dowel pin |
| 2 Selector fork, 1st and 2nd gears | 9 Stepped disc |
| 3 Selector fork, 5th gear | 10 Shaft sealing ring |
| 4 Selector fork, 3rd and 4th gears | 11 Ball |
| 5 Roller | 12 Coil spring |
| 6 Selector drum | 13 Machine screw |
| 7 Roller | |

Foot shift mechanism

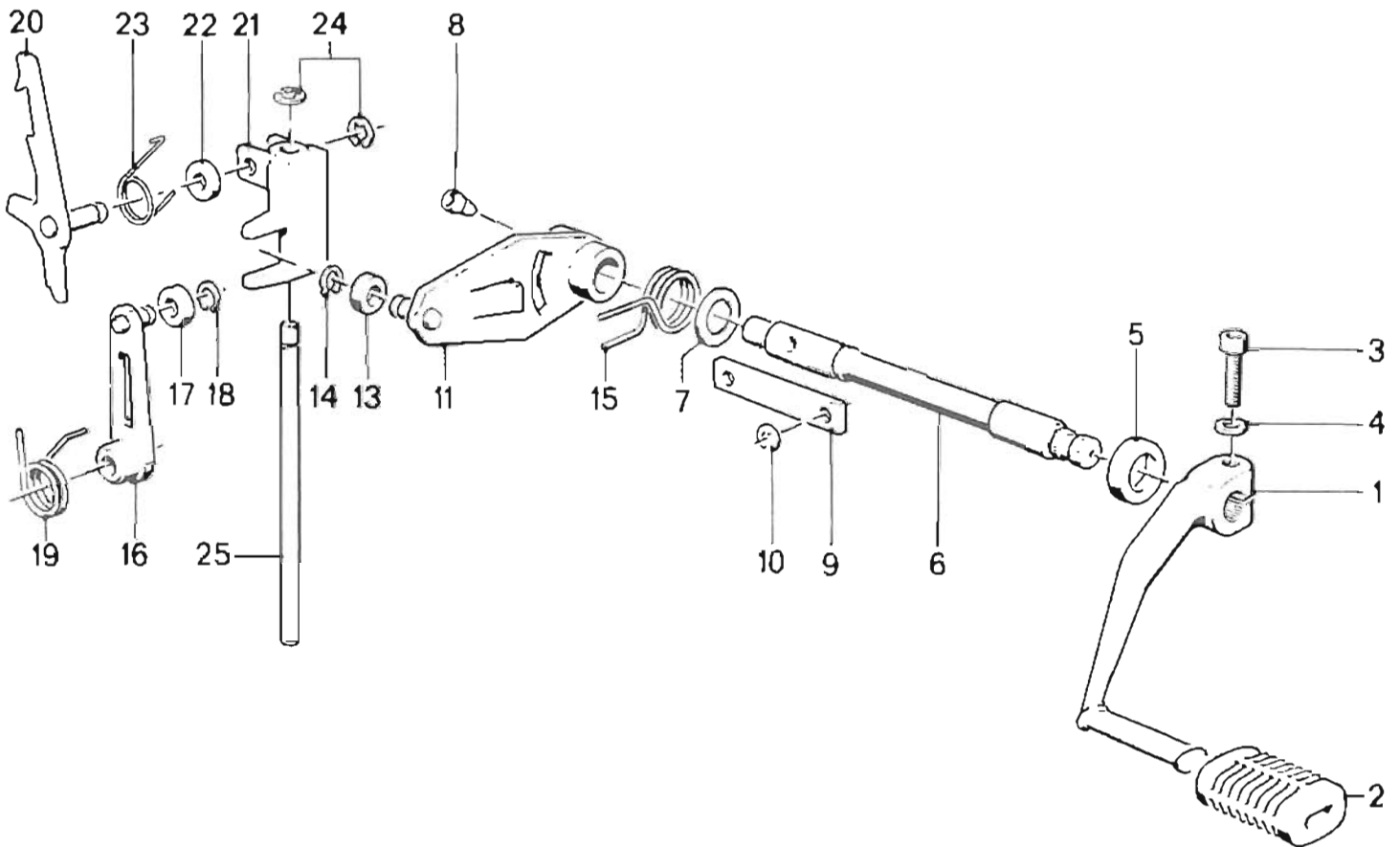

- | | |
|----------------------|------------------|
| 1 Shift lever | 14 Circlip |
| 2 Sleeve | 15 Leg spring |
| 3 Machine screw | 16 Stop lever |
| 4 Spring washer | 17 Roller |
| 5 Shaft sealing ring | 18 Circlip |
| 6 Selector shaft | 19 Spring |
| 7 Spacer | 20 Pawl |
| 8 Headless screw | 21 Pawl mounting |
| 9 Stop | 22 Spacer |
| 10 Circlip | 23 Spring |
| 11 Segment | 24 Circlip |
| 13 Roller | 25 Guide rod |

Gearbox – removing



Take off the left and right battery covers:

- pull off at bottom (1)
- pull the cover out under the fuel tank (2)
- pull the cover out of the dualseat frame to the front (3).

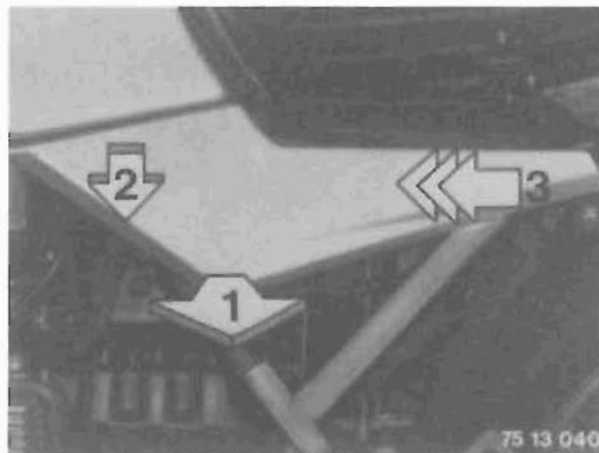

●●●● Fuel tank plug mounting

Take off the left and right battery covers:

- pull out of rubber sleeve on tank (1)
- lift out of rubber mounting at base (2)
- pull the cover out of the dualseat frame to the front (3).

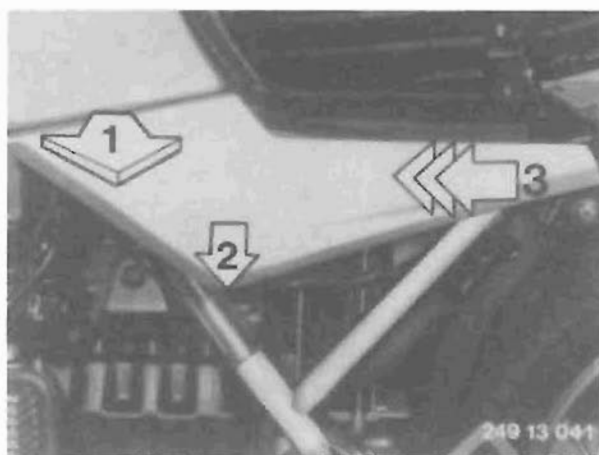

●●●● Fuel tank bridge mounting

Take off the left and right battery covers:

- pull out of rubber mounting at front and rear
- pull out of fixture on frame to the rear.

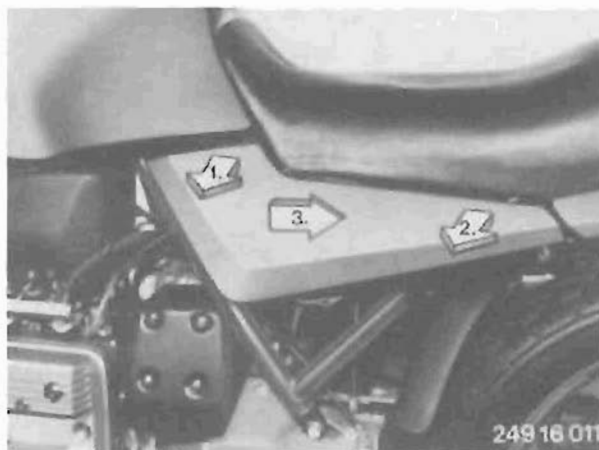

Exhaust system – removing

Slacken off the retaining nuts (arrows) for the pressure plates.

Note:

Note washers.

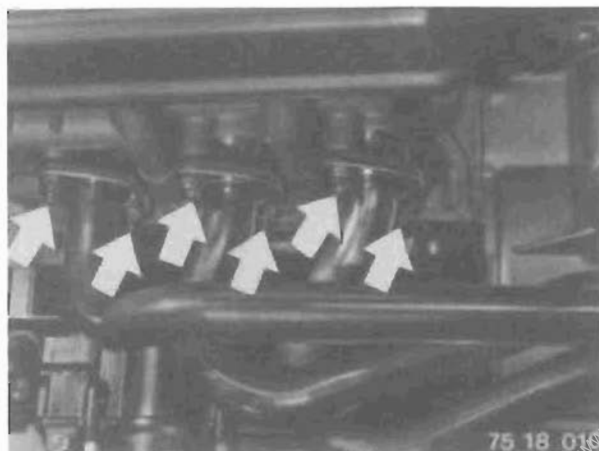

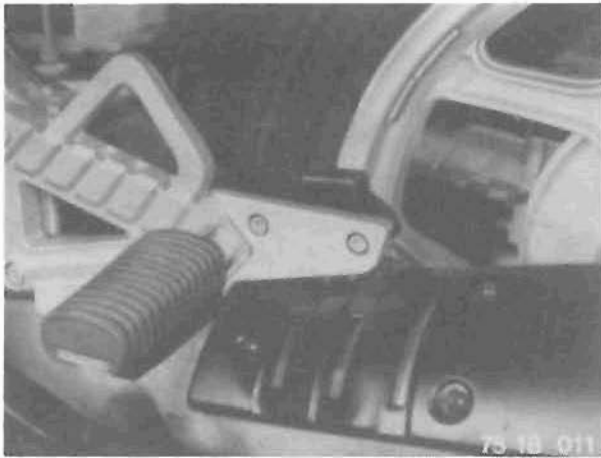

Slacken off the retaining screws on the footrest plate and take off the complete exhaust system.



Rear wheel – removing



Lever off the cover with a small screwdriver.

Slacken off the wheel studs. Pull off and take out the rear wheel.

Models with rear disc brake

Note the washer.

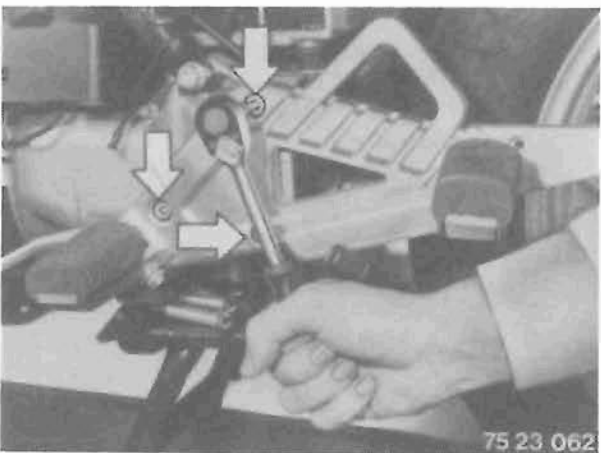

Left footrest plate – removing

Slacken off the three footrest plate retaining screws (arrows) and take off the footrest plate.

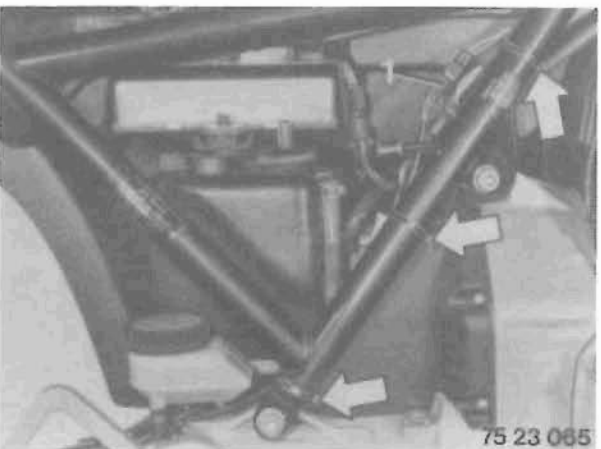

Right footrest plate – removing

Separate the cable connectors (arrows).

Separate the brake light plug connection (1).

Cable designations:

Yellow } ⇒ { Green/Grey
 Yellow } ⇒ { Green/Black

Models with rear drum brake

Slacken off the wing nut (arrow) on the brake backplate.
Pull the brake linkage out of the brake backplate.
Slacken off the three retaining screws on the footrest plate.
Remove the footrest plate with brake linkage.

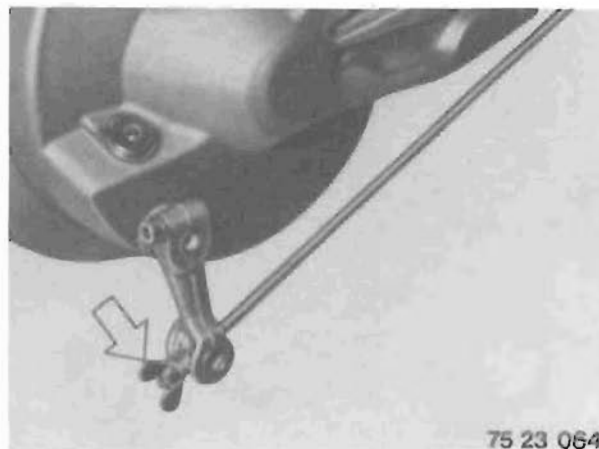

Models with rear disc brake

Slacken off both retaining nuts (1) for the brake fluid reservoir.



Slacken off the two brake caliper retaining screws (arrows).

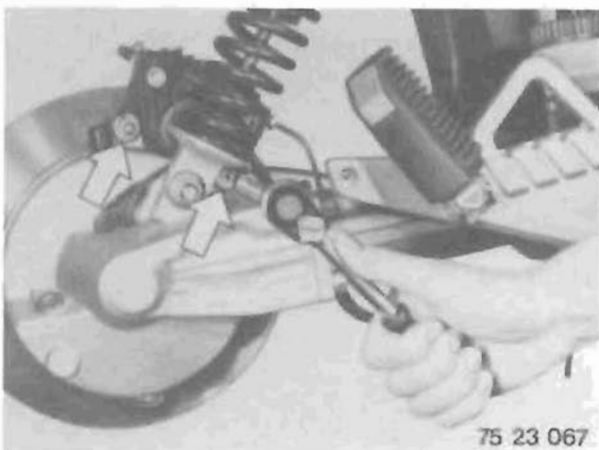

Detach the tension spring (1).



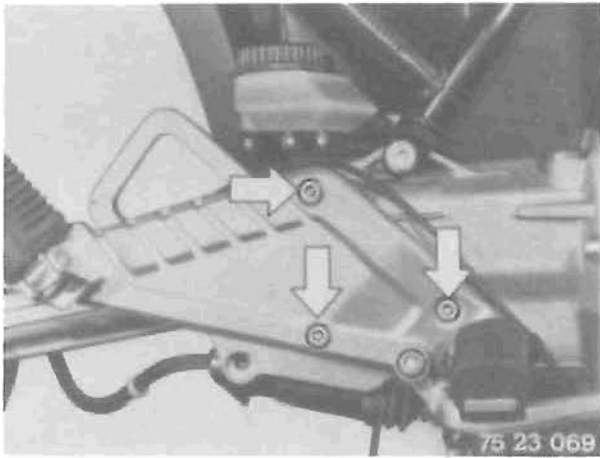

Slacken off the three retaining screws (arrows).
Take off the complete footrest plate with brake system
and brake fluid reservoir.

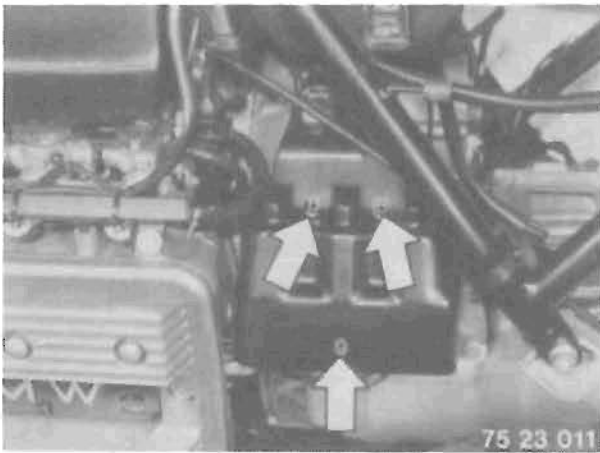

Remove the ignition coil cover.



Slacken off the three retaining screws (arrows) for the
ignition coil cover. Take off the cover.

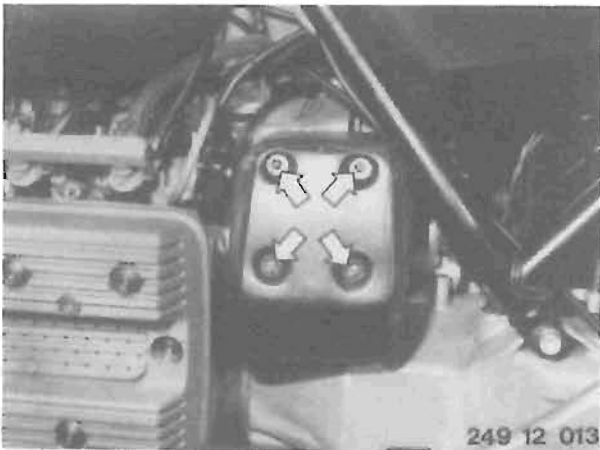

Slacken off the four retaining screws (arrows) for the
ignition coil cover. Take off the cover.



Rear mudguard – removing

Take the protective caps off the retaining screws.
Slacken off the retaining screws (arrows) for the rear
mudguard and take off the mudguard.

Fuel injection control unit – removing

Take off the cover for the multi-pin plug.

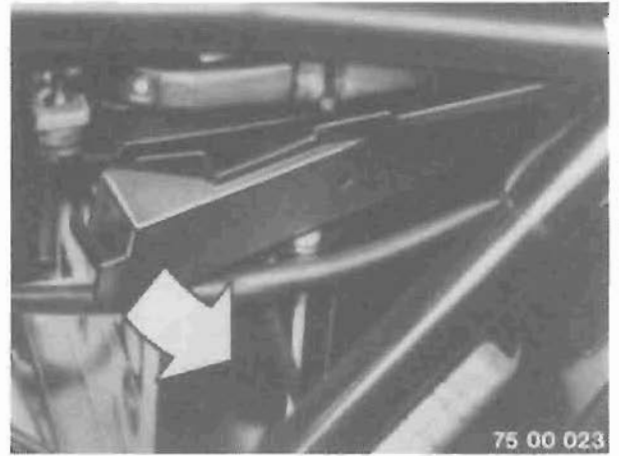

Push back the retaining hoop (1) at the multi-pin plug with a screwdriver in the direction shown by the arrow. Pull out the multi-pin plug to the rear and take it out of the front guide.

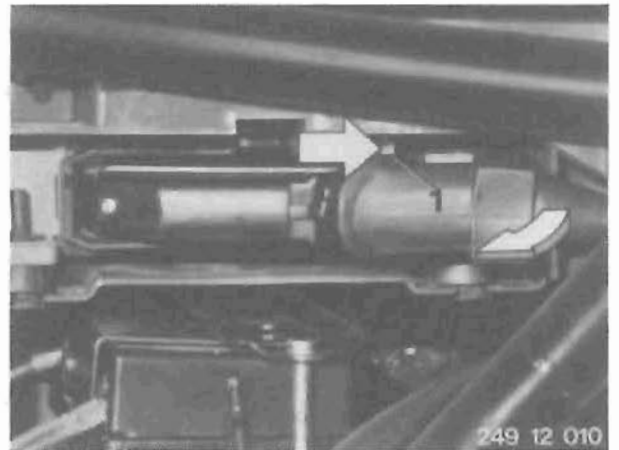

Lift out the storage tray with control unit.

Note:

Note the rubber stoppers.

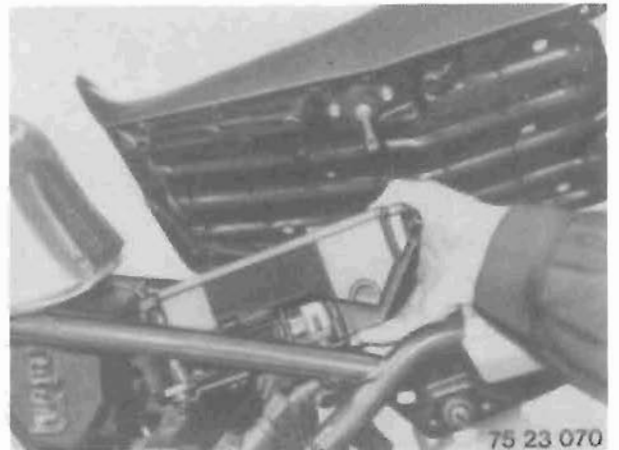

Battery – removing

- Detach the battery negative cable (1) at the gearbox
- Disconnect the positive cable (2) at the battery.
- Slacken off the battery holder retaining screws (arrows).
- Take out the battery.

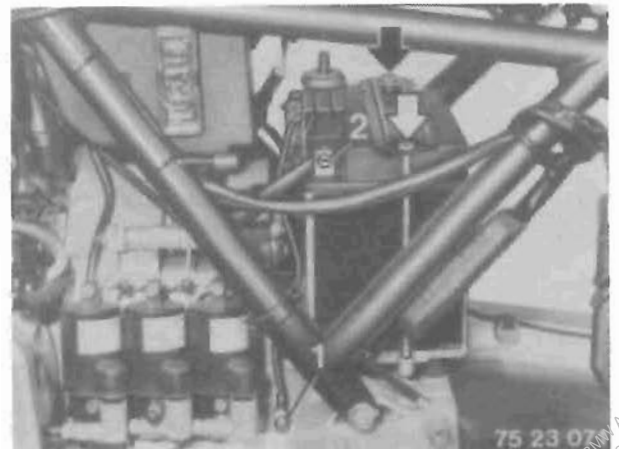

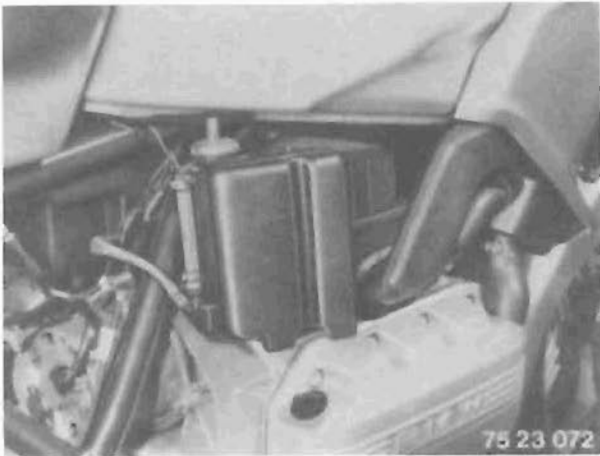

Lift the coolant equalizing tank out of the holder and secure it to the frame with wire or similar.

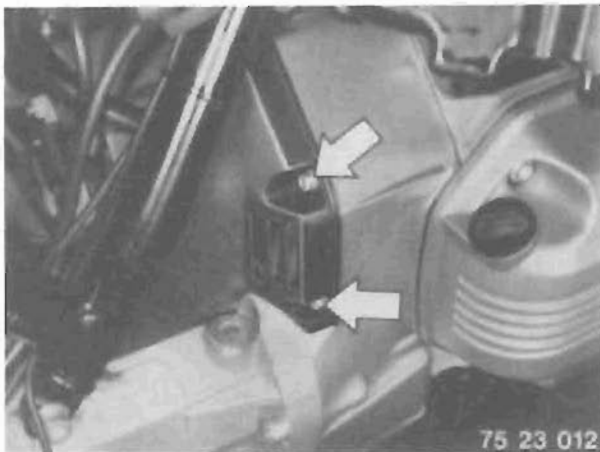

Slacken off retaining screws (arrows) and remove the alternator cover.

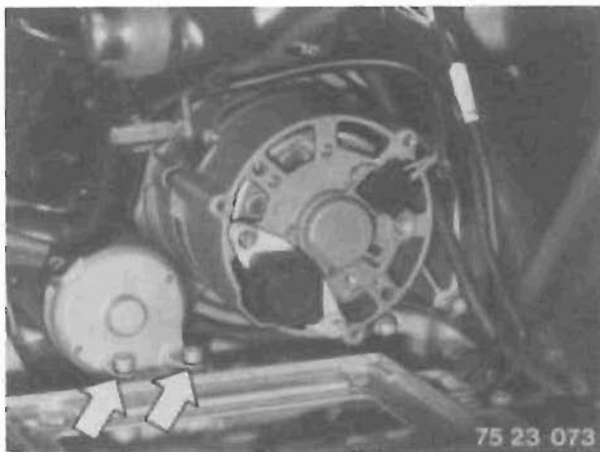

Slacken off the two retaining screws (arrows) at the starter motor.
Pull the starter motor out of the intermediate flange.

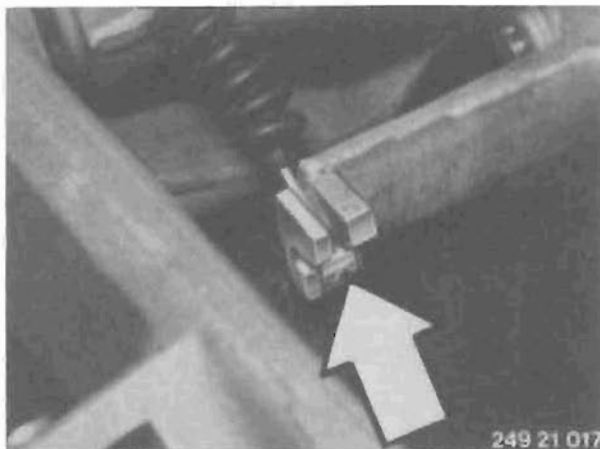

Detach the clutch cable (arrow) and pull it out of the gearcase.

Spring strut – removing:

Important:

When removing the spring strut it is important to secure the swinging arm (with strap, wire, wooden block) so that it cannot fall down and damage the gaiter on the gearbox output shaft and drive shaft. Maximum securing strap length 349 mm.

Slacken off the four final drive retaining bolts (arrows).
Slacken off the spring strut retaining screws (1) and take it off.

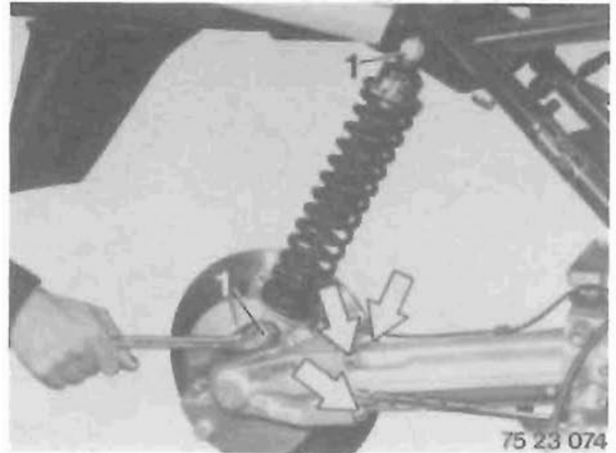

Final drive – removing

Unscrew and remove the four final drive retaining bolts.
Disconnect the plug connection for the speedometer sensor. Apply light blows to the final drive to dislodge it, and take it off.

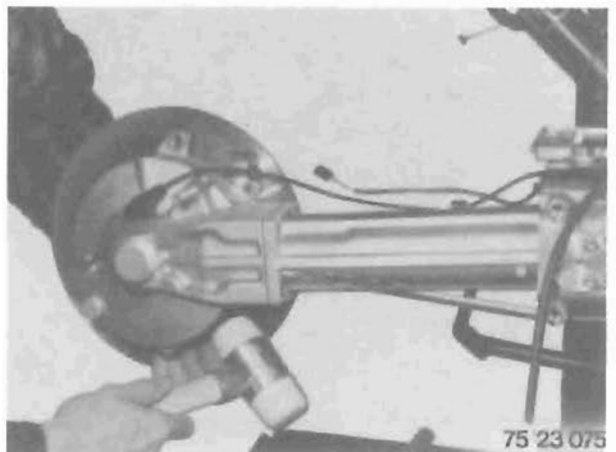

Rear swinging arm – removing

Slacken off the bearing journal locknut (arrow).
Unscrew the bearing journal with a 6 mm Allen key.

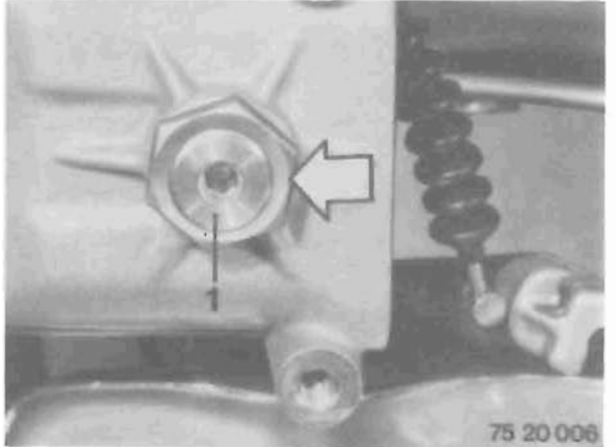

Slacken off the three retaining screws (arrows) for the fixed swinging arm bearing.
Unscrew and remove the two bolts.
Screw BMW puller 26 1 660 in the centre hole of the fixed bearing and tighten the locknut.
Slacken off the third retaining bolt.
Pull out the fixed bearing by turning it slightly to and fro.
Take out the swinging arm.

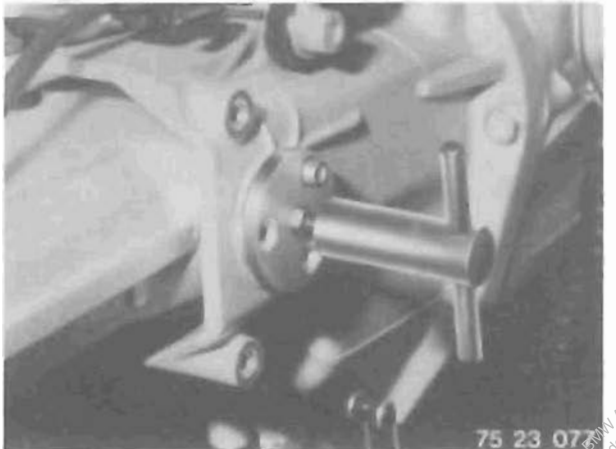

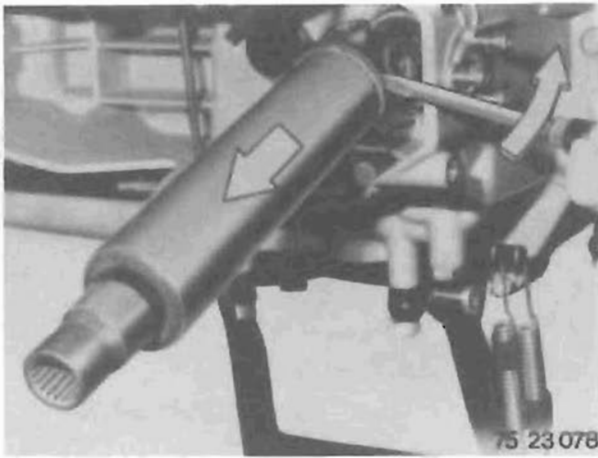

Lever off the drive shaft from the snap ring with a screwdriver and pull it off the gearbox shaft.

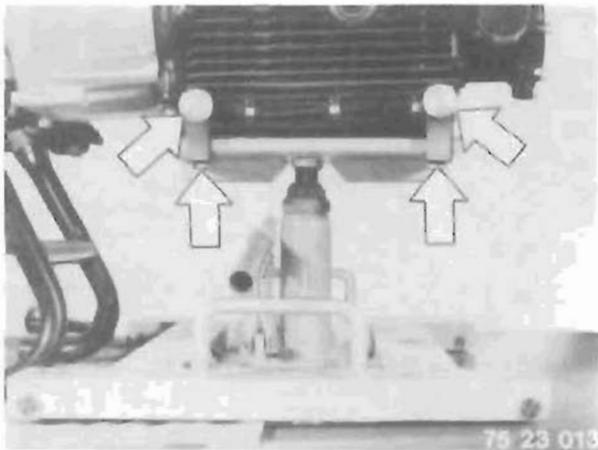

Gearbox – removing

Secure BMW hoist 00 1 510 to the oil sump and tighten the knurled nuts and hex nuts (arrows). Lift the engine until there is no load on the centre stand.

Note:
Secure the front wheel with retaining device (press down).

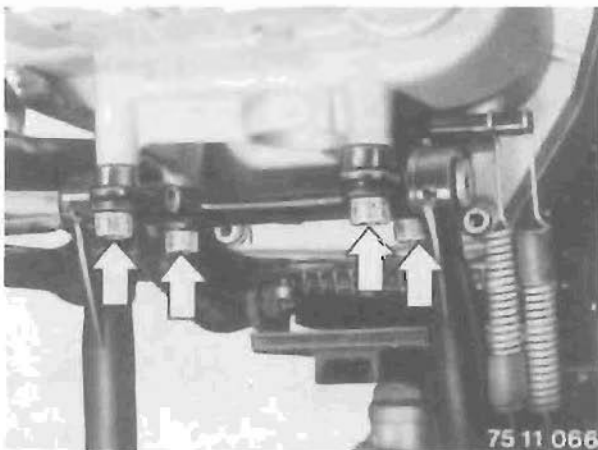

Disconnect pull rod from lever for side stand return mechanism on “automatic side stand” special equipment option.

Slacken off the retaining screws (arrows) for mounting bracket on the underside of the gearbox. Remove mounting bracket with main stand and side support.

Note:
Screws are microencapsulated (self-locking) and cannot be reused.

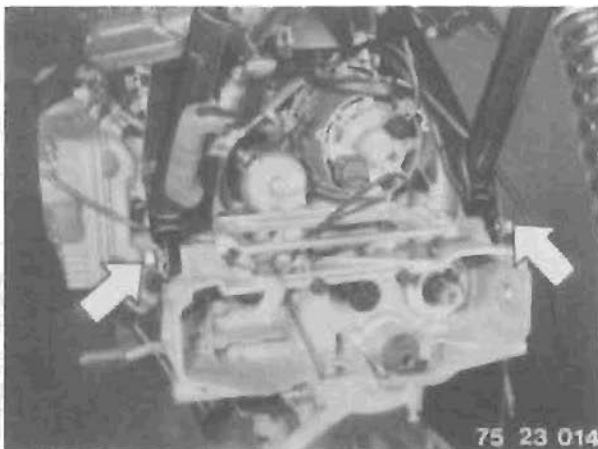

Disconnect the plug connection for the gear switch. Slacken off the frame retaining screws (arrows) at the left and right of the gearbox.

Slacken off the screws (arrows) securing the gearbox to the engine and pull the gearbox down to remove.

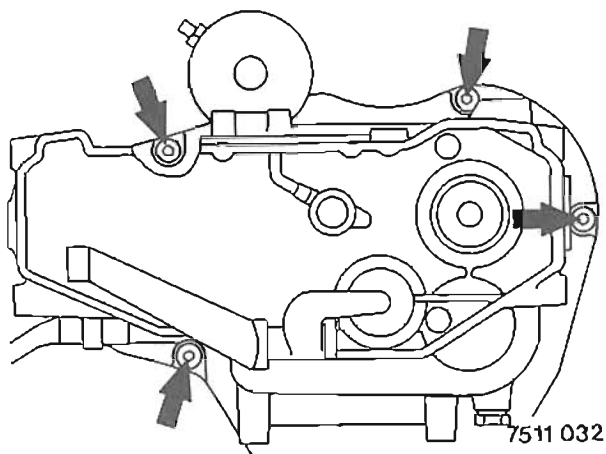

Gearbox – installing

Before installing the gearbox, check that the clutch is centred with centering arbor BMW No. 21 2 670. Slacken off the lower retaining screw (arrow) on the ignition coil mounting.

Attach centering bridge (1) to the intermediate flange. Check that the clutch is centred with centering arbor (2).

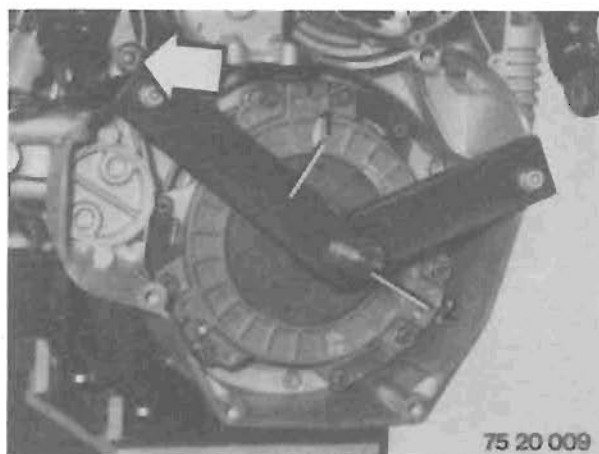

Loosen retaining screws (arrows) on clutch housing cover if necessary.

Centre the clutch and tighten the retaining screws evenly in a crosswise pattern.

Remove the centering device.

Tightening torque:

Retaining screws

$19 \pm 2 \text{ Nm}$

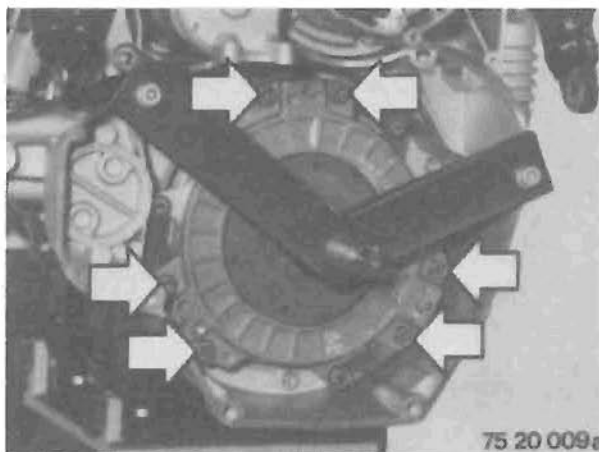

Coat the tip of the thrust rod and the teeth of the drive pinion with "Staburags".

Introduce the clutch thrust rod through the centre of the clutch hub (dotted line).

Hold the gearbox in a precisely horizontal position and note the holes drilled in the gearbox/frame.

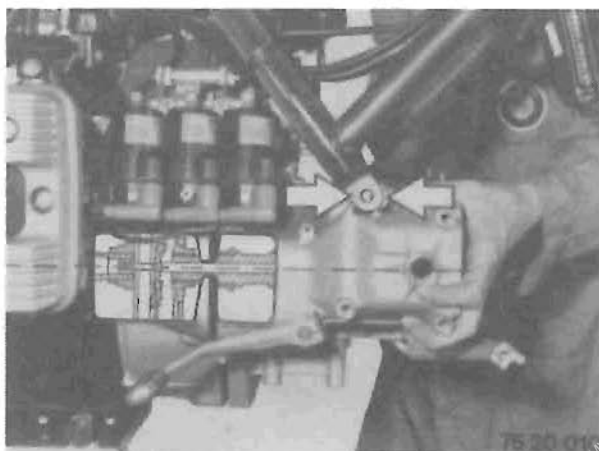

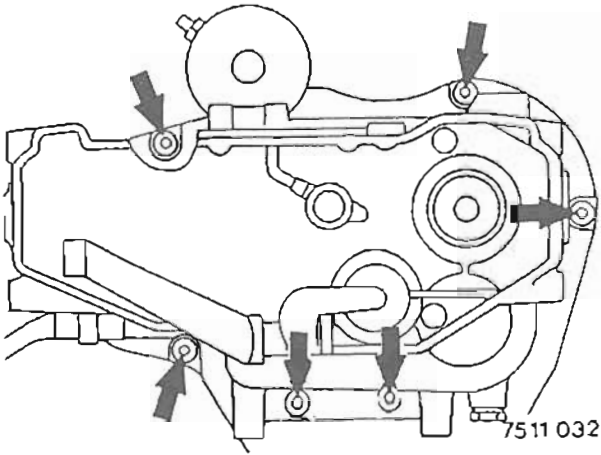

Screw the gearbox on to the engine with six retaining screws (arrows).

Tightening torque:
Retaining screws

$16 \pm 1 \text{ Nm}$



Screw the frame and the gearbox together with two retaining screws.

Tightening torque:
Retaining screws

$45 - 6 \text{ Nm}$

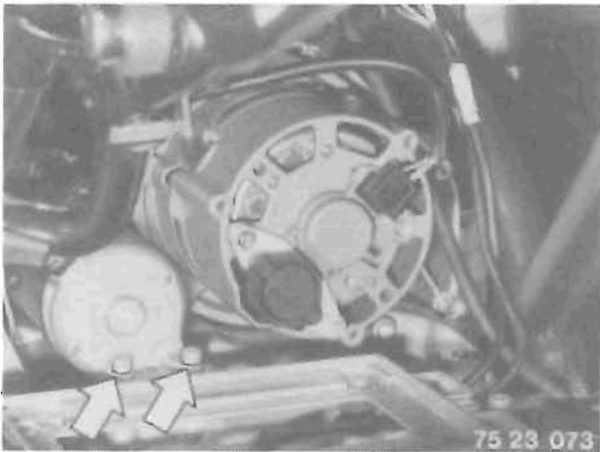

Insert the starter in the intermediate flange and tighten the retaining screws (arrows) for the starter.

Tightening torque:
Retaining screws

$7 \pm 1 \text{ Nm}$

Secure the ignition coil holder on the intermediate flange.

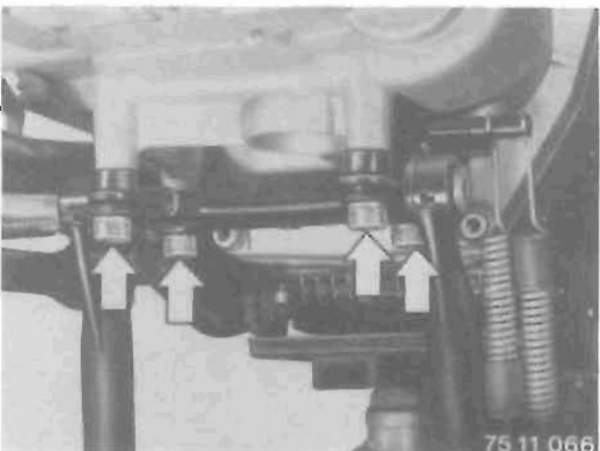

Secure the mounting with centre stand and side support to the gearbox with four retaining screws.
If special equipment option "automatic side stand" is fitted, locate the pull rod in the lever.

Note:

Retaining screws are microencapsulated.
If re-used, remove locking agent from the thread passages (screw and gear housing). Coat retaining screws with Loctite 242, screw in and tighten.

Tightening torque:
Retaining screws

$41 \pm 5 \text{ Nm}$

Remove BMW hoist 00 1 510.
Seal off threaded holes in oil sump with stoppers.

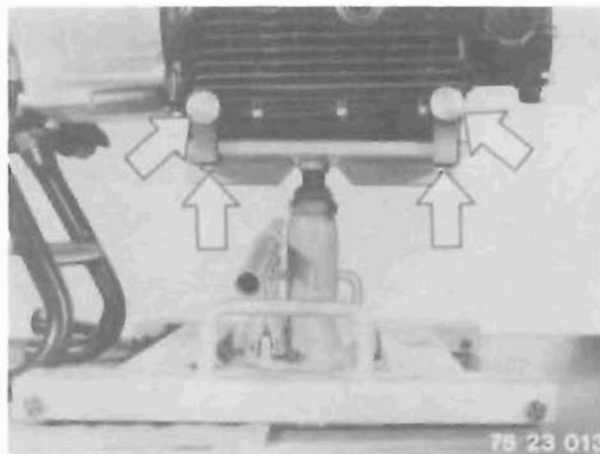

Rear swinging arm – installing

Coat the output shaft splines at the gearbox and the inside of the rubber bushing with "Staburags".
Press the swinging arm (without drive shaft) on to the gear housing, turning it slightly to and fro.
Pull back carefully to check that the rubber bushing is located over the shoulder on the gearcase.

Note:

Never fit the swinging arm with the rear wheel mounted, as the sleeve will not snap into position.

Warning:

It is vital to support the swinging arm to prevent it from falling.

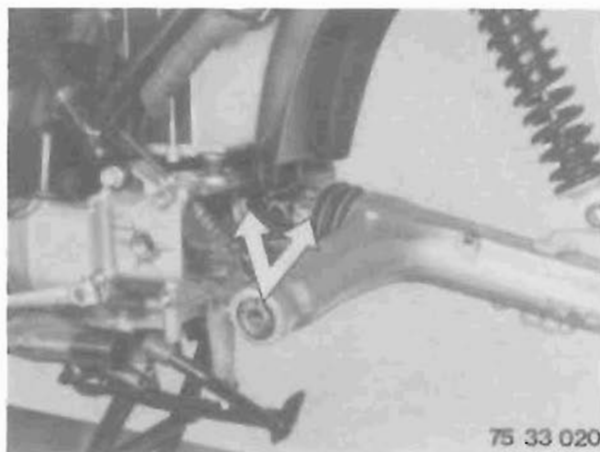

Coat the fixed swinging arm bearing journals (11) with "Never Seez".
Insert the fixed swinging arm bearing in the swinging arm mounting with a slight turning movement with the aid of BMW puller 26 1 660 and secure with a slight turning movement with three retaining bolts.

Tightening torque:

Fixed swinging arm bearing screw $9 \pm 1 \text{ Nm}$

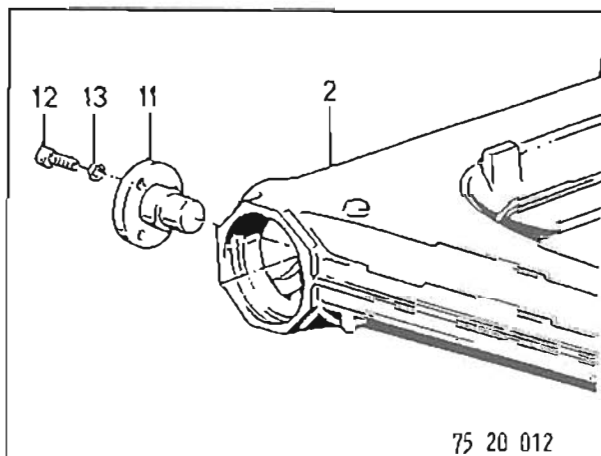

Coat the moving swinging arm bearing journal (arrow) with "Never Seez".
Pull the swinging arm towards the moving swinging arm bearing.
Insert the bearing journal and screw it into the gear housing by hand.
Tighten the bearing journal with a torque wrench.
Screw on the locknut (1) and tighten with a torque wrench.

Tightening torques:

Moving swinging arm bearing journal $7.5 \pm 0.5 \text{ Nm}$
Locknut $41 \pm 3 \text{ Nm}$

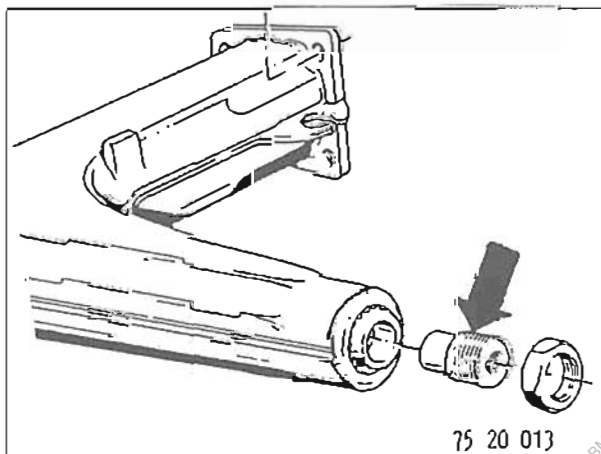

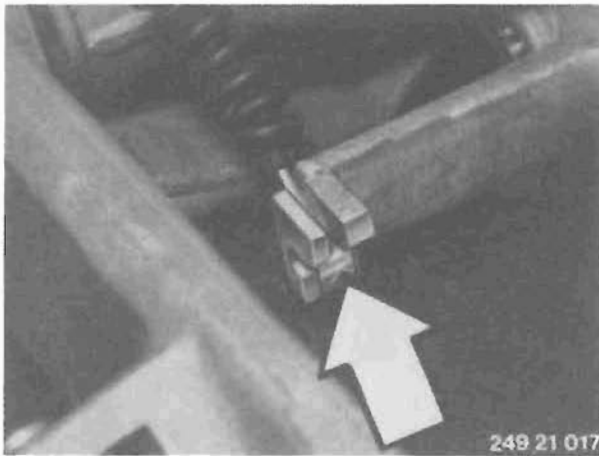

Coat the splines on the drive shaft with "Staburags". Insert the drive shaft in the swinging arm and push it over the splines. The snap ring must be heard to engage. Run the clutch cable through the gear housing. Push up the clutch withdrawal lever by hand and attach the clutch cable.

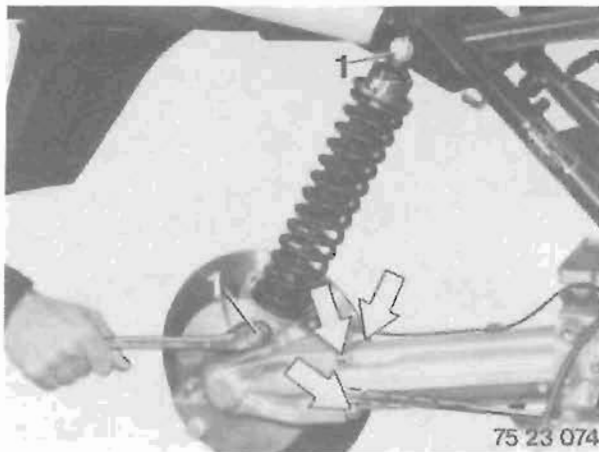

Final drive – installing

Coat the final drive pinion splines with "Staburags". Secure the final drive to the rear swinging arm with the four retaining bolts (arrows).

Tightening torque:

Final drive to swinging arm $40 \pm 3 \text{ Nm}$

Install the spring strut:

Install the spring strut with the preload bushing at the top.

Tightening torques:

Spring strut to frame

$51 \pm 3 \text{ Nm}$

Spring strut to final drive

$51 \pm 3 \text{ Nm}$



Attach the coolant equalizing tank to the mounting on the battery baseplate.

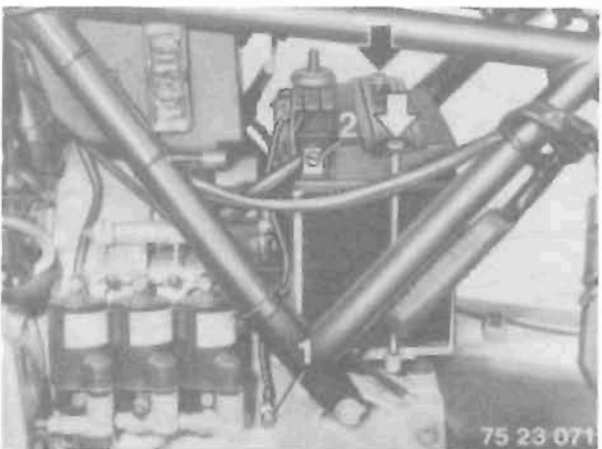

Battery – installing

Screw the positive cable (2) to the positive post on the battery.

Screw the negative cable (1) to the gearbox.

Gently screw on the battery holder with two retaining screws (arrow).

Note:

The cooling equalizing tank is retained securely at the same time.

Fuel injection control unit – installing

Place the storage tray with fuel injection control unit in the rubber bearing.

Engage the multi-pin plug in the guide at the front and connect it up; the retaining hoop must engage.

Attach the control unit cover.

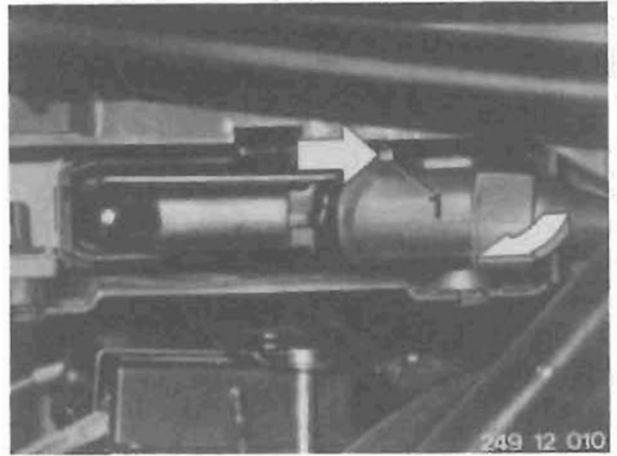

Rear mudguard – installing

Insert hoop with threaded pins (short at front, long at back) through rear mudguard from below.

Screw on nuts (arrows).

Attach the protective caps.

Note:

Fit the licence plate before tightening the nuts.



Right footrest plate – installing

Model with rear disc brake

Screw on footrest plate with three retaining screws.

Attach the tension spring for the brake lever.

Insert the brake fluid tank in the holding plate and tighten retaining nuts.

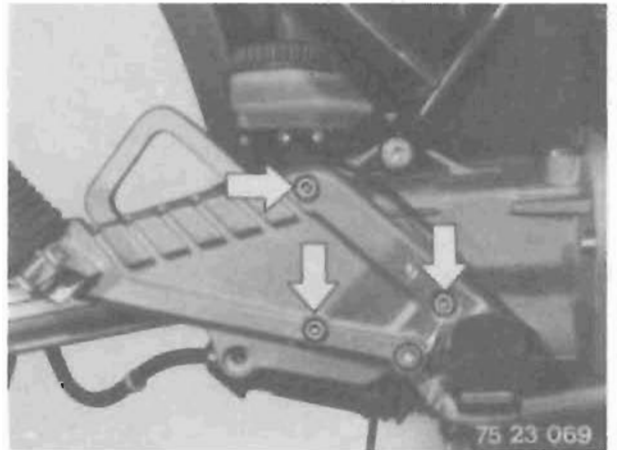

Screw on the brake caliper with two retaining screws. Remember to install the retaining bracket under the front retaining screw.

Insert the brake line with rubber washer in the mounting on the rear swinging arm.

Tightening torque:

Brake caliper retaining screws

$32 \pm 2 \text{ Nm}$

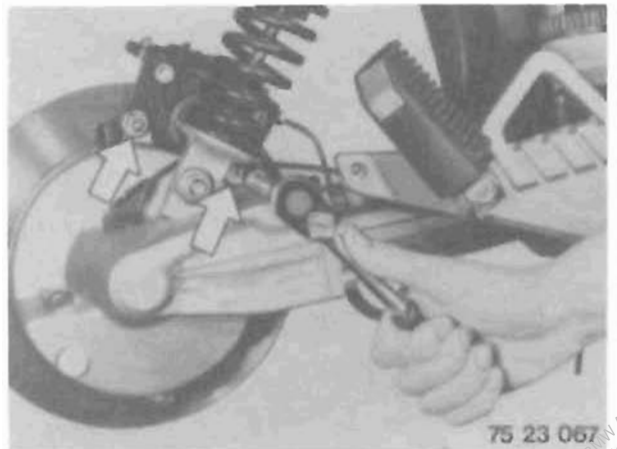

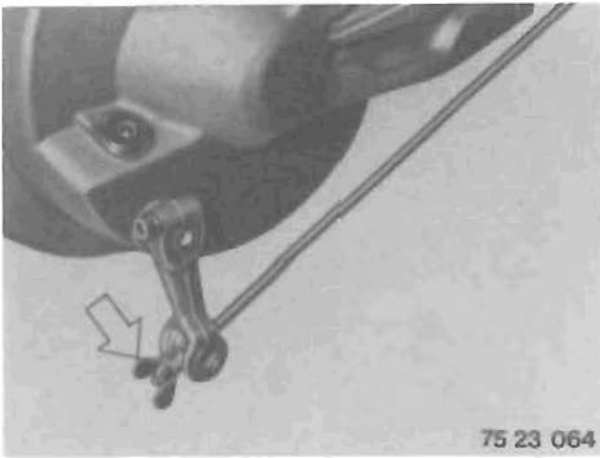

75 23 064

Models with rear drum brake

Secure the footrest plate with three retaining screws. Run the pull rod through the brake backplate and screw on the wing nut (1).

Rotate the rear wheel and turn the wing nut on the pull rod until the wheel is just braked.

Then slacken off the wing nut by 3 to 4 turns (equivalent to app. 25 mm foot brake lever play).

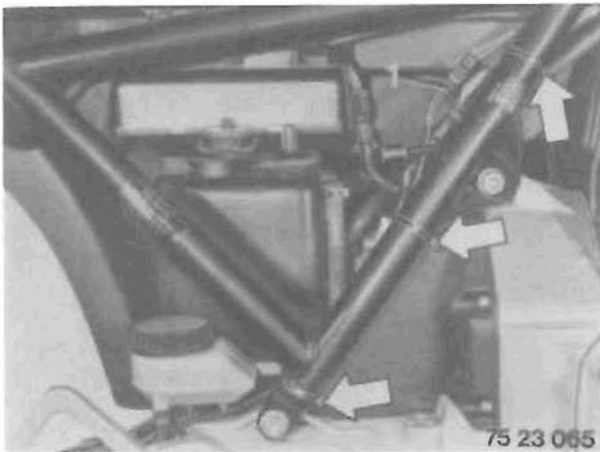

75 23 065

All models

Connect up plugs for brake light (1), speedometer sensor and gear switch.

Attach cable connectors (arrows).



75 23 063

Rear wheel – installing

The wheel centering surface and wheel hub contact faces must be absolutely clean and free of all traces of grease.

Note:

Use only 55 mm long wheel studs for rear drum brakes, and 60 mm long wheel studs for rear disc brakes. Note the designation number on the stud head.

Tightening torque:

Wheel studs

105 ± 4 Nm

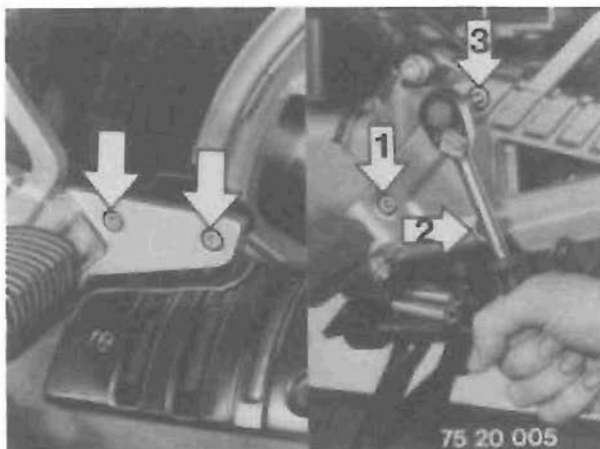

75 20 005

Left footrest plate – installing

Attach the footrest plate with three retaining screws (see illustration, centre).

Exhaust system – installing

Insert the two silencer mounting bolts through the footrest plate and screw on the stop nuts.

Tightening torque:

Silencer on footrest plate

9 ± 1 Nm

Insert the manifold with pressure plates and screw on with two copper nuts in each case.
Tighten the silencer retaining bolts.

Tightening torque:

Pressure plate to cylinder head

$21 \pm 2 \text{ Nm}$

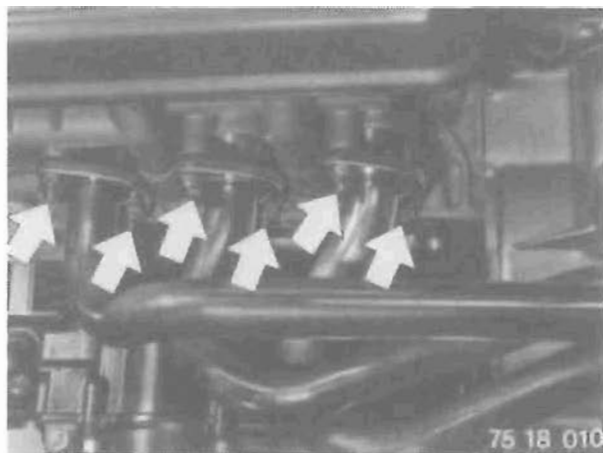

Install the alternator cover.
Install the left and right battery covers.

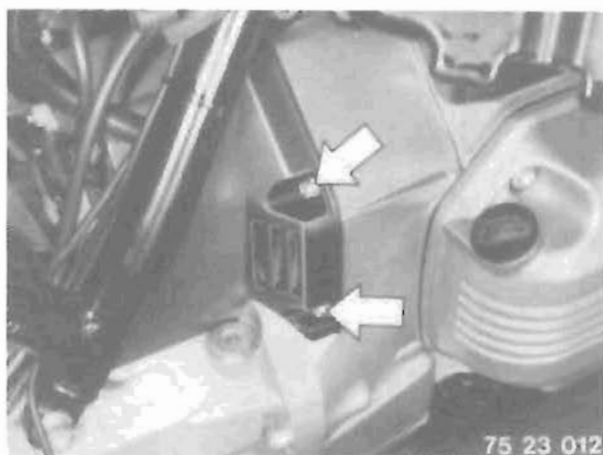

Gearbox – stripping down

Place the gearbox on BMW assembly device 23 1 600 and secure it.
Drain off oil.

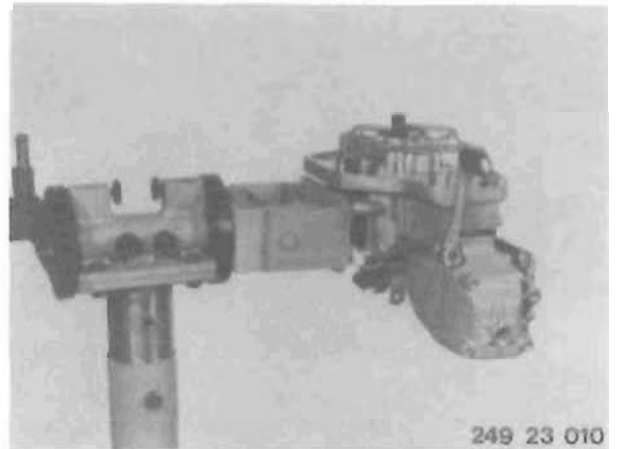

Gearbox cover – removing

Select neutral.
Slacken off the neutral stop spring bearing (1) and the gearbox cover retaining screws.

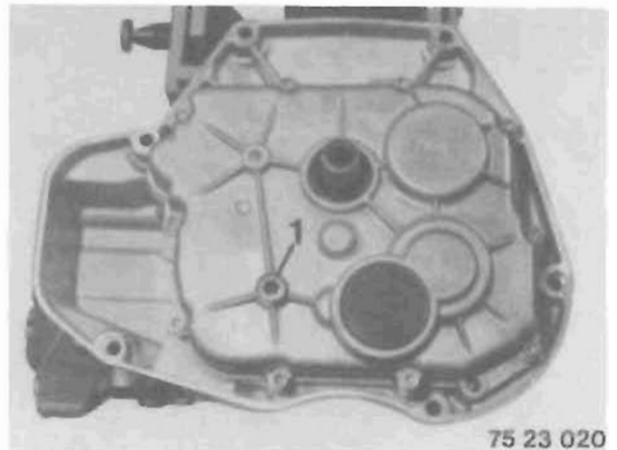

Heat the gearbox cover to app. 100°C (check with a thermochrome pin) and push it off with a screwdriver at the three points indicated.

Note:

Note the spring and ball for the neutral stop.

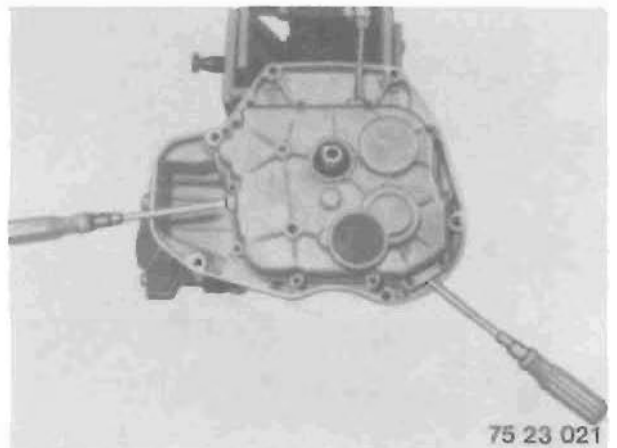

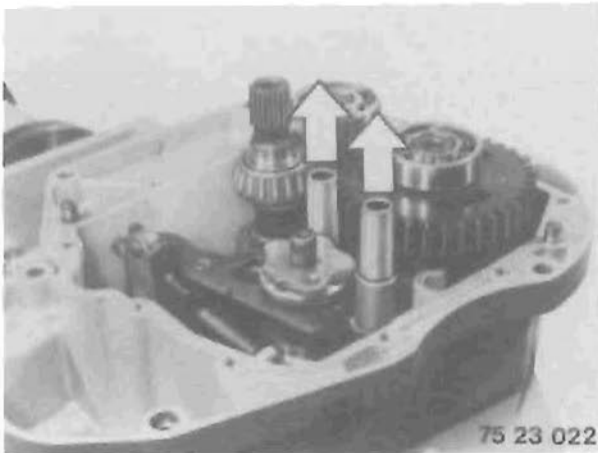

Selector drum – removing

Pull selector fork shafts out of the gear housing in the direction of the arrow.

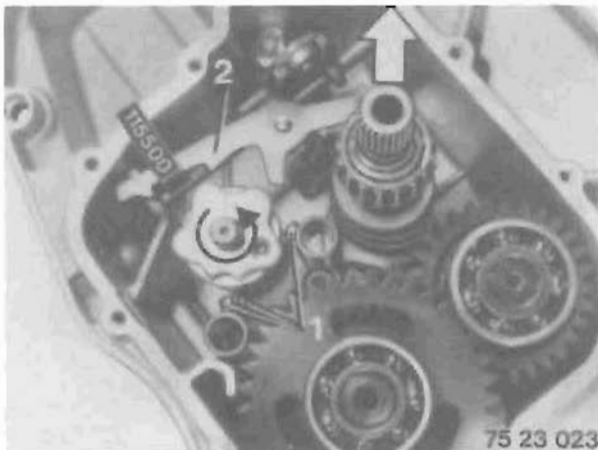

Tilt input shaft in the direction of the arrow.
Turn selector forks outwards until the guide journals (1) no longer penetrate into the selector drum.
Press the pawl (2) out manually or with BMW clamping device for chain tensioner 11 5 500.
Pull selector drum up and twist to remove.

Note:

Note the rollers on the selector fork guide journals.

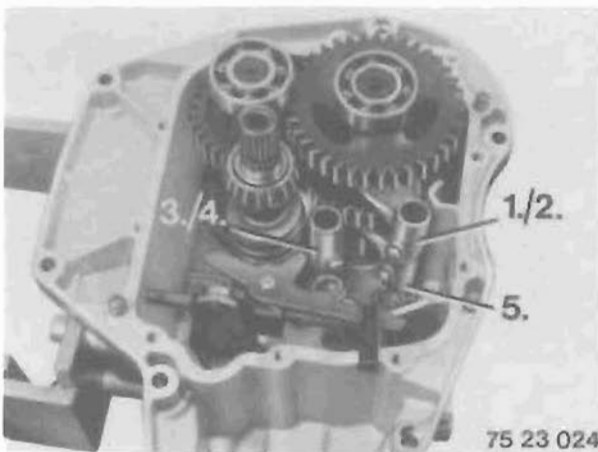

Selector forks – removing

Take out selector fork for 1st and 2nd gear.
Take out selector fork for 3rd and 4th gear.
take out selector fork for 5th gear.

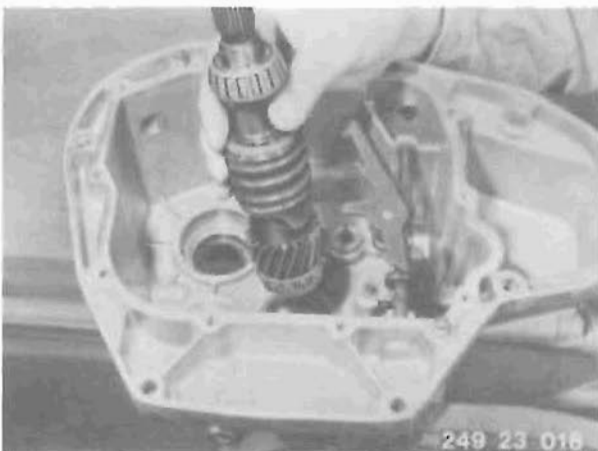

Gearbox shafts – removing

Heat up bearing sections of output shaft (1) and intermediate shaft (2) to app. 100°C (check with thermochrome pin) and remove both shafts.
Take out the input shaft (3).

Selector pawl – removing

Push out gear housing breather (1) from the inside using an arbor.
Remove circlip (2) on guide rod and pull out guide rod.
Remove pawl holder together with pawl.

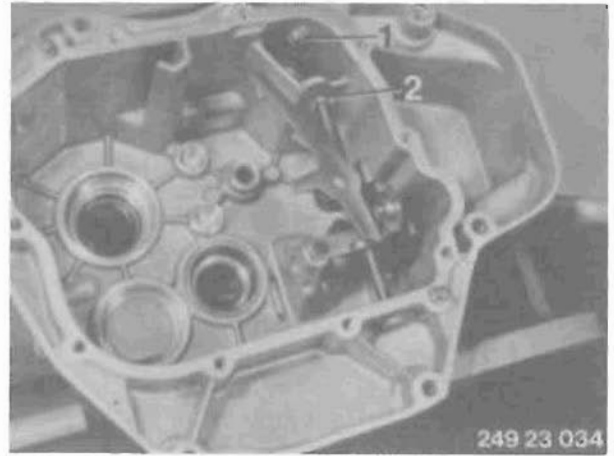

Selector shaft – removing

Slacken off headless screw (arrow) and pull out selector shaft with gear shift pedal.

Note:

Headless screw is secured with Loctite.

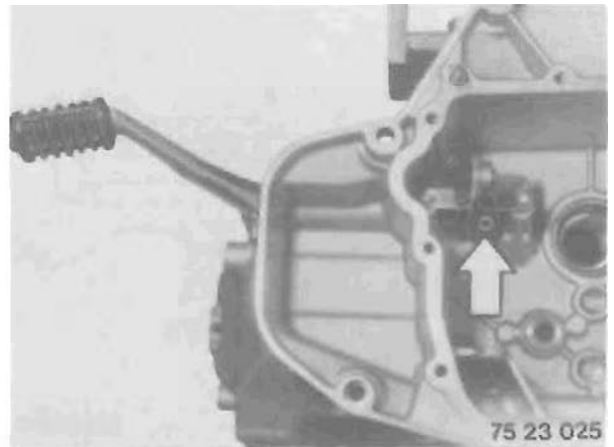

Shift segment – removing

Remove circlip rings (arrows) for stop (2).
Take out segment (1) with torsion spring and stop (2).

Note:

Note washer between torsion spring and housing.

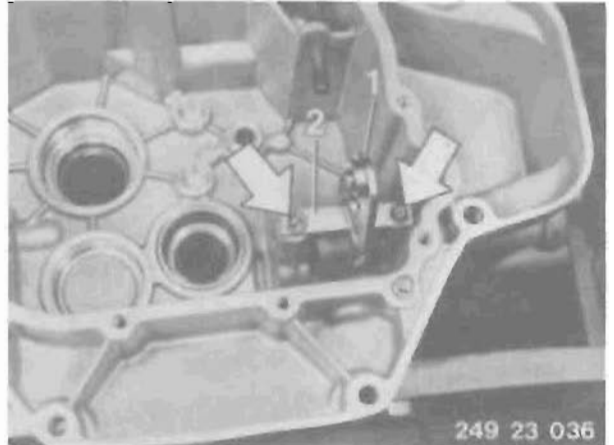

Stop lever – removing and installing

Lift the arm of the spring (arrow) over stop (1) and release torsion spring.

Remove circlip (2) and pull off stop lever. Install by following the same procedure but in the reverse sequence.



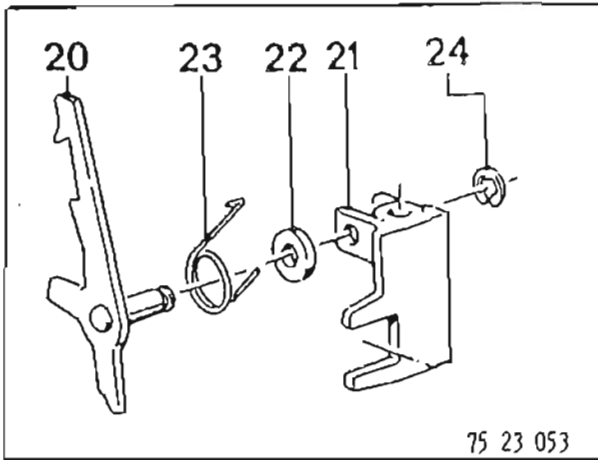

Selector pawl – stripping down

Remove circlip (24).
Pull pawl (20) out of pawl holder (21) together with torsion spring (23) and shim (22).

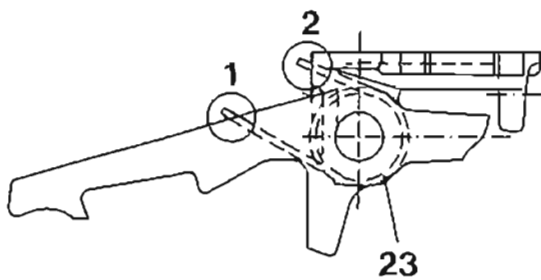

Selector pawl – assembling

Place shim (22) on the pin (arrow) of the pawl (20).
Locate torsion spring (23) with angled section (circle 1) on the straight side of the pawl.
Attach the pawl holder (21) on the pin in such a way that the spring arm makes contact with the indentation (circle 2) on the pawl holder.
Fit circlip (24).

75 23 041

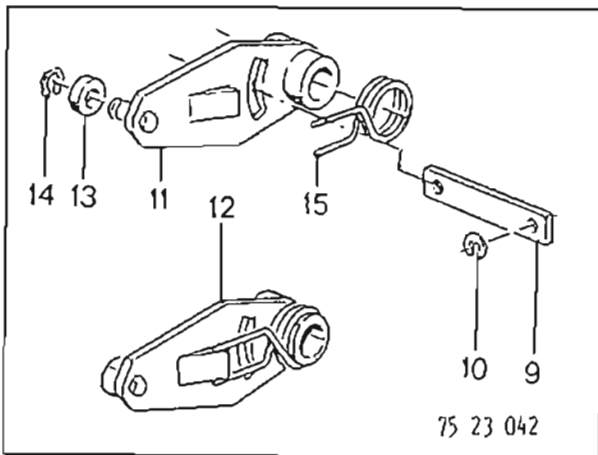

Shift segment – stripping down

Remove torsion spring (15) and stop (9).
Remove circlip (14) and take off pulley (13).
Install by following the same procedure but in the reverse sequence.

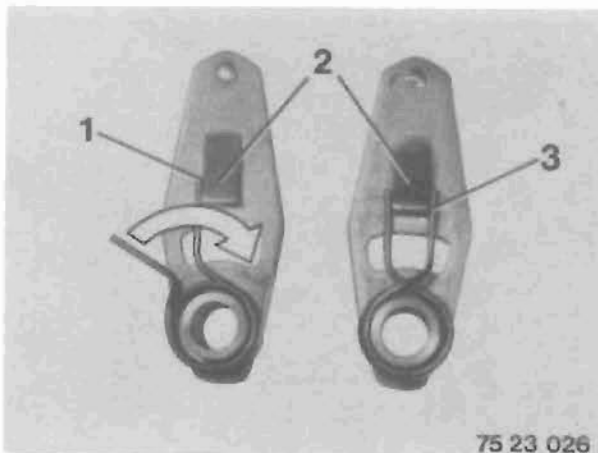

Shift segment – assembling

Place pulley (13) on segment pin (11) and secure with circlip (see illustration above). Allow lower arm (1) of spring to lie in cutout (2) (see illustration on left).
Stretch upper arm (3) over cutout with screwdriver (see illustration on right).

Shaft sealing ring for output shaft – removing

Knock out shaft sealing ring with arbor from the inside.

Note:

Only install again after measuring the frictional coefficient.

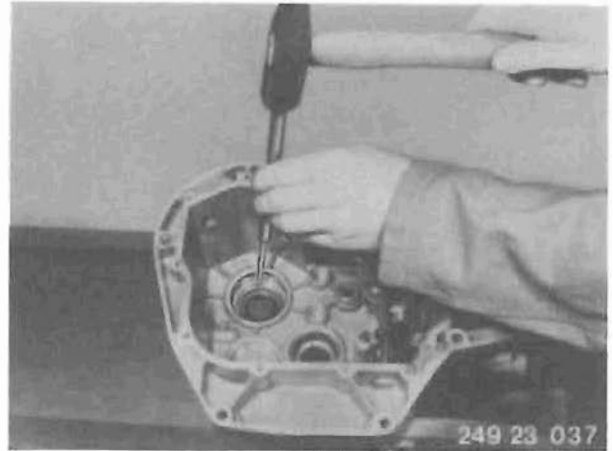

Bearing shell for input shaft taper roller bearings – removing

Remove bearing shell with Kukko puller, BMW 00 8 570 and internal puller BMW 00 8 551.

Pull out bearing shell in cover in a similar manner.

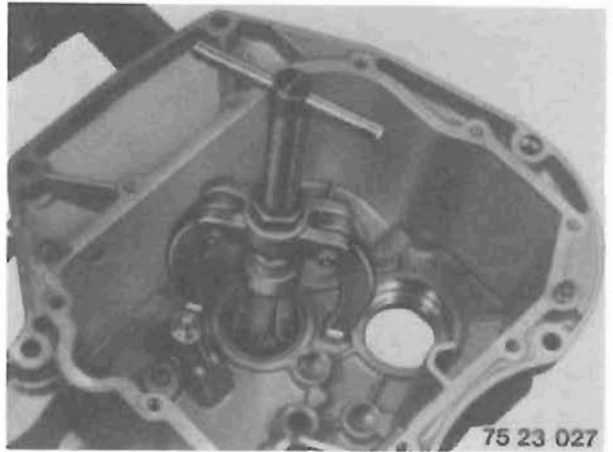

Bearing shell for input shaft taper roller bearings – installing

Heat up bearing seat for taper roller bearings in the housing and cover to app. 80°C (check with thermochrome pin) and insert bearing shell.

Intermediate shaft ball bearings – removing and installing

If faulty, the complete intermediate shaft should be renewed. Pull off the ball bearings (arrows) with universal pullers, BMW 00 7 500.

Heat the ball bearings up to app. 80°C and fit.

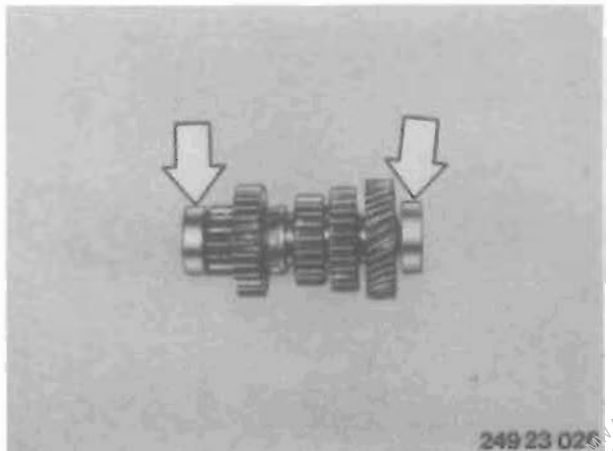

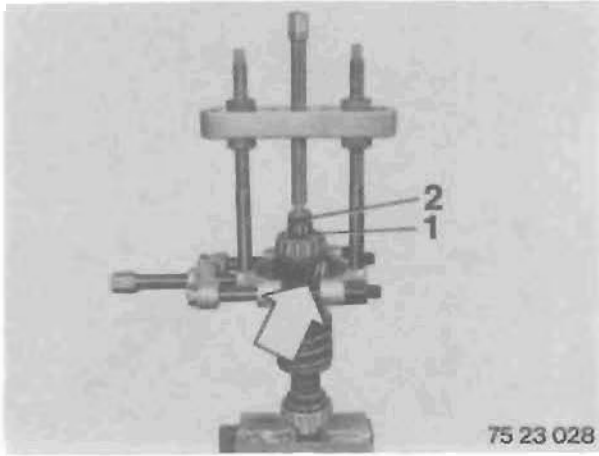

Input shaft – stripping down

Pull off the taper roller bearing and spur gear.
 Secure the hub profile of the input shaft in a vice with protective jaws. Remove the circlip (1).
 Apply universal puller, BMW 00 7 500 in conjunction with thrust head (2), BMW 23 2 670, beneath the spur gear and pull off the taper roller bearing.

Take off thrust piece (8), coil spring (7) and washer.

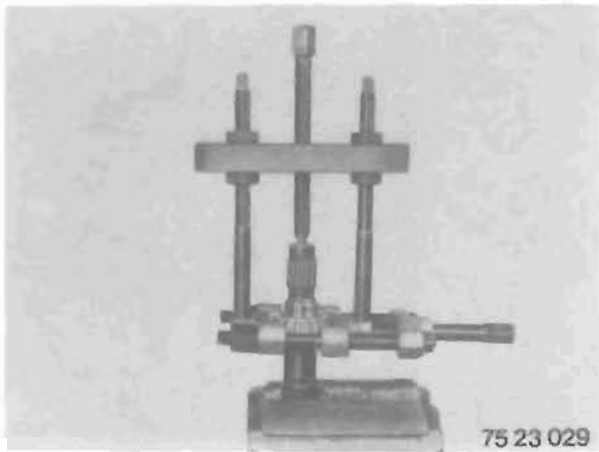

Pull off the taper roller bearing.
 Secure the spur gear hub profile of the input shaft in a vice with protective jaws.
 Pull off the taper roller bearing as described above.

Note:
 Note shims.

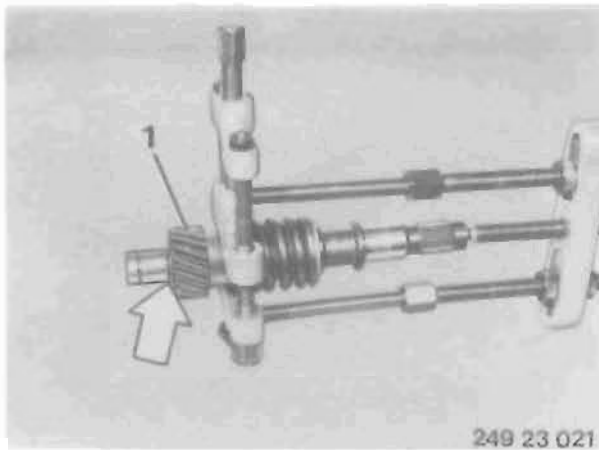

Input shaft – assembling

Fit the washer (6) and coil spring (7).
 Fit the thrust piece (8) and spur gear (9) over the toothed shaft profile.
 Compress the coil spring at the thrust piece in the position shown with universal puller BMW 00 7 500 and pressure head (circle) BMW 23 2 670 until the second groove (arrow) can be seen entirely in front of the spur gear (9).

Clamp input shaft with puller in vice. Heat the taper roller bearing to app. 100°C and install, driving the bearing down with a suitable tube if necessary.

Fit circlip (11) in the upper groove.
 Fit universal pullers beneath the spur gear and push the taper roller bearing up until it meets the circlip.

Note:
 To avoid measuring errors when fitting spacers, there must be no gap between the bearing (10) and circlip (11).
 Remove the universal puller.

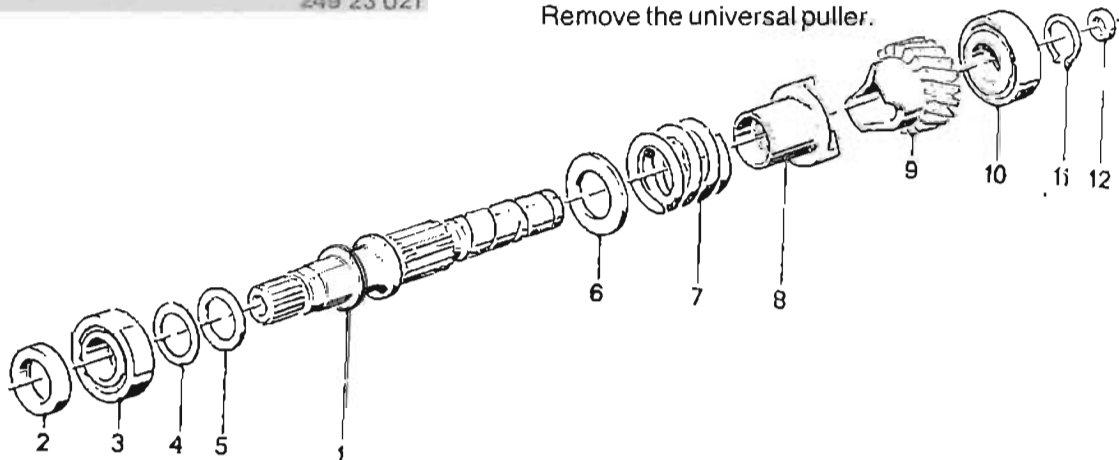

Before stripping down output shaft

Measure end play with feeler gauge

Spur gear, 1st speed: max. 0.30 mm

Spur gear, 2nd speed: max. 0.60 mm

Spur gear, 5th speed: max. 0.40 mm

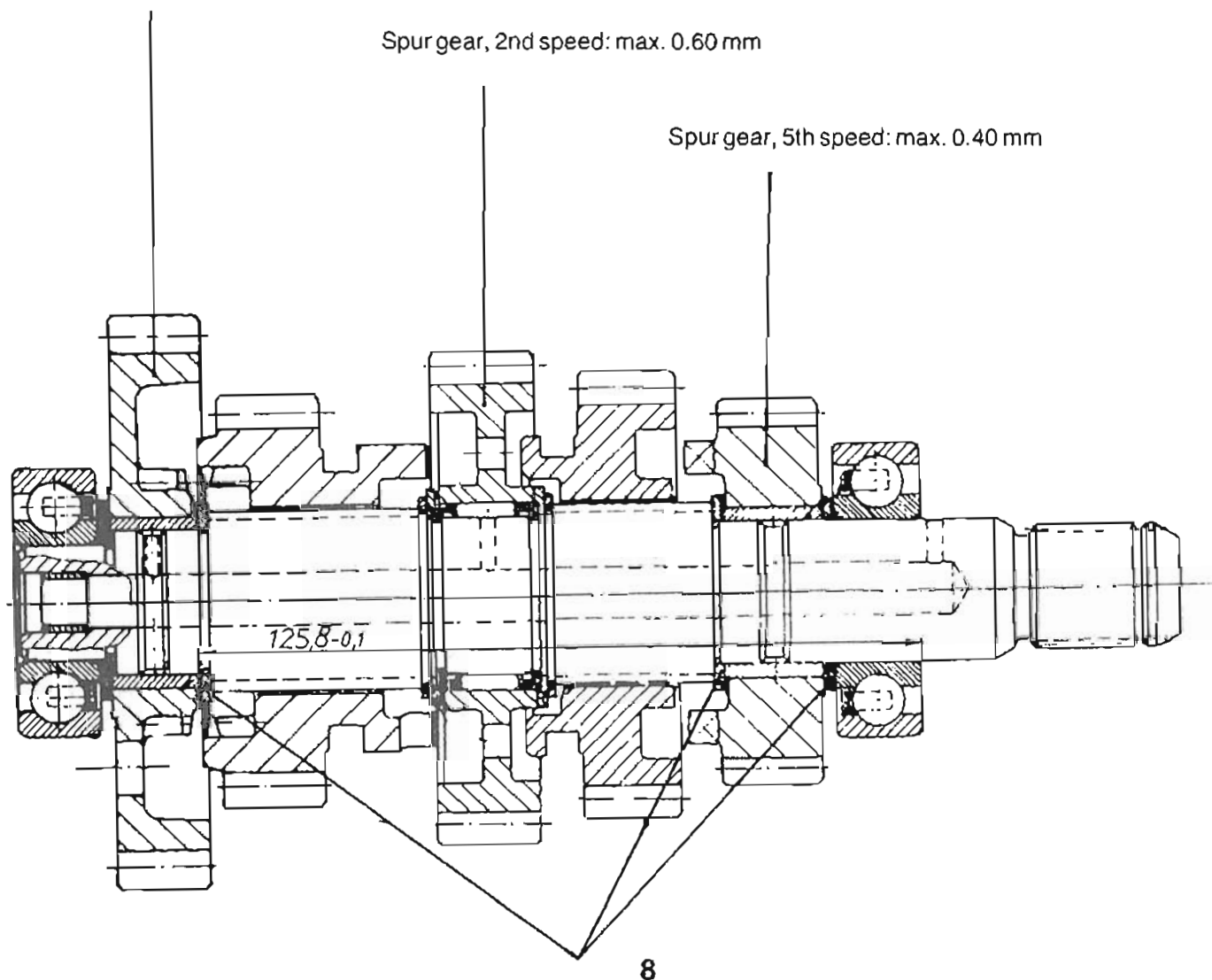

Adjust end play at shims (8)

Shim thicknesses available:
1.6/1.7/1.8/1.9/2.0 mm

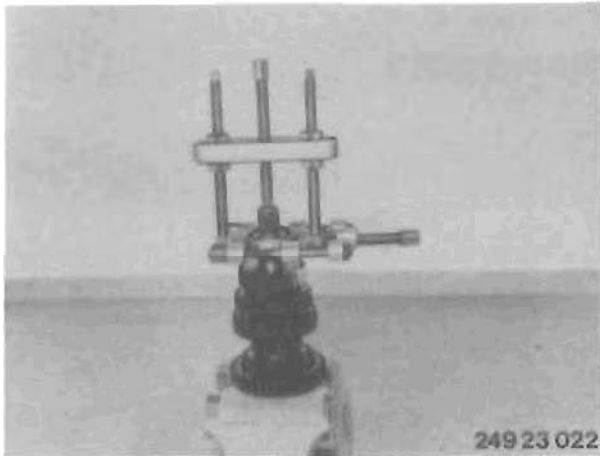

Output shaft – stripping down

Before stripping down, measure output shaft end play with a feeler gauge (see illustration).

Secure the output shaft in a vice with universal puller BMW No. 00 7 500.

Note:

Pull off the rear taper bearing with thrust head BMW 23 2 670.

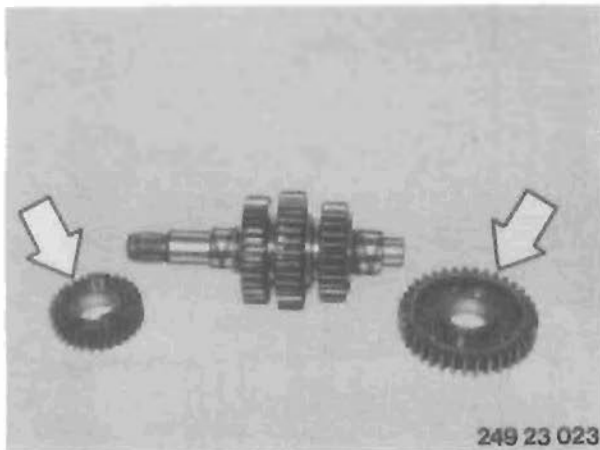

Pull the spur gears (arrows) for 1st and 5th off the bushings (1).

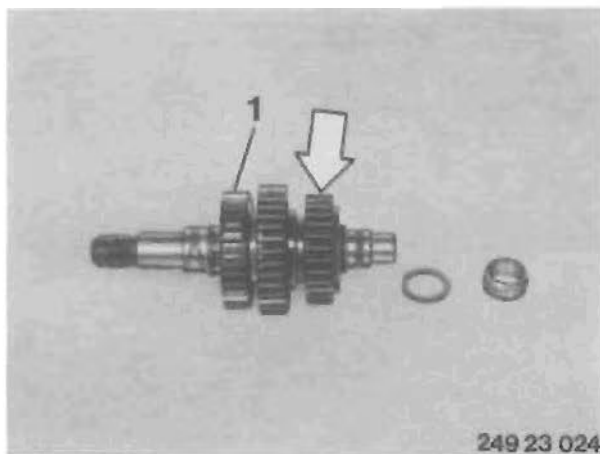

Heat the short spur gear bushing (1st gear) (1) to app. 80°C and pull it off together with the spur gear for 4th and the supporting ring (3).

Heat the long spur gear bushing for 5th gear (1) to app. 80°C and pull it off together with the spur gear for 3rd (arrow) and supporting ring (2).

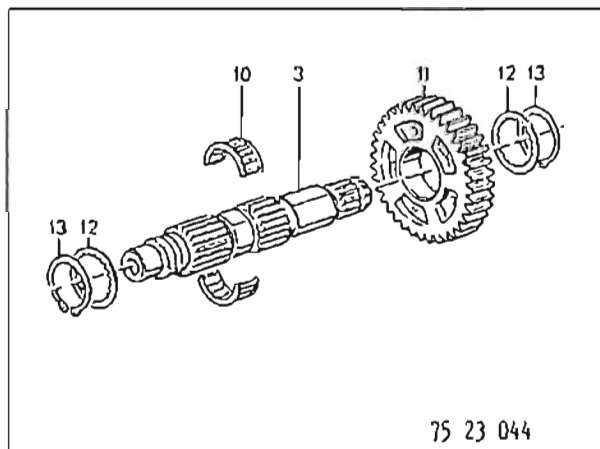

Remove circlip (13) and washer (12).

Pull off the spur gear for 2nd (11).

Take off the split needle roller cage (10).

Remove circlip (13) and washer (12).

Output shaft – installing

(Spur gear for 2nd gear)

Secure output shaft at hub profile (arrow) in vice with protective jaws. Assemble circlip (13) and washer (12). Fit the split, lubricated needle roller cage (10) on the output shaft.

Fit the spur gear for 2nd (11) in such a way that the dogs point downwards.

Assemble the washer with toothed hub profile (12) and circlip (13).

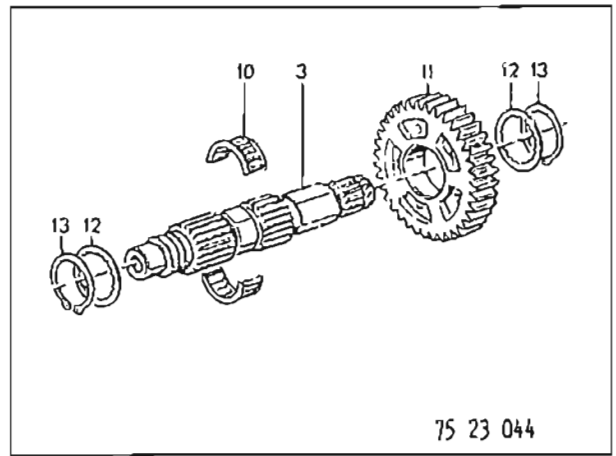

(Spur gear for 3rd gear)

Fit the spur gear for 3rd (14) in such a way that the dogs point upwards.

Fit the shim (8).

Heat up short bushing (15) to app. 80°C and install.

(Spur gear for 5th gear)

Fit the spur gear for 5th (16) in such a way that the dogs point upwards.

Fit the shim (8).

Heat up the ball bearing (17) to app. 80°C and install.

Turn round the output shaft and clamp in the vice with protective jaws at the hub profile to the drive shaft.

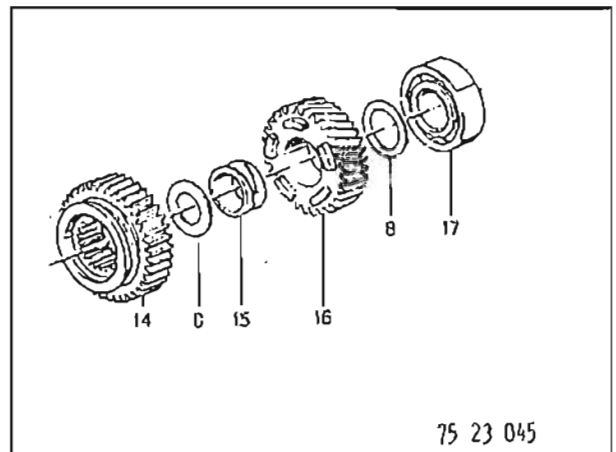

(Spur gear for 4th gear)

Fit the spur gear for 4th (9) in such a way that the dogs point downwards.

Fit the shim (8).

Note:

Longitudinal dimension $x = 125.8 - 0.1$ mm

Adjust with shims (8).

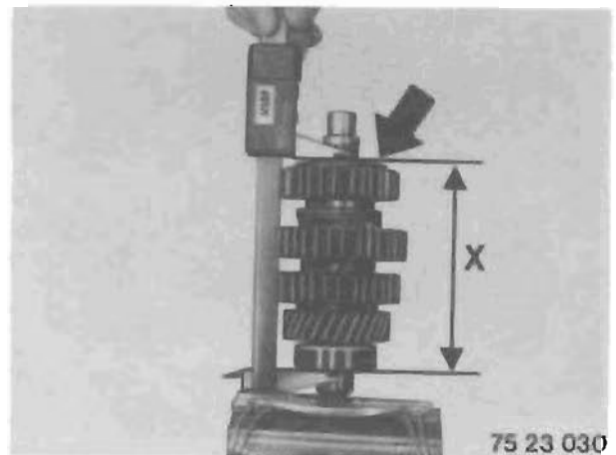

(Spur gear for 1st gear)

Heat up long bushing to app. 80°C and fit.

Fit the spur gear for 1st (6) in such a way that the dogs point downwards.

Fit the shim (5).

Heat up roller bearing (4) to app. 80°C and assemble.

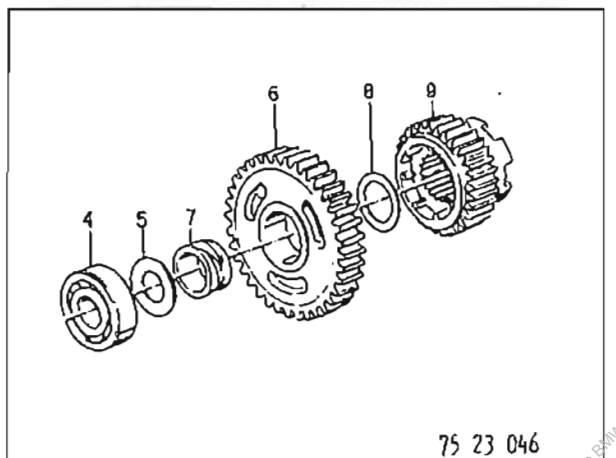

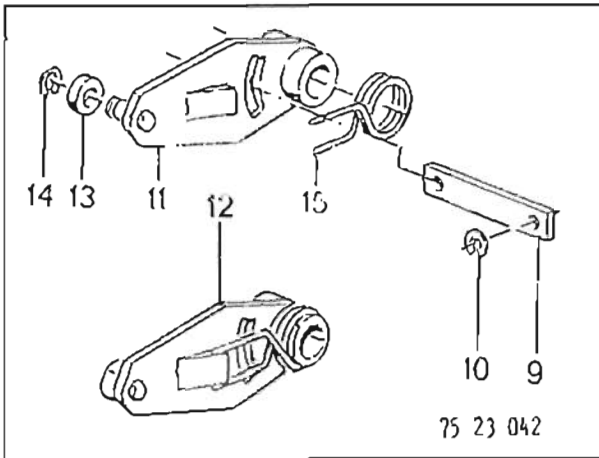

Gearbox – assembling

Note installation instructions.

Lubricate bearing points with SAE 90 hypoid oil.

Install the segment.

Insert the segment (11) in the gear housing with spring (15) and stop (9) (see also next illustration).

Note:

Insert washer between spring (15) and gear housing.
Insert guide groove in segment on the pin in the base of the housing.

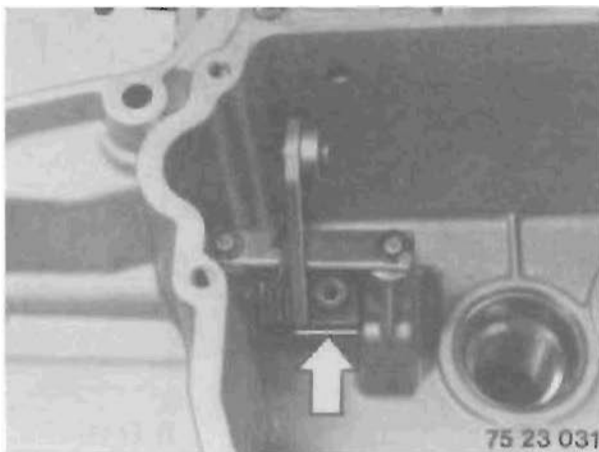

Selector shaft – installing

Introduce the selector shaft until the selector shaft bore in the threaded bore of the segment is visible.

Secure headless screw (8) with Loctite 242.

Fix the stop (9) with circlips (10).

Tightening torque:

Headless screw

$17 \pm 2 \text{ Nm}$

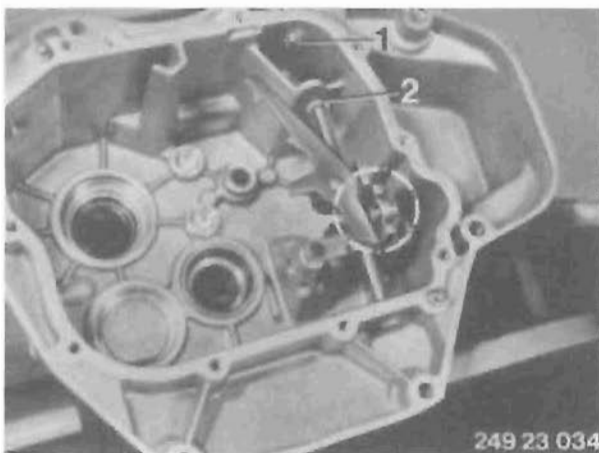

Selector pawl – installing

Install the pawl so that the segment roller engages in the guide lug on the pawl holder (circle).

Introduce guide rod through breather bore (1) and secure with circlip (2).

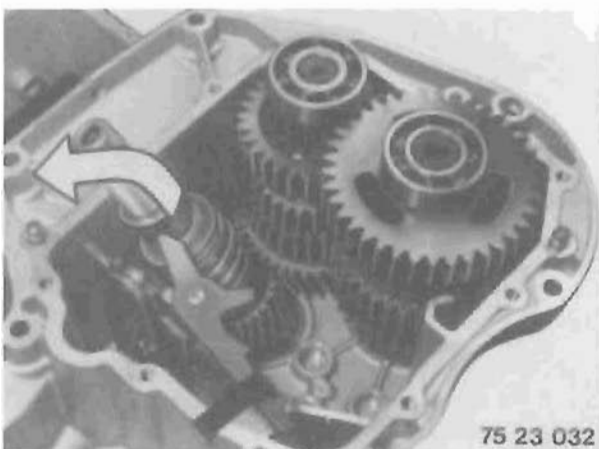

Gearbox shafts – installing

Heat up gear housing to app. 80°C (check with thermochrome pin) and insert bearing shell.

Insert input shaft and push away in the direction of the arrow.

Insert the output and intermediate shafts in the warm housing.

Selector forks – installing

Insert selector fork for 5th (identified by cutout) into the output shaft spur gear with the short guide end upwards.
Insert selector forks for 1st and 2nd (2) into the output shaft spur gear with the short guide end downwards.
Insert selector forks for 3rd and 4th (4) (narrow, elongated shape) into the intermediate shaft spur gear with the short guide end downwards.

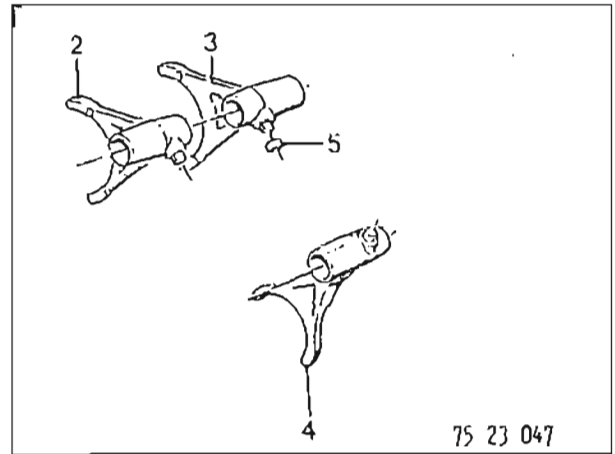

Selector drum – installing

Engage pawl in housing wall with clamping device for chain tensioner BMW 11 5 500.
Press back input shaft and selector forks in the direction of the arrow.

Note:

To prevent the rollers from falling, locate them on the selector fork guide journals.

Insert the selector drum (2) in such a way that the idle position stop points towards the segment (dotted line).

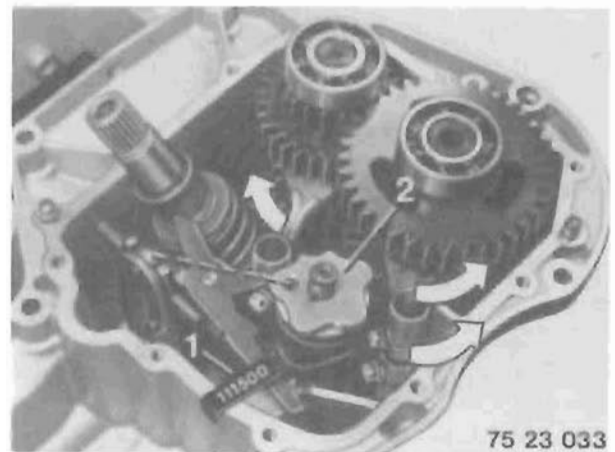

Pivot the selector fork for 5th gear (3) inwards and introduce the guide journal in the selector drum.
Pivot the selector forks for 1st and 2nd gears (2) inwards and introduce the guide journals in the selector drum.

Note:

To facilitate assembly, raise spur gears for 1st and 2nd slightly with an angled screwdriver (or wire hook etc.).

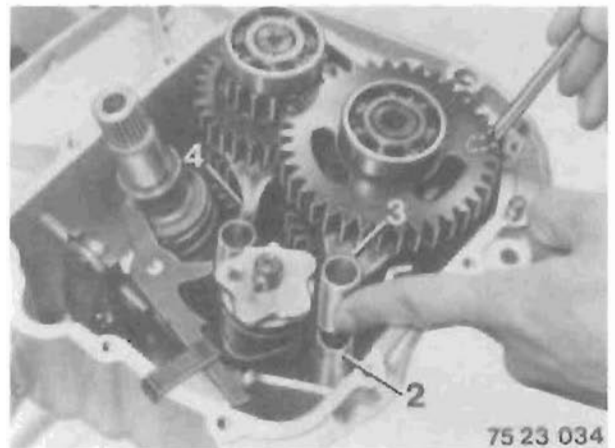

Pivot selector forks for 3rd and 4th (4) inwards and introduce the guide journals in the selector drum.

Install the lubricated selector fork shafts.
Remove the clamping device on the pawl.
Turn the input shaft to the centre position.

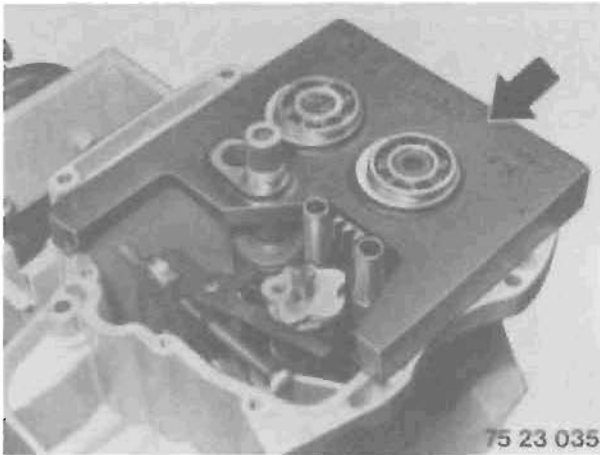

Gearbox shafts – spacing out

In order to calculate axial play (endplay) exactly, place BMW measuring plate 23 1 660 (arrow) on the gear housing to guide the shafts.

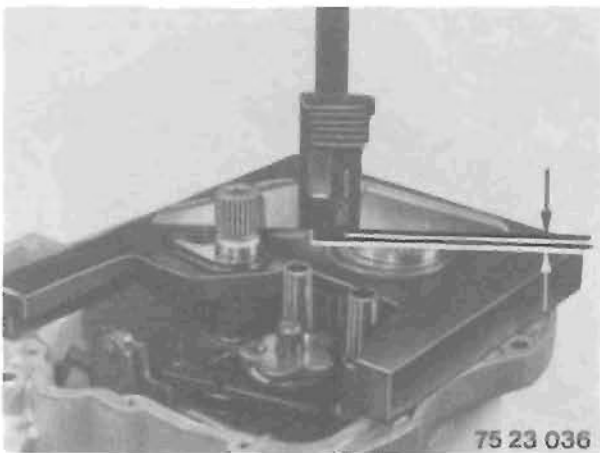

Using a depth gauge, measure the gap between the roller bearing external race and the measuring plate. Only measure the output and intermediate shafts in this way.

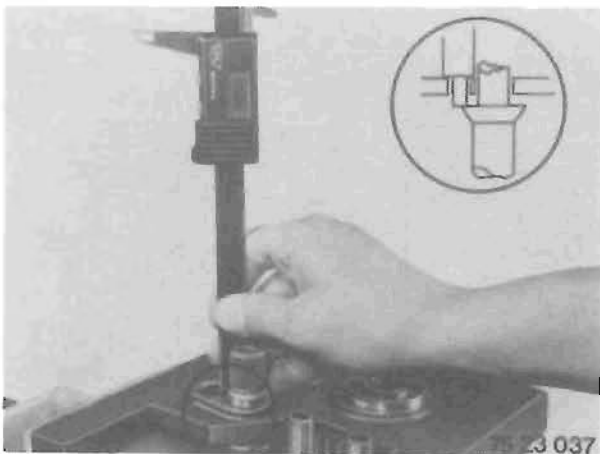

On the input shaft, measure through the window (arrow) in the measuring plate up to the bearing shoulder on the shaft and note the value.

Record this value, preceded by a negative sign (–), in the table (see page 23–41.0).

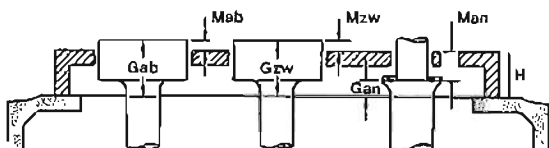

$M_{ab} \hat{=}$ App. dimension from the output shaft to the measuring plate

$M_{zw} \hat{=}$ App. dimension from the intermediate shaft to the measuring plate

$M_{an} \hat{=}$ App. dimension from the measuring plate to the input shaft shoulder

$H \hat{=}$ Height of measuring plate

Overall dimensions:

$$G_{ab} = M_{ab} + H$$

$$G_{zw} = M_{zw} + H$$

$$G_{an} = H - M_{an}$$

75 23 079

Measure the distance from the gearbox cover joint face to the base of the bearing seat in the cover.
(Output and intermediate shafts only!)

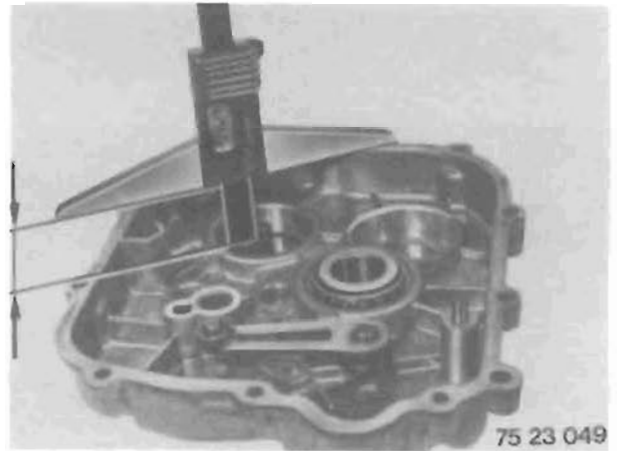

Measure the input shaft with the taper roller bearing installed.
Measure the distance from the gearbox cover joint face to the internal bearing race.
It is recommended to record these measurements in a table as shown below.

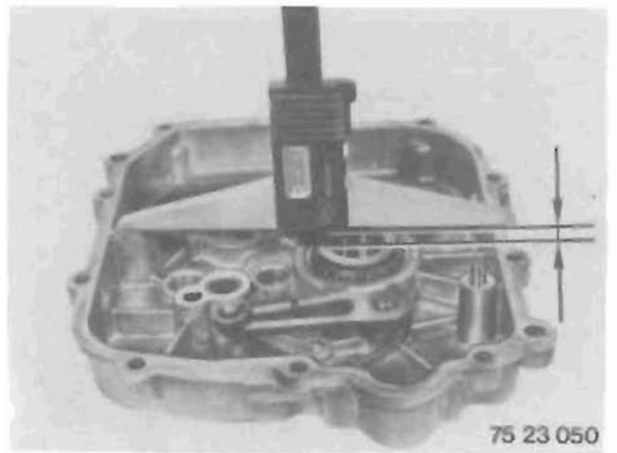

D_{ab} ≙ Cover dimension, output shaft
 D_{zw} ≙ Cover dimension, intermediate shaft
 D_{an} ≙ Cover dimension, input shaft

Permitted endplay for intermediate and output shafts:
Endplay = 0.05 ... 0.15 mm

Permitted input shaft preloading:
Preloading = 0.03 ... 0.08 mm

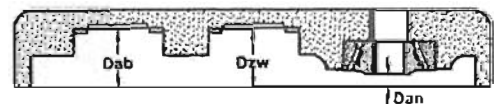

75 23 080

Sample measurements

All dimensions (M) in mm	Output shaft "ab"	Intermediate shaft "zw"	Input shaft "an"
H	30.00	30.00	30.00
▶ + M, measure!	5.45	6.05	⊖ 20.10
= G	35.45	36.05	9.90
▶ D, measure!	36.40	36.90	11.30
- G	-35.45	-36.05	- 9.90
= Endplay without shims	0.95	0.85	1.40
- Permitted endplay	- 0.05	- 0.05	⊕ 0.05
= Shim thickness	0.90	0.80	1.45



Fit a shim of the right size on the input shaft. Heat the taper roller bearing to app. 80°C and install it.

Grease a shim of the right size for the intermediate and output shafts and fit on the ball bearings.

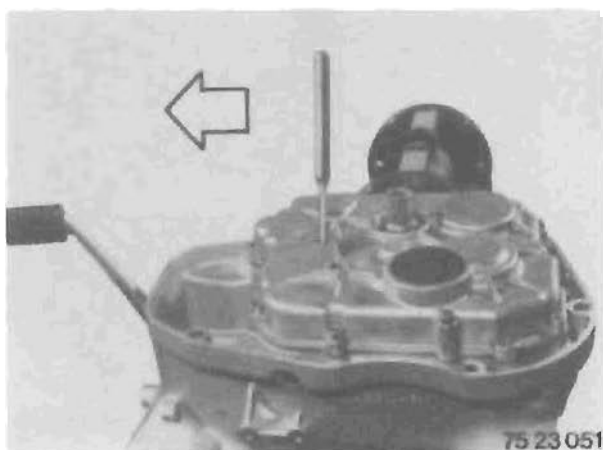

Gearbox cover – installing

Heat the gearbox cover without shaft sealing ring for intermediate and output shaft bearing points to app. 100°C.

Clean the gear housing joining surfaces of oil and grease and seal with a thin coating of Loctite 573.

Push the stop lever in the direction of the arrow with a suitable arbor and carefully assemble the gearbox cover. Tighten the retaining screws.

Tightening torque:

Cover retaining screws

$9 \pm 1 \text{ Nm}$

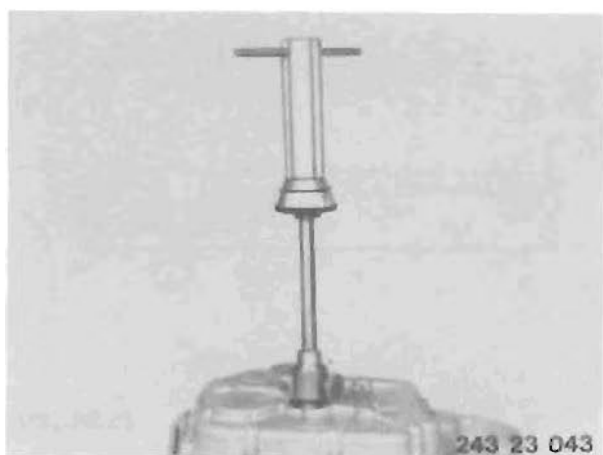

Check the taper roller bearing friction value with BMW adapter 23 6 670 and friction value gauge, BMW No. 00 2 570 at 1 revolution per second.

When checking, the radial sealing rings must be removed from the input and output shafts.

Lubricate the bearings with SAE 90 hypoid oil.

Friction value (preloaded):

0.03 mm $\hat{=}$ app. $0.19 \pm 0.02 \text{ Nm}$ $\hat{=}$ app. $1.9 \pm 0.02 \text{ kpcm}$

0.055 mm $\hat{=}$ app. $0.34 \pm 0.02 \text{ Nm}$ $\hat{=}$ app. $3.4 \pm 0.02 \text{ kpcm}$

0.08 mm $\hat{=}$ app. $0.50 \pm 0.02 \text{ Nm}$ $\hat{=}$ app. $5.0 \pm 0.02 \text{ kpcm}$



Shaft seal ring in gearbox cover – installing

Drive in the shaft sealing ring with BMW arbor 23 1 770 (arrow) and handle, BMW No. 00 5 500, until the arbor is in full contact.

Drive in the sealing cover (arrow).
 Install the neutral stop (ball and spring).
 Tighten the spring preloading screw (1) with Loctite 242.

Tightening torque:

Spring bearing screw $13 \pm 2 \text{ Nm}$

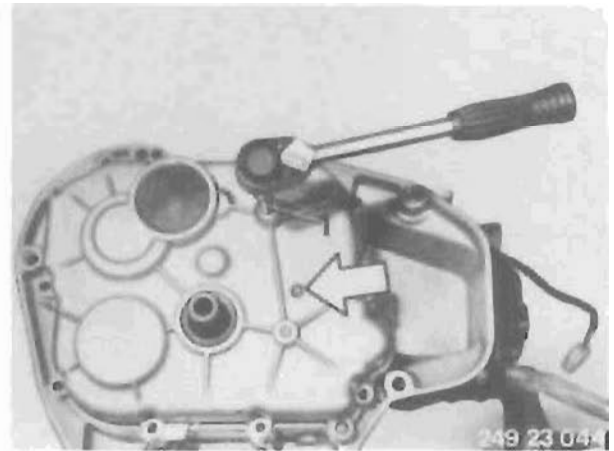

Shaft sealing ring for output shaft – installing

Drive in the sealing ring with BMW arbor 23 1 760 and handle, BMW No. 00 5 500, until the arbor is in full contact.

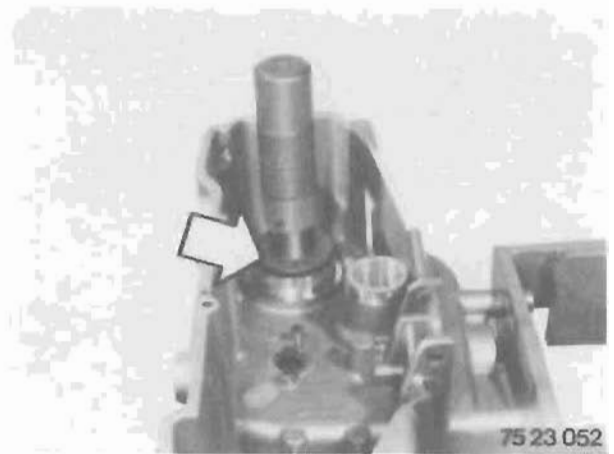

Pedal switch – removing and installing

Slacken off and remove retaining screw (3) and pull shift lever off selector shaft.

Install the new pedal switch in such a way that the centre of the slit corresponds to the mark on the selector shaft (see illustration on right).

Tighten retaining screw.

Tightening torque:

Retaining screw $8.5 \pm 1 \text{ Nm}$

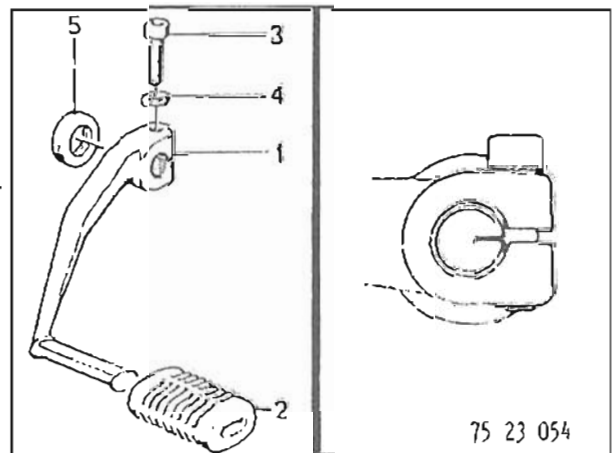

31

Front fork

31 Front fork

Technical data	Page	31-03.0
Tightening torques		31-04.0
Diagrams		31-05.0
Telescopic fork – removing		31-11.0
Telescopic fork – stripping down		31-15.0
Fluidbloc – removing and installing		31-21.0
Taper roller bearings in steering head – removing and installing		31-22.0
Telescopic fork – measuring		31-23.0
Telescopic fork – installing		31-25.0
Steering head tube – installing		31-27.0

Telescopic fork

Specifications

Model	K 75	K 75 c	K 75 s	K 100	K 100 RS	K 100 RT	K 100 LT
Front-wheel castor	mm 101						
Handlebar lock angle to each side	40°		35°	40°	35°		
Spring travel (load 75 kg)	mm 185						
Installed length (test)	mm app. 180						
Fixed tube surface	Hard-chromed						
Fixed tube external Ø	mm $41.4_{-0.075}^{+0.057}$						
Sliding fork tubes	Cast light alloy						
Sliding fork tube interior diameter	mm $41.4_{0}^{+0.039}$						
Sliding tube play on fixed tube	mm 0.050 ... 0.114						
Max. permitted runout of fixed tube	mm 0.1						
Length of fork spring	mm 395^{+6}						
Wire diameter of fork spring	mm 4.7 ± 0.03						
Telescopic fork oil – approved oil grades	<p>Aral P 3441 shock absorber oil Aral 1010 shock absorber oil Bel-Ray-Fork oil with "Seal Swell" SAE 5 PB Aero Hydraulic BP-Olex HLP 2849 Castrol shock absorber oil 1/-318 Castrol DB hydraulic fluid Castrol AWH 15 Castrol LHM, preferably for below 0°C ESSO Univis 13 telescopic fork oil Golden Spectro suspension fluid, very light Mobil Aero HFA shock absorber oil Mobil DTE 11 shock absorber oil Premium fork lubricant, "Spectro SAE 10" competition grade – only for sports riding Shell 4001 shock absorber oil Shell Aero Fluid 4 Wack Chemie, high-performance telescopic fork oil, SAE 5 (red)</p>						
Filling capacity per fork tube	l 0.330 – 0.010		0.280 ± 0.010	0.330 – 0.010	0.360 – 0.010		
Lubricating grease in bushing	Gleitmo 805						

Telescopic fork

Tightening torques

Connection	Nm
Fork stabiliser to sliding tube	21 ± 2
Oil drain plug to sliding tube	9 ± 1
Oil filler plug to spring mounting	15 ± 2
Clamping screw on upper fork bridge	22 ± 1
Clamping screw on lower fork bridge (after fitting lower fork bridge)	43 ± 3
Circular nut	Play-free
* Stop screw	74 ± 5
* Plastic nut, distributor pipe on steering-head tube	10 ± 1
Retaining screw, damper to sliding tube	20 ± 2
Retaining screw for quick-release axle	33 ± 4
Clamping screw for quick-release axle	14 ± 2
Hollow screw for brake line to distributor pipe	7 ± 1
Brake caliper to sliding tube	32 ± 2
Handlebar clamps to fork bridge	22 ± 2
Tapered screw in steering head	9 ± 1
Circular nut	Play-free
** Locking pipe	65 ± 5
** Hext nut, 7 mm deep	65 ± 5
** Locking pipe	45 ± 3
** Hext nut, 5 mm deep	45 ± 3

* on  and K 75 c up to Frame No. 0 113 804

** only on  and K 75 c from Frame No. 0 113 805

Telescopic fork



K 75 c up to Frame No. 0 113 804

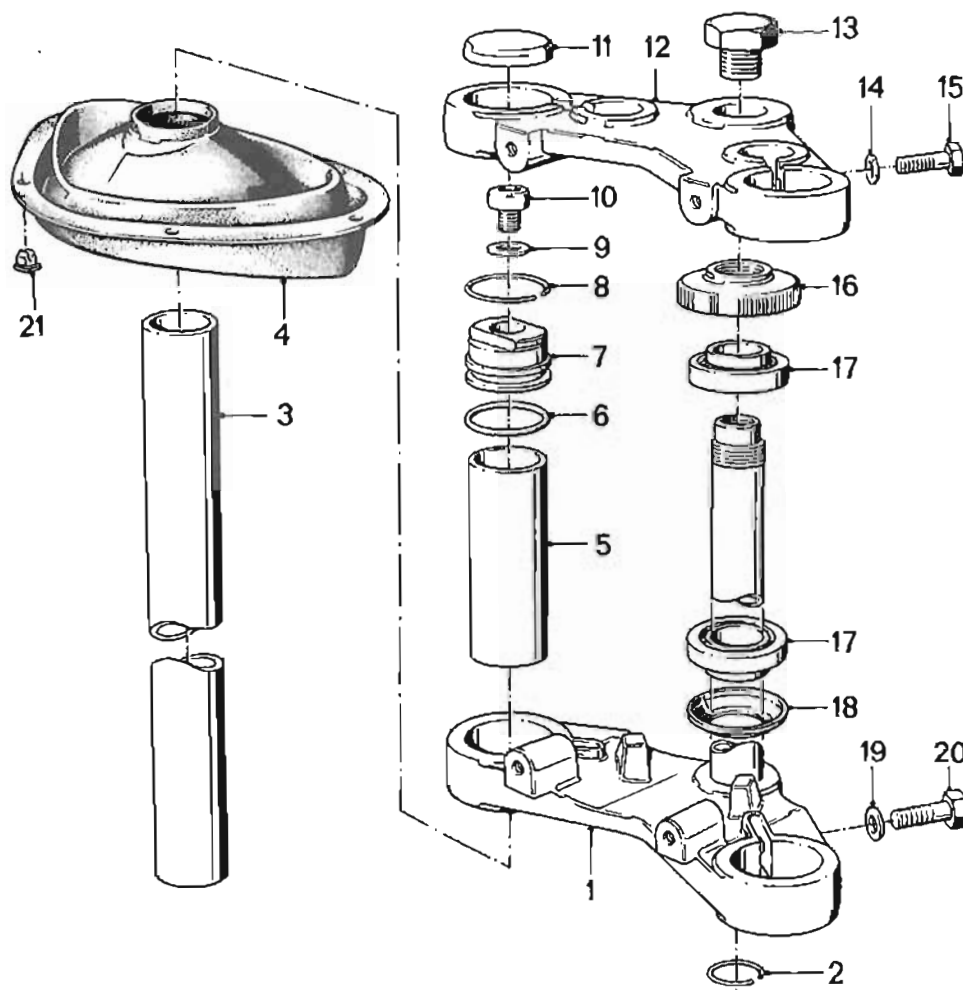

- 1 Lower fork bridge
- 2 Snap ring
- 3 Fixed tube
- 4 Seal (K 100 RS, RT, LT)
- 5 Spacertube
- 6 O-ring
- 7 Spring bearing
- 8 Snap ring
- 9 Sealing ring
- 10 Machine screw
- 11 Cover

- 12 Upper fork bridge
- 13 Bolt
- 14 Washer
- 15 Hex bolt
- 16 Round nut
- 17 Roller bearing
- 18 Ring
- 19 Washer
- 20 Hex nut
- 21 Spreader nut (K 100 RS, RT, LT)

Telescopic fork



K 75 c from Frame No. 0 113 804

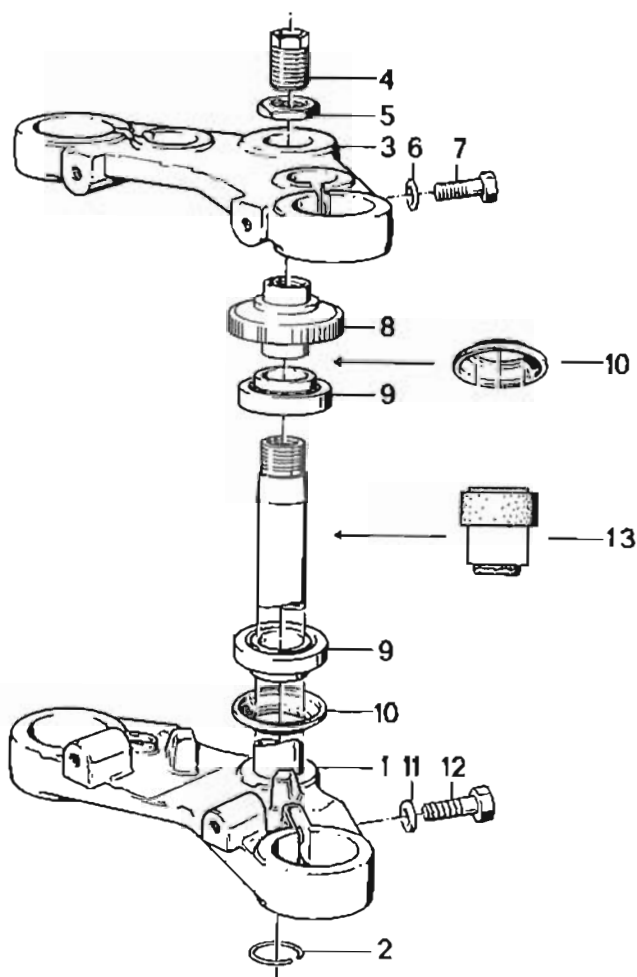

- 1 Lower fork bridge
- 2 Snap ring
- 3 Upper fork bridge
- 4 Locking tube
- 5 Nut
- 6 Washer
- 7 Retaining bolt

- 8 Adjusting ring
- 9 Taper roller bearing
- 10 Ring
- 11 Shim
- 12 Retaining bolt
- 13 Fluidbloc

Telescopic fork

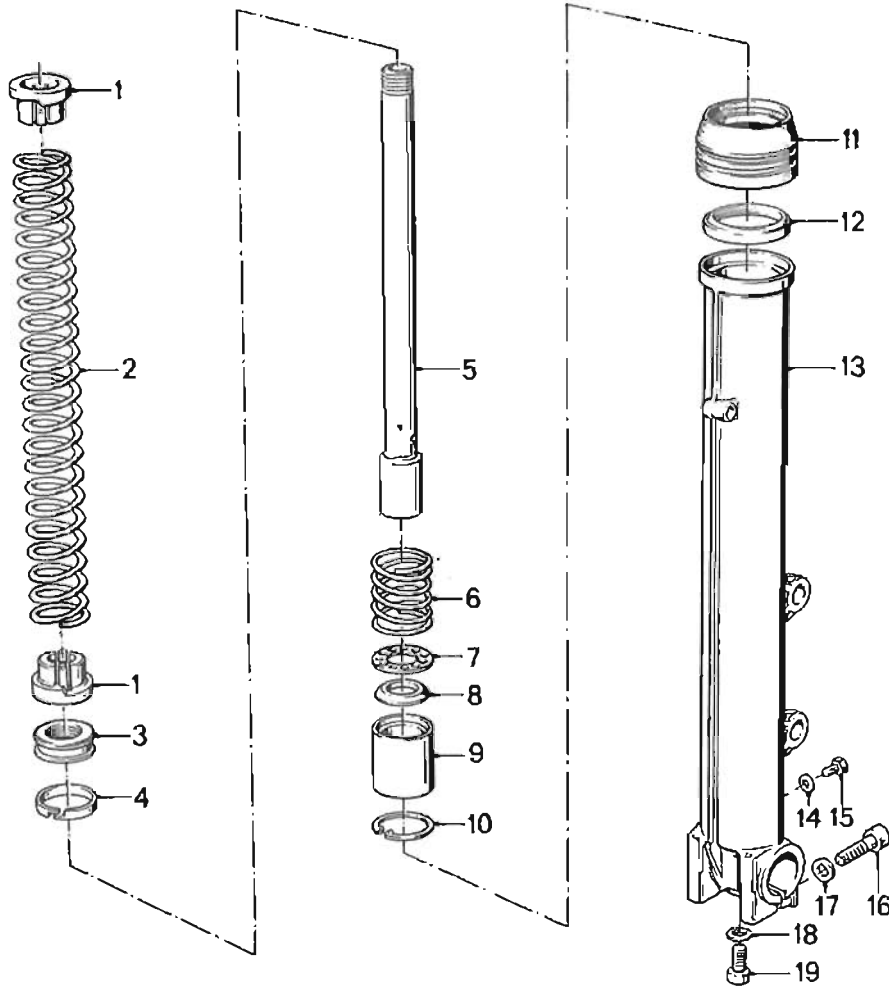

- 1 Spring bearing
- 2 Coil spring
- 3 Piston
- 4 Guide ring
- 5 Damper tube
- 6 Coil spring
- 7 Perforated disc
- 8 Valve disc
- 9 Valve housing
- 10 Circlip

- 11 Bushing
- 12 Sealing ring
- 13 Sliding tube
- 14 Sealing ring
- 15 Hex bolt
- 16 Machine screw
- 17 Washer
- 18 Sealing ring
- 19 Machine screw

Telescopic fork



Standard version with single spring (A) or divided spring (B)

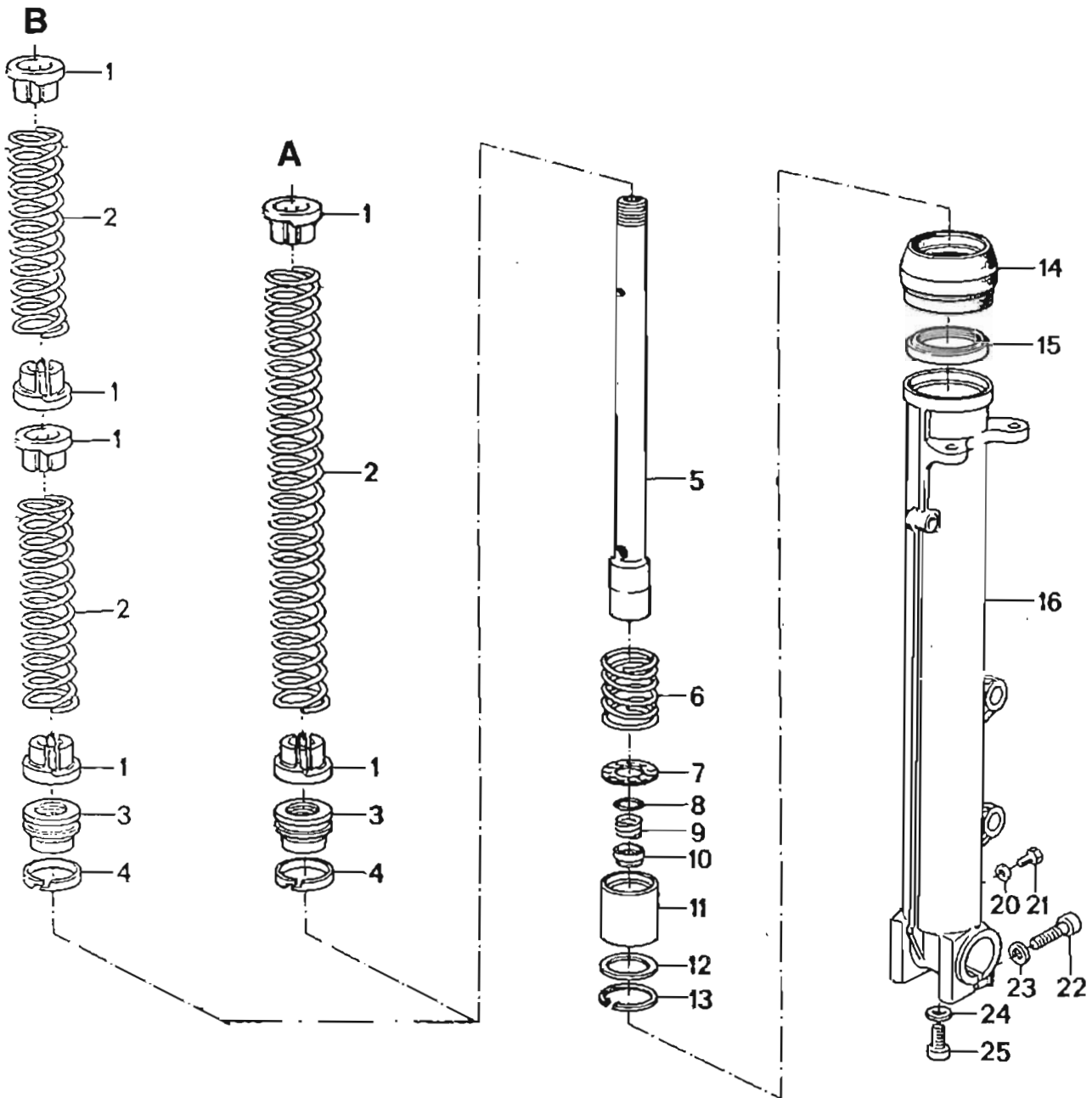

- 1 Spring bearing
- 2 Coil spring
- 3 Piston
- 4 Guide ring
- 5 Damper tube
- 6 Coil spring
- 7 Perforated disc
- 8 O-ring
- 9 Coil spring (soft)
- 10 Valve
- 11 Valve housing

- 12 Spacer ring
- 13 Circlip
- 14 Cap bushing
- 15 Shaft sealing ring
- 16 Sliding tube
- 20 Sealing ring
- 21 Oil drain plug
- 22 Washer
- 23 Clamping screw
- 24 Sealing ring
- 25 Screw

Telescopic fork



Sports version

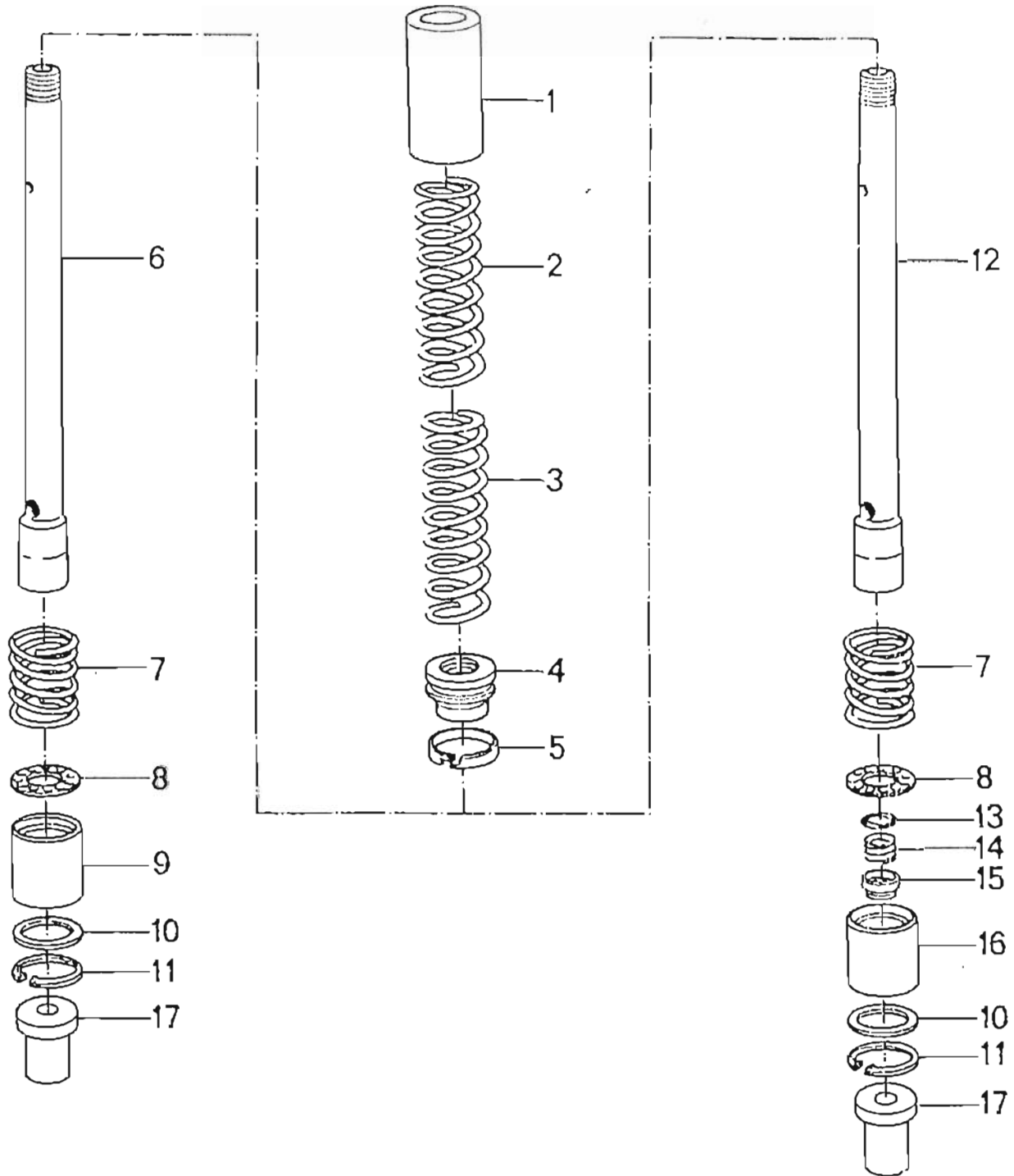

- 1 Spacing tube
- 2 Coil spring
- 3 Coil spring
- 4 Piston
- 5 Guide ring
- 6 Tube, right
- 7 Coil spring
- 8 Valve disc
- 9 Bushing

- 10 Spacer ring
- 11 Circlip
- 12 Tube, left
- 13 Sealing ring
- 14 Coil spring
- 15 Valve
- 16 Valve housing
- 17 Spacer

Section 31

Frontfork Showa type

The only 2-valve K Models that received a really good frontfork are the late K75 bikes. From 8.1991 (produktiondate) this fork is mounted in all K75 models.

Major difference to all other:

- 41,0 mm stanchion diameter, all other 2 valve models have 41,3 mm
- Guide bushes in the stanchion and in the forkslider

Not like all the other worn out Fichtel & Sachs and Brembo type forks :

The Showa fork can be repaired !

For details you've to refer realoem and to the K1100 manual. The Marzocci fork is similar to the Showa .

Changing any 2V K model to Showa type is possible – fork bridge needed as well

Showa 41,0 mm

Brembo "sport fork" 41,3 mm

pos 6: flat on the fork slider
pos 2: upper guide bush

pos 1 is "pulled over" the frok slider
no guide bushes

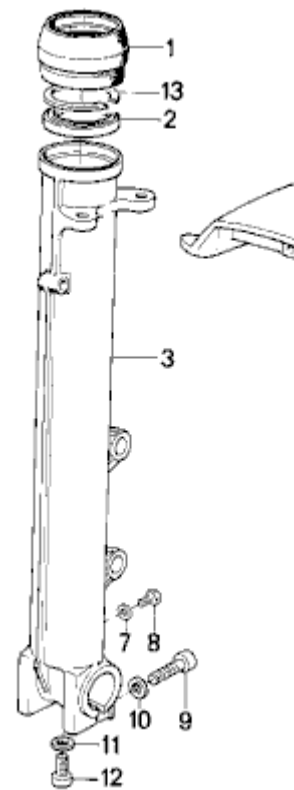
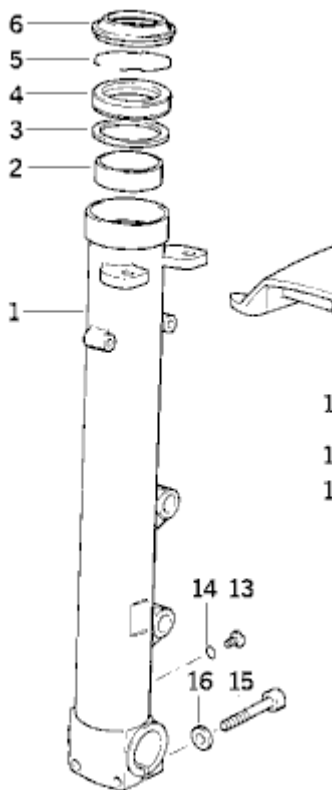

Telescopic fork – removing

K 75, K 100:

Remove headlight fairing with headlight and instrument cluster (see Group 46).

K 75c:

Remove cockpit fairing with headlight and instrument combination (see Group 46).

K 100 RS, RT, LT:

Remove storage compartment and knee pads (see Group 46). Remove lower fairing sections, radiator trim and centre section (see Group 16).

Remove instrument cluster (see Group 62).

Remove fuel tank (see Group 16).

Remove front mudguard (see Group 46).

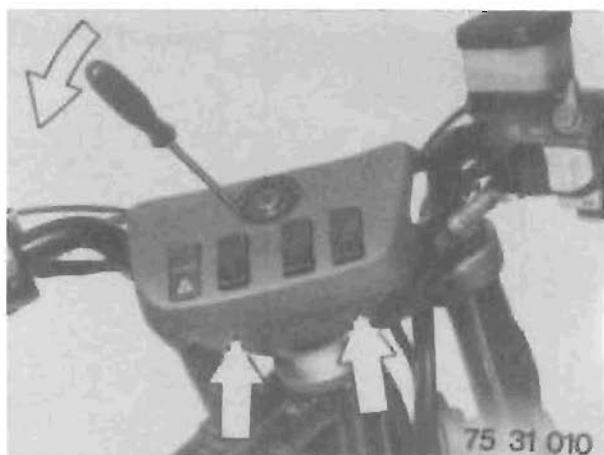

Lever off marked disc for ignition lock with a small screwdriver. Push retaining hooks on either side for ignition lock inwards with a small screwdriver and push the ignition lock down to remove.

Release the retaining screws (arrows) and take off the impact pad.

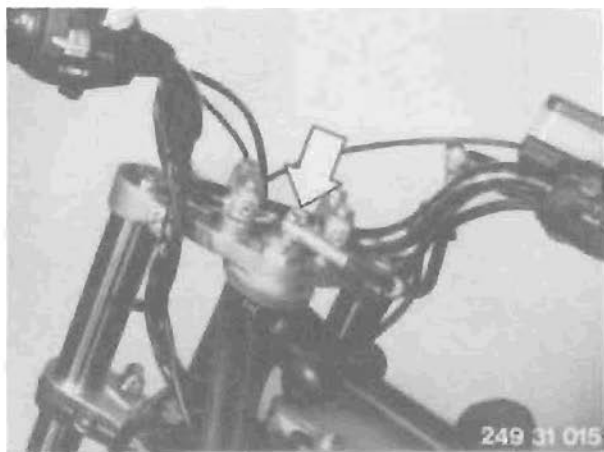

Remove the hollow screw (arrow) for brake hose on the distributor pipe.

Note:

Plug the brake hose.

Warning:

Brake fluid attacks paintwork.



 (K 75 c from Frame No. 0 113 805 on)

Remove clamp (arrow) from distributor pipe and pull the distributor pipe down to remove from steering head tube.

Note:

Plug the top end of the distributor pipe and secure to fixed tube with adhesive tape.

Warning:

Brake fluid attacks paintwork.

●●●● and K 75 c up to Frame No. 0 113 804

Remove plastic nut (arrow) on distributor pipe. Pull distributor pipe down to remove.

Note:

Plug the top end of the distributor pipe and secure to fixed tube with adhesive tape.

Warning:

Brake fluid attacks paintwork.

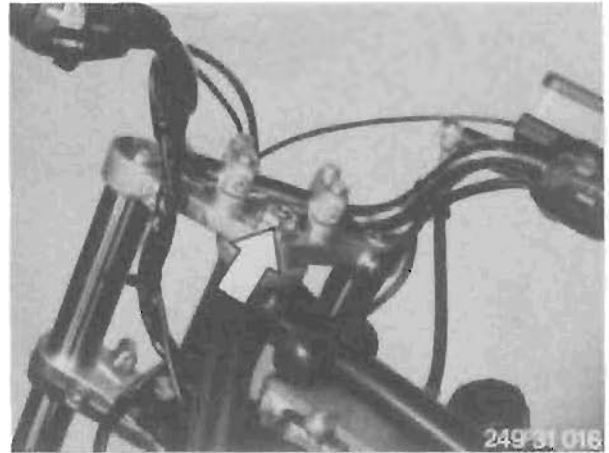

Remove retaining screw (arrows) for handlebar clamps. Set down handlebars with fittings on frame.

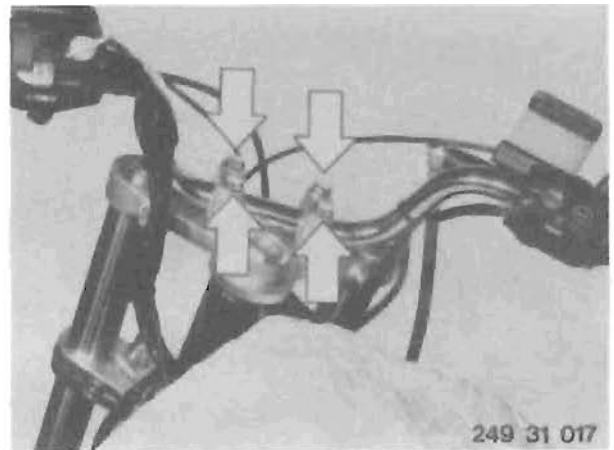

●●●● (K 75 c from Frame No. 0 113 805)

Slacken of clamping screws (arrows), remove hex nut (1) and pull off upper fork bridge.

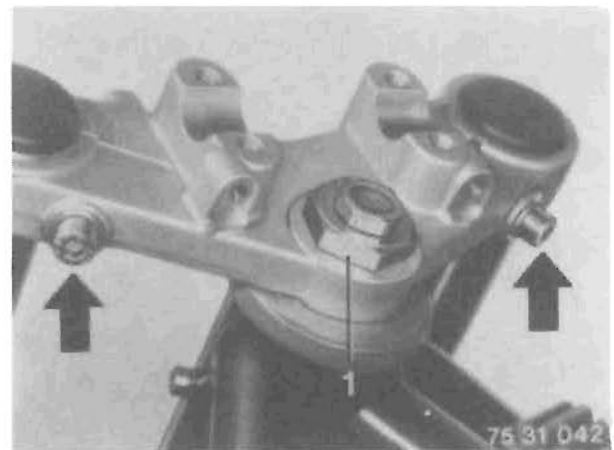

●●●● and K 75 c up to Frame No. 0 113 804

Slacken off clamping screws (arrows), remove stop screw (1) and pull off upper fork bridge. Unscrew round nut on steering head tube.

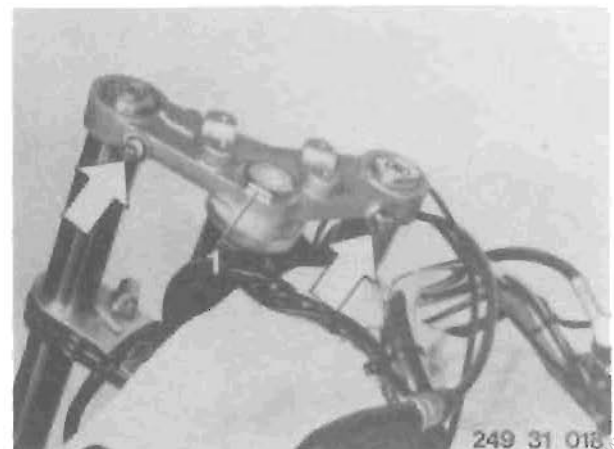

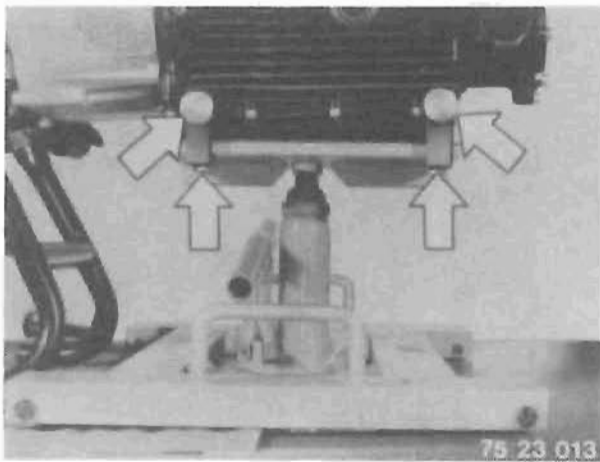

Secure BMW hoist 00 1 510 to oil pan, tighten knurled nuts and hex nuts (arrows). Raise the motorcycle until the front wheel is suspended freely. Remove the front wheel (see page 36–06.0).



 and K 75 c up to Frame No. 0 113 804

Tap with a plastic-headed hammer to push the telescopic fork down until the upper bearing is exposed. Take out the bearing.



Pull down the telescopic fork to remove.

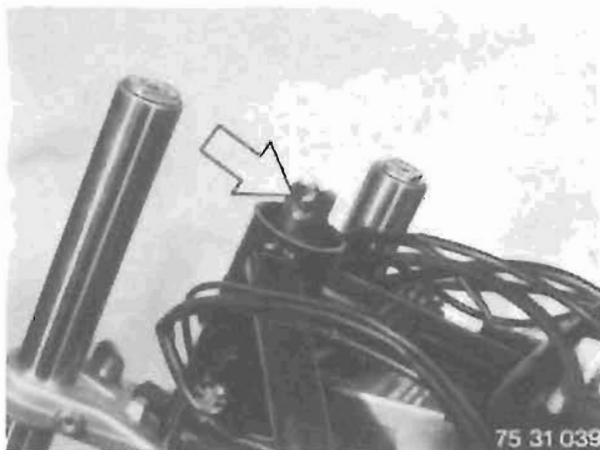

K 75 c up to Frame No. 0 113 804

In order to avoid damaging the fluidbloc, mask over the thread on the steering head tube with 1 1/2 layers of adhesive tape.

Pull down the telescopic fork to remove.

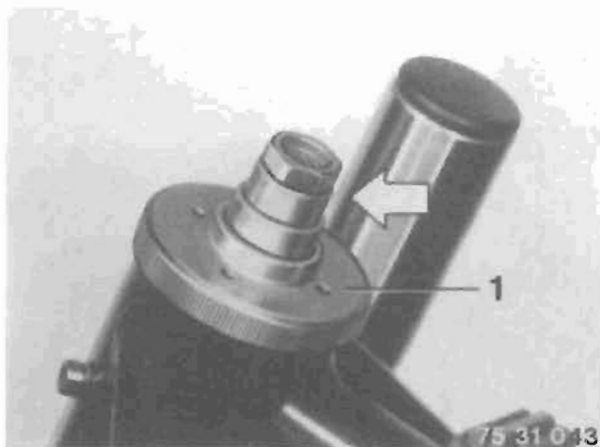

 (K 75 c from Frame No. 0 113 805)

Slacken off locking tube (arrow), unscrew adjusting ring (1) on steering head pipe and simultaneously pull down telescopic fork to remove.

Telescopic fork – stripping down

Models with fork stabiliser

Remove retaining screws (arrows) on fork stabiliser and take off fork stabiliser.

Slacken off retaining screws (1) on lower fork bridge and pull out the fixed tube together with the sliding tube.

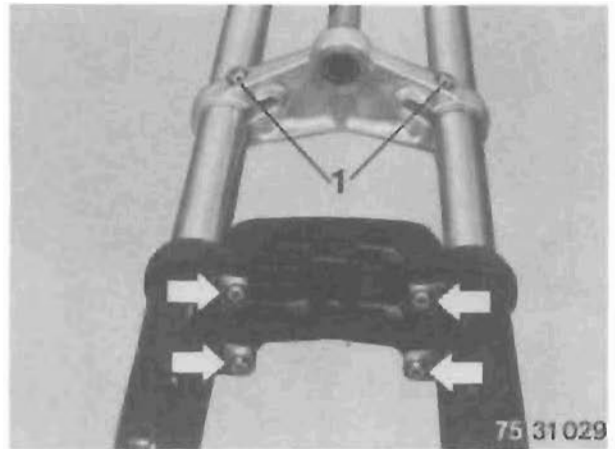

Clamp fixed tube at a slight angle in a vice using BMW wooden block 31 4 600 (arrow).

Open drain plug (1) to drain off oil in telescopic fork.

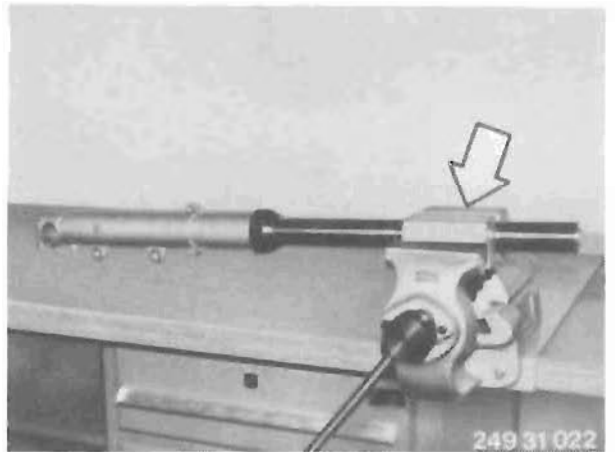

Remove retaining screw for damper in sliding tube. Use the quick-release axle to counter-lock.

Note:

Do not re-use the sealing ring.

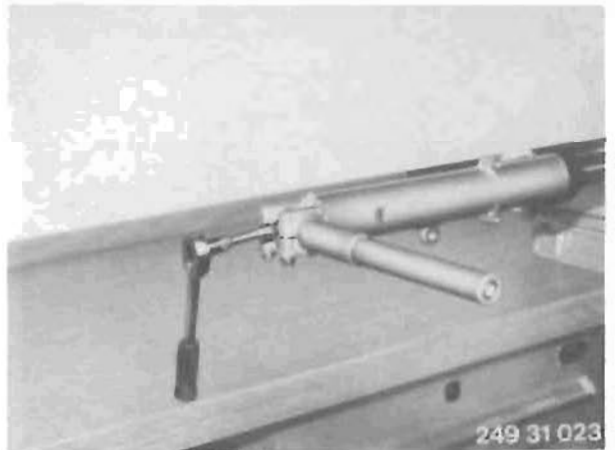

Remove the cover and press in the spring bearing with a suitable screwdriver until the snap ring is visible. Lever out the snap ring with a small screwdriver. Take out the spring bearing, spacer tube and coil spring with spring bearing.

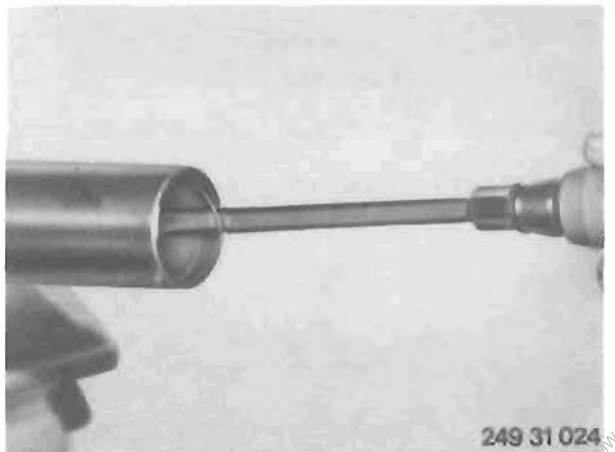

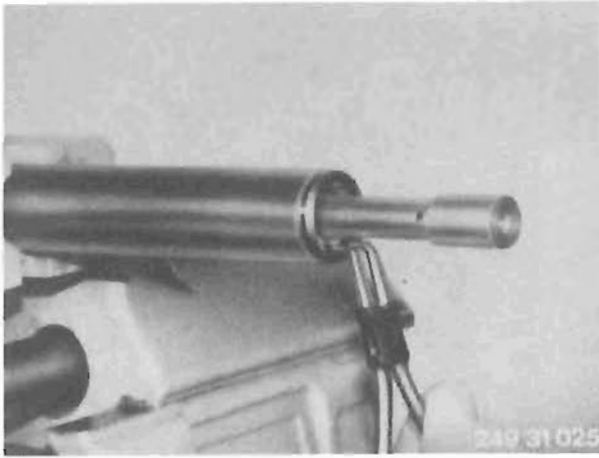

Take out snap ring with pincers.
Pull complete damper out of fixed tube.

Note:
Note spacer rings.

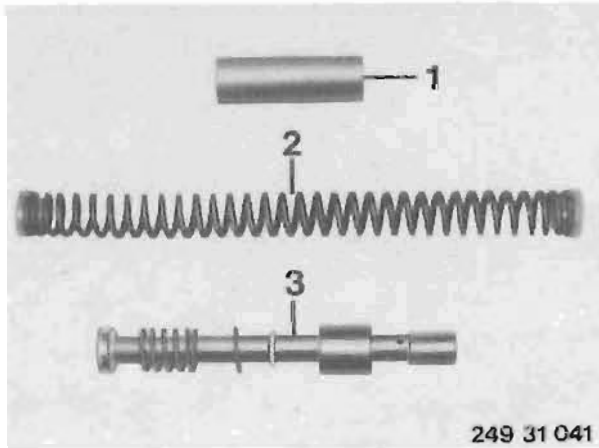

Telescopic fork 
Damper with valve disc

1. Spacer tube
2. Coil spring
3. Damper

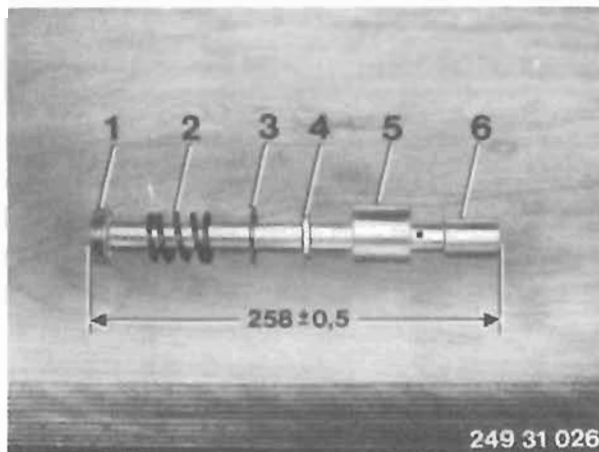

1. Piston with guide ring
2. Coil spring
3. Perforated disc
4. Valve disc
5. Valve housing
6. Damper tube

Adjustment dimension

258 ± 0.5 Nm

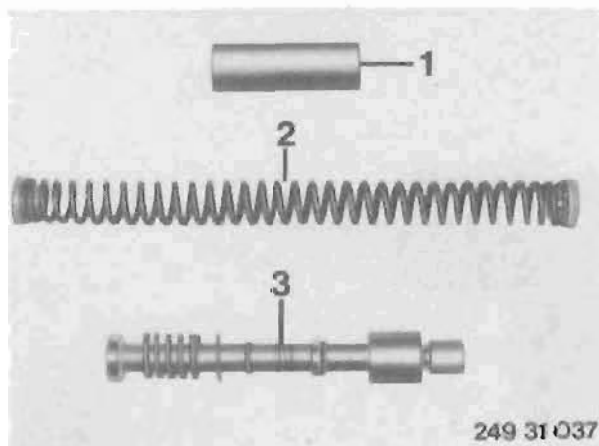

Telescopic fork  and 

Damper with O-ring, coil spring (soft) and valve with assembled O-ring

1. Spacer tube
2. Coil spring
3. Damper

1. Guide ring with notches (arrows), fitted at base
2. Piston
3. Coil spring
4. Perforated disc
5. O-ring
6. Coil spring (soft)
7. Valve with assembled O-ring (5), fitted at base
8. Valve housing
9. Damper tube

Adjusting dimension $x = 258 \pm 0.5$ mm

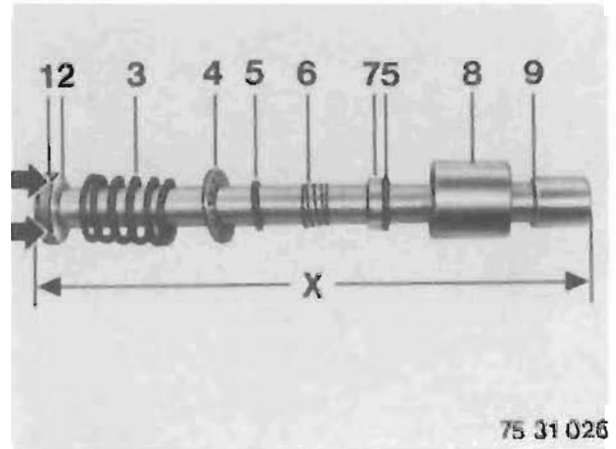

Telescopic fork with two-piece spring

1. Spacer tube
2. Coil spring
3. Damper

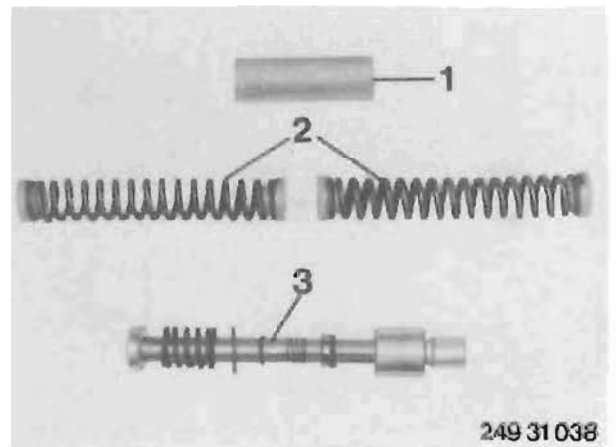

1. Guide ring with notches (arrows), fitted at base
2. Piston
3. Coil spring
4. Perforated disc
5. O-ring
6. Coil spring (soft)
7. Valve with assembled O-ring (5), fitted at base
8. Valve housing
9. Damper tube

Adjustment dimension $x = 260.5 \pm 0.3$ mm

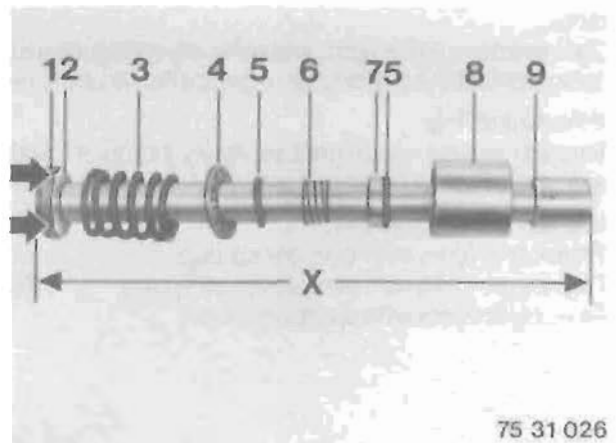

Sports telescopic fork Standard on K 75 s Special equipment option on K 75, c, K 100 RS

1. Spacer tubes
2. Coil springs
3. Damper, left
4. Damper, right

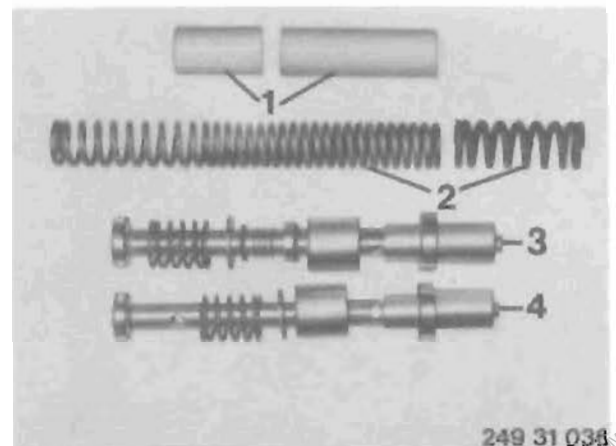

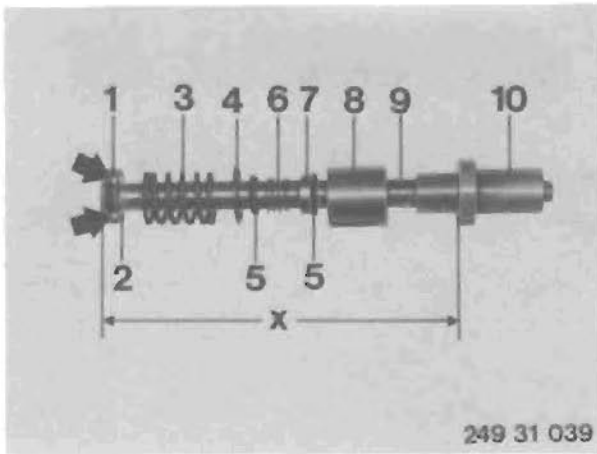

Left-hand damper

1. Guide ring with notches (arrows), fitted at base
2. Piston
3. Coil spring
4. Perforated disc
5. O-ring
6. Coil spring (soft)
7. Valve with assembled O-ring (5), fitted at base
8. Valve housing
9. Damper tube
10. Spacer

Adjustment dimension $x = 208 \pm 0.3 \text{ mm}$

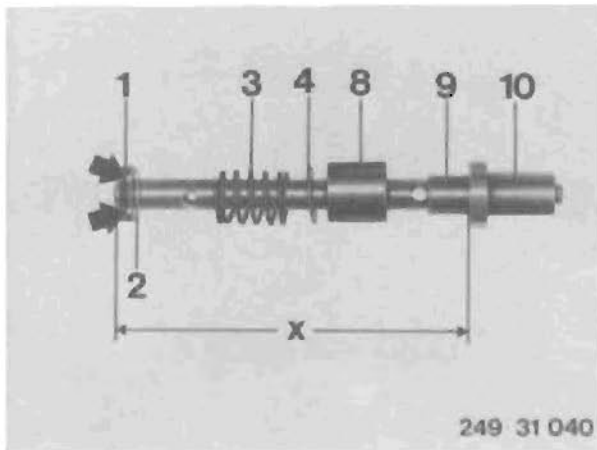

Right-hand damper

1. Guide ring with notches (arrows), fitted at base
2. Piston
3. Coil spring
4. Perforated disc
8. Valve housing
9. Damper tube
10. Spacer

Adjustment dimension $x = 208 \pm 0.3 \text{ mm}$

Note:

Clean parts in white spirit and blow dry with compressed air. The piston is secured to the damper tube with Loctite. To remove, heat the piston over a gentle flame until the Loctite begins to burn. Unscrew the piston out of the damper tube.

When installing:

Thread must be free of grease. Apply 1 drop of Loctite 638 to the thread and screw in the piston to the dimension specified. Harden in hot air or leave to dry for 24 hours at room temperature.

Adjustment dimensions:

Telescopic forks with long coil spring:	$258 \pm 0.5 \text{ mm}$
Telescopic forks with two-piece coil spring:	$260.5 \pm 0.3 \text{ mm}$
Telescopic forks with sports settings:	$208 \pm 0.3 \text{ mm}$

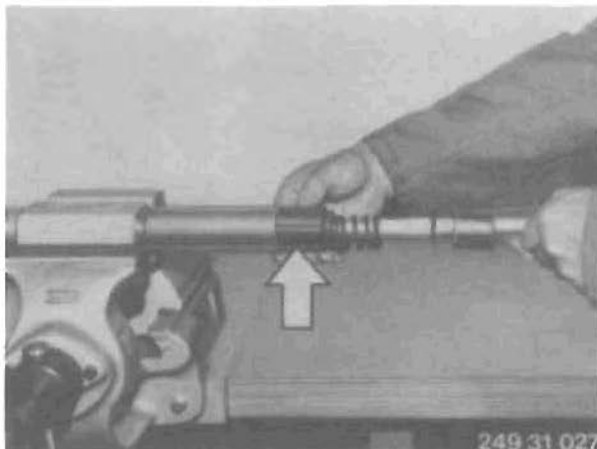

To install the damper in the fixed tube, use the mounting bushing, BMW 31 4 730 (arrow), to press together the guide ring.

When installing:

Shim the gap (arrow) between circlip (1) and valve housing (2) with shims until play has been eliminated.

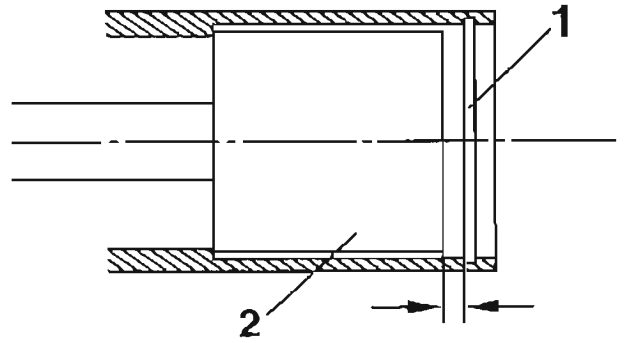

75 31 033

Carefully lever out the seal ring in the sliding tube with a screwdriver.

Drive in new sealing ring with BMW arbor 31 4 660 (arrow) and handle 00 5 500 until flush with the upper edge of the sliding tube.



249 31 028



Fluidbloc – removing and installing

Completely remove the telescopic fork (see page 31–11.0).

Pull off the bearing outer race at the top (see page 31–22.0).

Remove the tapered screws on left and right and take Fluidbloc out of the steering head tube.

Mark the Fluidbloc at its widest diameter; $x = 7$ mm.

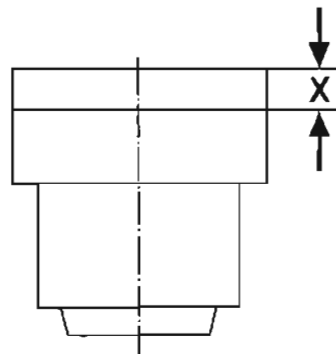

75 31 041

Fill Fluidbloc chambers (1) with silicone grease and insert in steering head tube (2) until the mark appears in the threaded holes. Insert tapered screws (3). Pull in bearing outer race (4) at top. Adjust the steering head bearing.

Note:

Use only **Grade 300 silicone grease**, as other lubricants will have an uncontrolled effect on the frictional value.

Tightening torque:

Tapered screws

9 ± 1 Nm

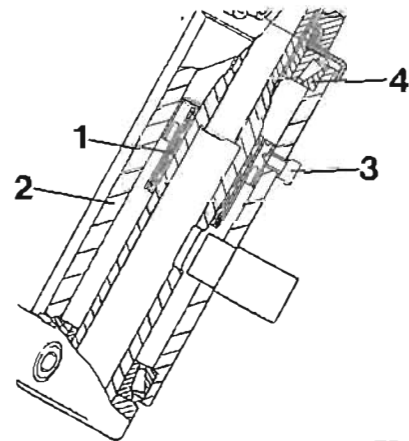

75 31 044

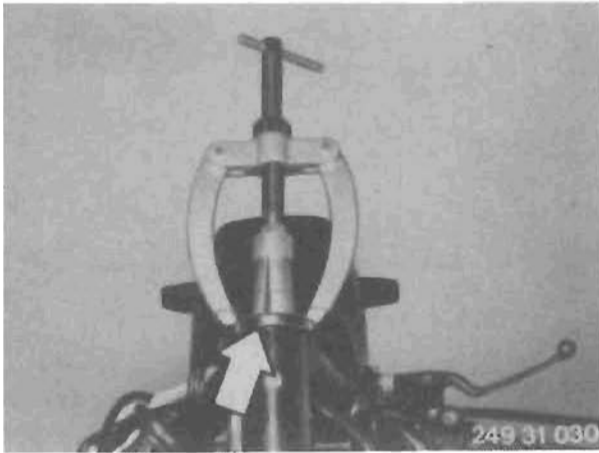

Taper roller bearing in steering head – removing and installing

Remove the complete telescopic fork (see page 31–11.0).

Pull out bearing outer race at top with Kukko puller, BMW 00 5 560, in conjunction with BMW support ring 31 4 800 (arrow).

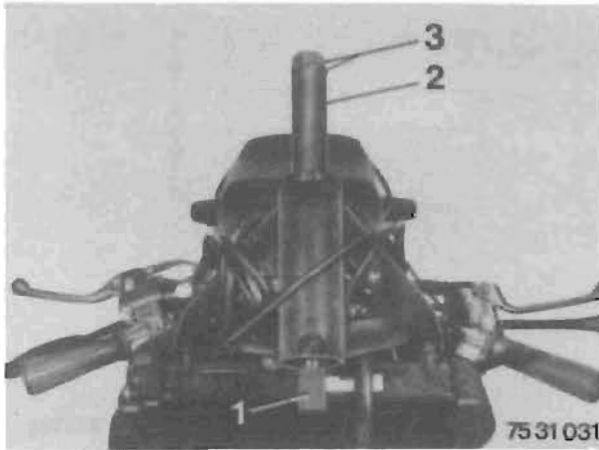

Pull in bearing outer race at top with spindle of frame alignment gauge (1) and spacer (2), BMW 31 4 820, together with ship and hex nut (3) as far as stop.

Repeat the process for the lower bearing outer race.

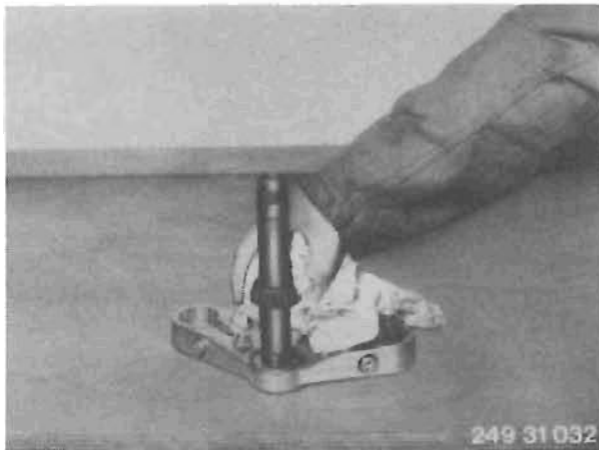

To remove the lower taper roller bearing, heat up the lower fork bridge to app. 120-130°C. Knock or press out the steering head tube downwards. Insert steering head tube again immediately.

Note:

Mark the installed position of the steering head tube on the fork bridge. Slot is for steering lock.

Heat up taper roller bearing to 80°C before installing, install ring (arrow) and taper roller bearing.

When installing:

There must be no play at the ring (arrow) between bearing and fork bridge.



(K 75 c from Frame No. 0 113 805)

Drive upper taper roller bearing evenly down from the bearing mounting with an arbor inserted through the holes in the adjusting ring.

When installing:

Heat up taper roller bearing to 80°C before installing, install ring and taper roller bearing.

There must be no play at the ring between bearing and fork bridge.

Telescopic fork – measuring

Remove telescopic fork (see page 31 – 11.0)

Strip down telescopic fork (see page 31 – 15.0)

Especially if the fork is damaged, carefully examine the lower fork bridge, fixed tubes and sliding tubes for any cracks.

Place each end of the dismantled fixed tubes in V-guides (illustration) and check runout with a dial gauge.

Maximum permitted runout 0.1 mm.

Warning:

Bent fixed tubes must not be straightened, or else fatigue fractures could occur.

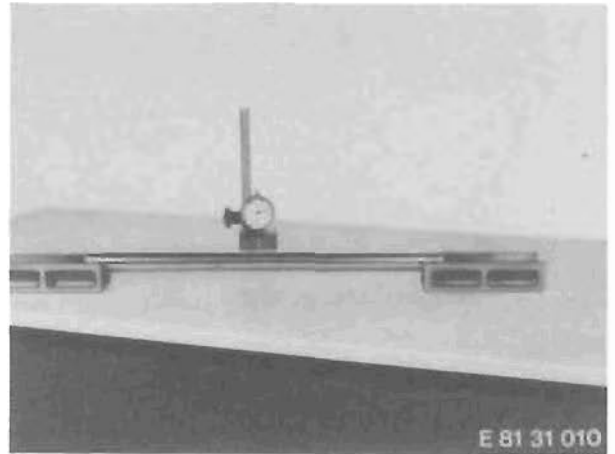

To check the lower fork bridge, push two new fixed tubes in the fork bridge.

Note:

Note control installed length of app. 180 mm from upper edge of fixed tube to upper edge of lower fork bridge.

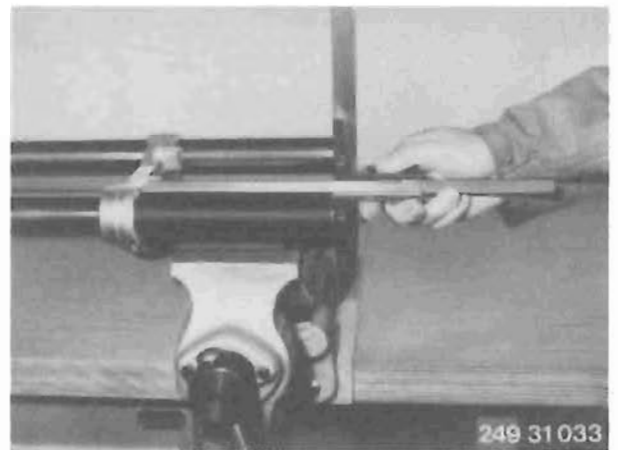

Place BMW straight edge 31 4 620 across the ends of the fixed tubes and look along them to determine any distortion.



Check that the fixed tubes are parallel with sliding calipers. Check that the steering tube is exactly flush with the fixed tubes and assemble the upper fork bridge.

Note:

Upper fork bridge must slide easily on to fixed tubes and steering head tube.



Telescopic forks – installing

Insert lower fork bridge in steering head tube.

●●●● (K 75 c from Frame No. 0 113 805)

Screw adjusting ring with taper roller bearing and locking tube on to steering head tube.

K 75 c up to Frame No. 0 113 804

Remove adhesive tape;

●●●● and K 75 c up to Frame No. 0 113 804

Fit taper roller bearing and screw round nut on to steering head tube.

Tightening torque:

Adjust the round nut and adjusting ring until there is no play.

Push fixed tubes in lower fork bridge.

Screw in clamping screw.

When installing:

Note adjustment dimension \times of app. 180 mm.

Tighten clamping screws finally after fitting the upper fork bridge.

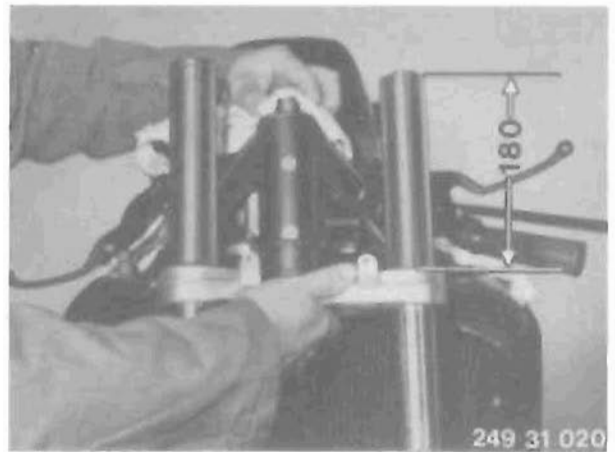
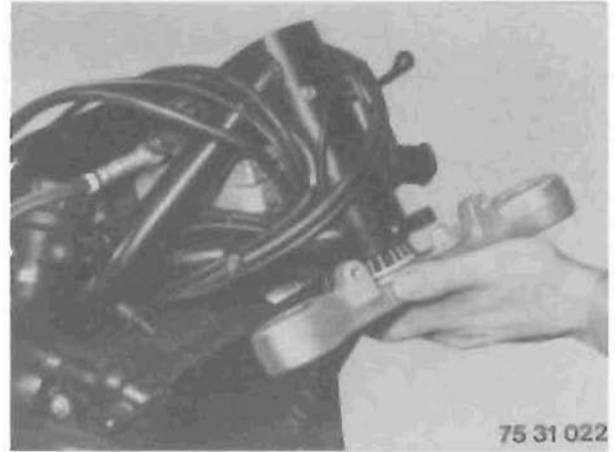

Set down handlebar to the front.

Push on upper fork bridge.

Screw in clamping screws (arrows).

When installing:

Fixed tubes must lie flush with upper fork bridge.

●●●● and K 75 c up to Frame No. 0 113 804

Screw in stop screw (1).

●●●● (K 75 c from Frame No. 0 113 805)

Screw on hex nut.

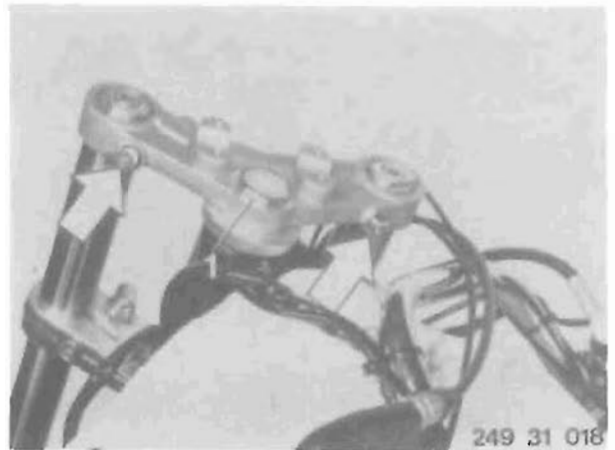

Renew grease in bushings if necessary. Push sliding tubes with bushings on fixed tubes. Tighten retaining screws for dampers slightly.



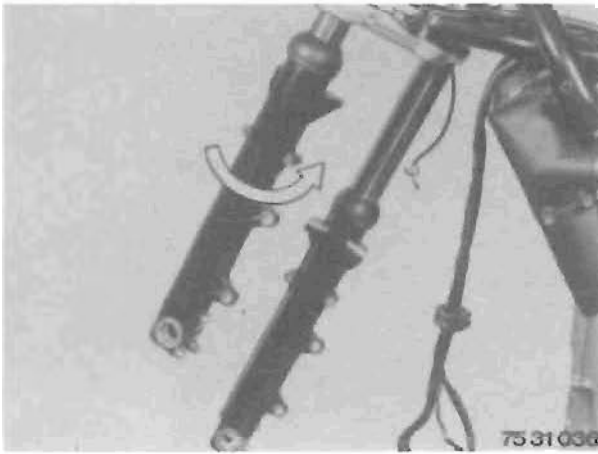

Push up sliding tubes separately until metallic contact is heard, and twist 2-3 times round the fixed tube. Tighten the damper retaining screws while compressed.

Note:

If tension is felt when twisted again, release the damper retaining screws and repeat the assembly process.

Tightening torque:

Damper retaining screws 20 ± 2 Nm

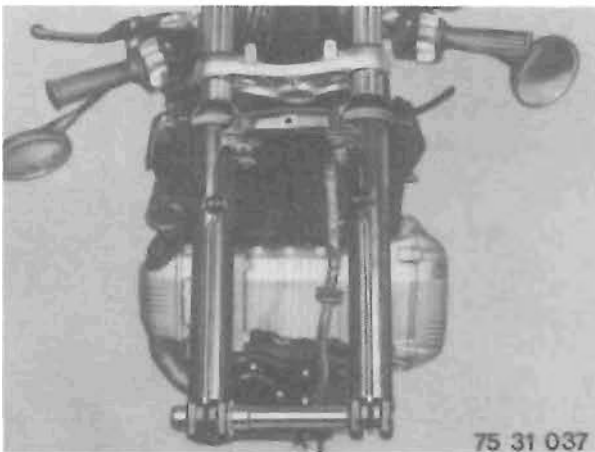

Models with fork stabiliser

Assemble the fork stabiliser and tighten the retaining screws **slightly**. Push in the quick-release axle and tighten the clamping screws on one side. Push up the sliding tubes until metallic contact is heard, then tighten the other retaining screws.

Note:

Tighten retaining screws for fork stabiliser in a crosswise pattern.

Tightening torque:

Clamping screws 14 ± 2 Nm

Retaining screws for fork stabiliser 21 ± 2 Nm

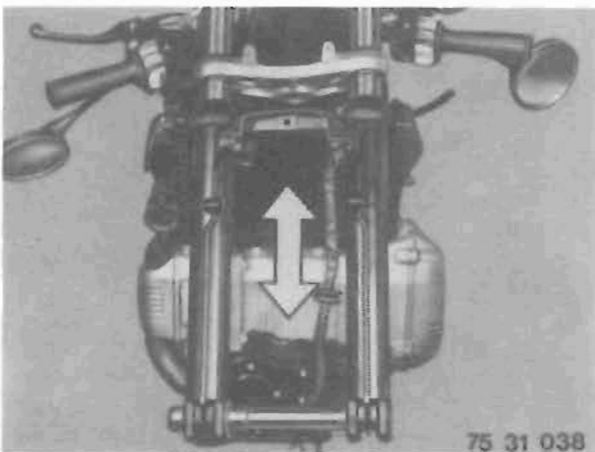

Quick-release axle must slide easily into the fork sliding tubes.

Note:

If resistance is encountered when pushing to and fro, dismantle the telescopic fork and measure.

Install the front wheel and front mudguard.

Secure brake calipers to sliding tubes. Screw in the oil drain plug. Insert the coil spring with spring bearing and spacer tube.

Note:

When adding oil, the front axle must be off-load. Only use approved oil grades (see Technical Data, page 31 – 03.0).

Install spring bearing with snap ring and attach cover.

Tightening torques:

Quick-release axle 33 ± 4 Nm

Brake caliper on sliding tube 32 ± 2 Nm

Oil drain plug 9 ± 1 Nm

Oil filler plug 15 ± 2 Nm

Steering head tube – installing

When installing:

Punch mark (arrow) must be located between the clamp halves when assembled.

Tighten retaining screws for clamps.

Tightening torque:

Retaining screw 22 ± 2 Nm

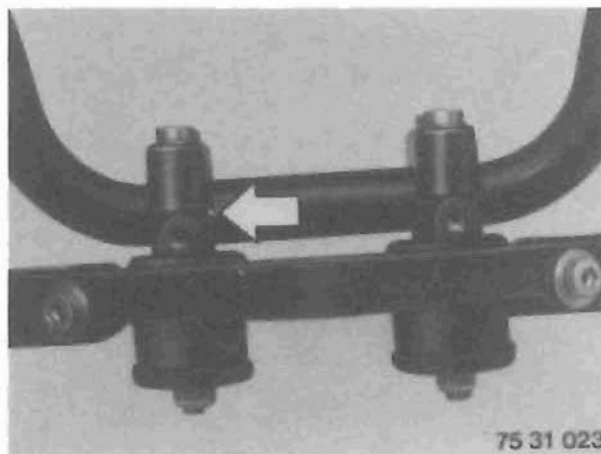

Adjust steering head bearing, remove tapered screws for Fluidbloc.

 (K 75 c from Frame No. 0 113 805)

Eliminate all play at adjustment ring, tighten locking tube and hex nut.

 and K 75 c up to Frame No. 0 113 804

Eliminate all play at round nut, tighten stop screw.

Tighten clamping screws at top and then at bottom.

Tightening torques:

Stop screw 74 ± 5 Nm

Locking tube and hex nut (5 mm deep) 45 ± 3 Nm

Locking tube and hex nut (7 mm deep) 65 ± 5 Nm

Clamping screws, top 21 ± 1 Nm

Clamping screw, bottom 43 ± 3 Nm

Note:

When off-load, the telescopic fork must fall evenly to the left or right from the centre position.

Ensure that the wire cables and electric cables are located properly.



Tighten tapered screws again.

Tightening torque:

Tapered screws 9 ± 1 Nm

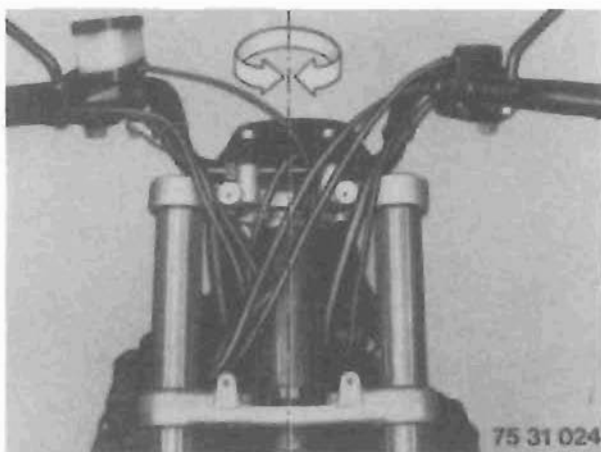

Push distributor pipe up through steering head tube.

When installing:

When installing, note the lug at the base of the distributor pipe and on the groove in the fork bridge.

 (K 75 c from Frame No. 0 113 805)

Fit clamp to distributor pipe with a suitable pipe (spring lugs point upwards).

 and K 75 c up to Frame No. 0 113 804

Secure distributor pipe with plastic nut (smooth side downwards).

Tightening torque:

Plastic nut 10 ± 1 Nm



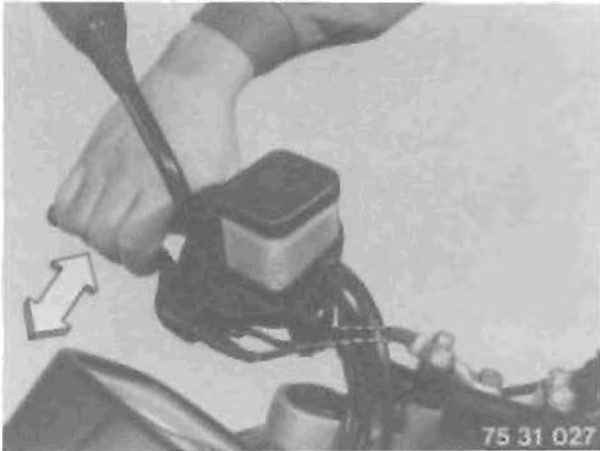

Secure brake line to the distributor pipe with hollow screw and new sealing rings.
Turn handlebar to left-hand lock, apply the handbrake and then release quickly, repeating the operation several times to bleed the circuit, until the pressure point can be felt.

Tightening torque:
Hollow screw

$7 \pm 1 \text{ Nm}$

Install the impact pad.
Install the fuel tank (see group 16).
Install headlights, instrument cluster and fairing sections.
Check the headlight beam setting.

Note:

Compress the motorcycle suspension and check the functioning of the telescopic fork. Renewed slight resistance in the telescopic fork, similar to when new, can never be avoided entirely when work is performed on it. A renewed running-in distance of not more than 1000 km must therefore be taken into account.

32

Steering

32 Steering

Specifications	Page	32-03.0
Tightening torques		32-03.0
Diagrams		32-05.0
Handlebar – removing and installing		32-07.0
Right-hand handlebar fittings – removing		32-07.0
Left-hand handlebar fittings – removing		32-08.0
Wire throttle cable – removing		32-11.0
Wire throttle cable – installing		32-12.0
Wire cable for increased starting speed – removing and installing		32-13.0
Increased starting speed – adjusting		32-15.0
Wire clutch cable – removing and installing		32-15.0
Clutch play – adjusting		32-16.0

Steering**Specifications**

Model	K 75	K 75 c	K 75 s	K 100	K 100 RS	K 100 RT	K 100 LT
Steering lock to either side	40°		35°	40°	35°		
Handlebar width	mm	665	610	730	610	775	
Steering head tube Ø	mm	22					

Steering**Tightening torques**

Connection	Nm
Steering block, clamp halves	22 ± 2
Steering block to upper fork bridge	16 ± 2
Mirror to housing	15 ± 3

Left handlebar grip

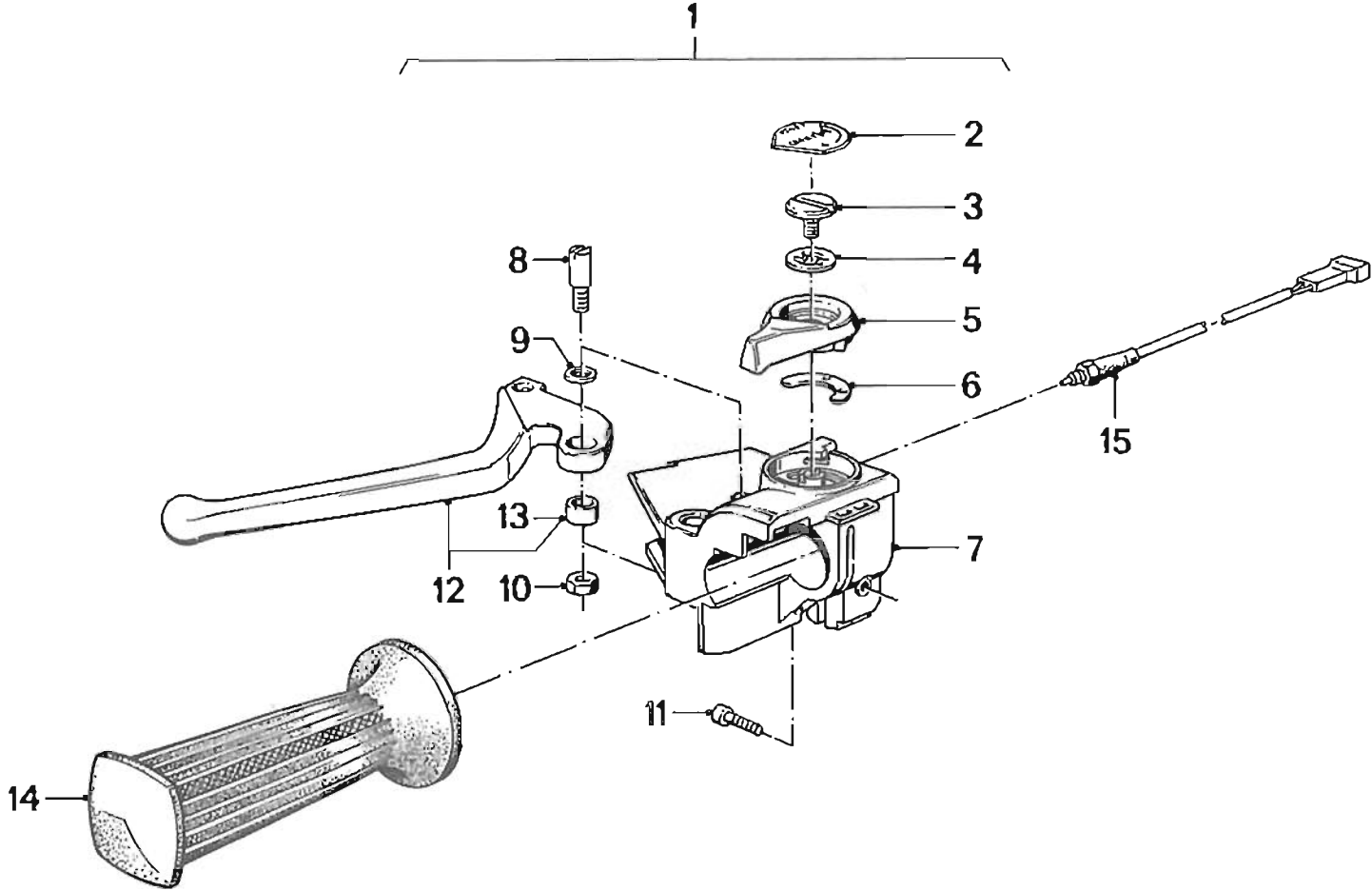

- 2 Cap
- 3 Slotted Screw
- 4 Washer
- 5 Lever
- 6 Detent plate
- 7 Housing
- 8 Headless screw

- 9 Spring washer
- 10 Hex nut
- 11 Machine screw
- 12 Hand lever
- 13 Bushing
- 14 Grip
- 15 Switch with cable

Right handlebar grip

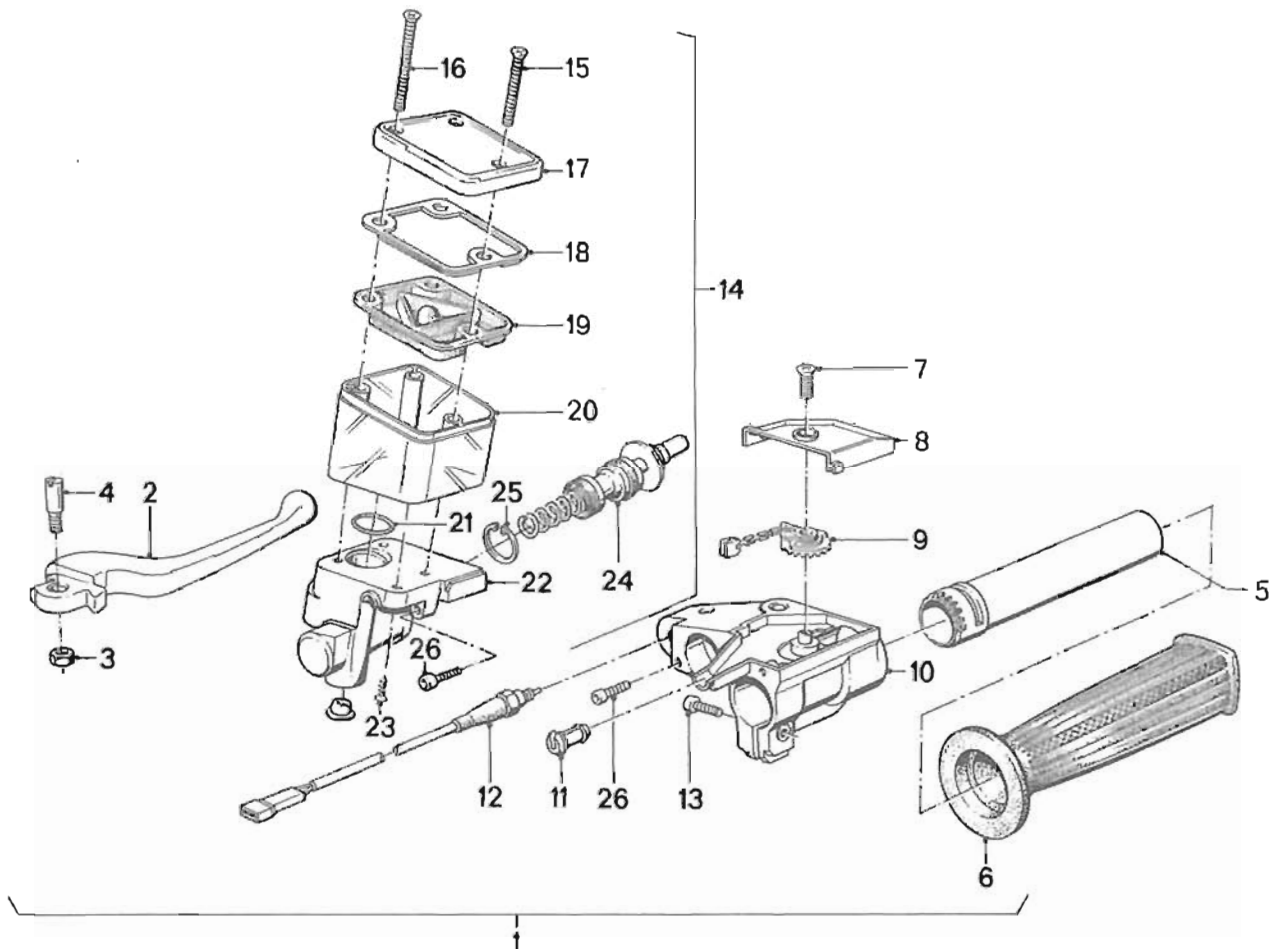

Throttle twistgrip

- 5 Handlebar tube
- 6 Grip
- 7 Countersunk screw
- 8 Cover
- 9 Cam
- 10 Housing
- 11 Support block
- 12 Switch with cable
- 13 Machine screw

Handlebar – removing and installing

Remove fuel tank (see Group 16).

Disconnect plug connection for handbrake light switch and clutch switch under fuel tank.

Lever off marked disc for ignition lock with a small screwdriver.

Push retaining hooks on either side for ignition lock inwards with a small screwdriver and push the ignition lock down to remove.

Release the retaining screws (arrows) and take off the impact pad.



Right handlebar fitting – removing

Remove the cover from the throttle operating mechanism. Using actuating cam (1), pull the chain through until the cable can be disconnected at the end of the chain (arrow). Pull off the twistgrip.

When installing:

Before assembly, grease the actuating cam, twistgrip teeth and handlebar end.

When assembling, make sure that the mark on the tooth of the twistgrip is aligned with the mark on the actuating cam.



Remove retaining screw (arrow) and take off the switch.



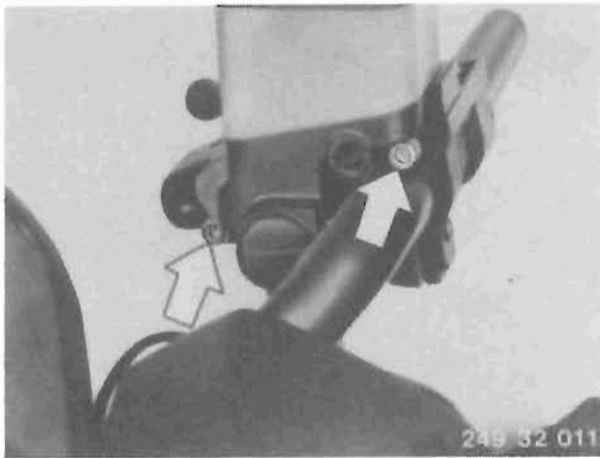

Remove the retaining screws on the brake fluid reservoir (arrows).

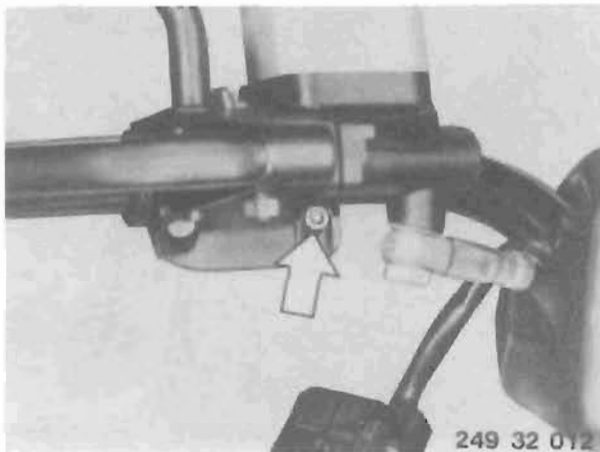

Slacken off the clamping screw on the fitting housing (arrow) and pull the fitting off the handlebar. Allow the brake fluid reservoir to hang down.

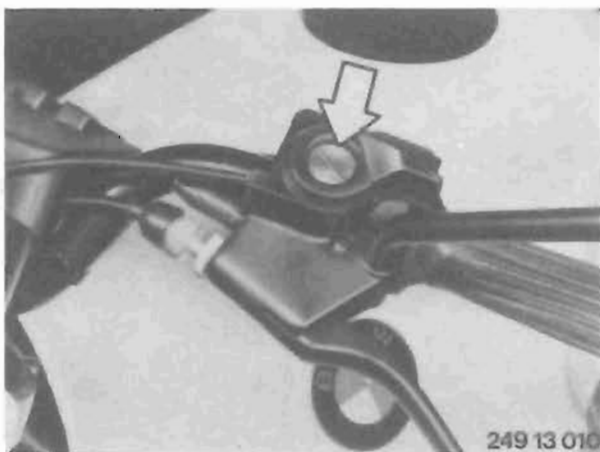

Left handlebar fitting – removing

Lever off plastic cap on increased idle speed actuator lever with a screwdriver and remove the slotted screw (arrow).

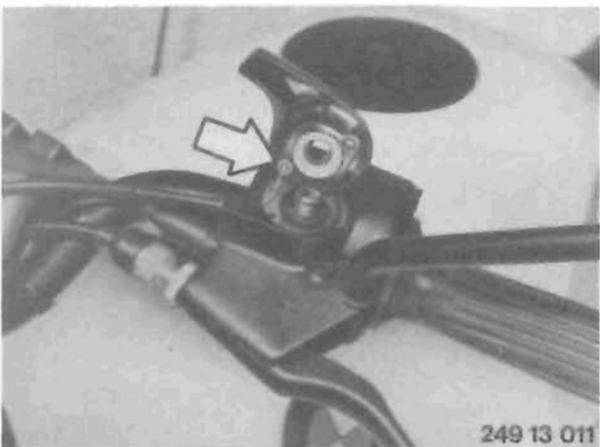

Lift off the actuator lever and disconnect the cable (arrow).

Pull back the wire sleeve and feed the cable out through the slot in the side of the housing.

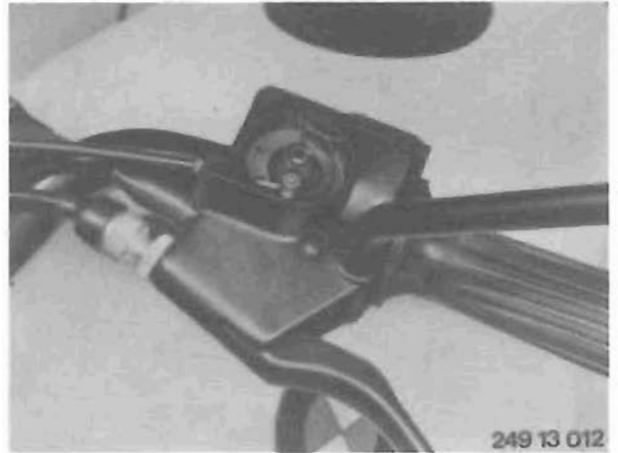

Disconnect the clutch cable at the withdrawal lever (arrow).

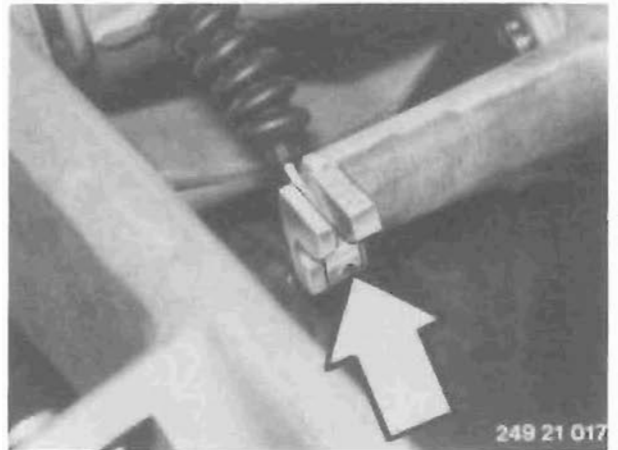

Pull the clutch lever.
Push nipple mounting (1) down out of the clutch lever with an arbor.

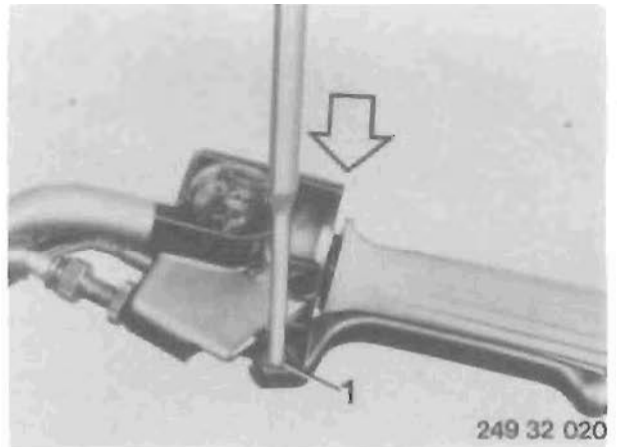

Push back the nipple mounting in the direction of the arrow until it is above the clutch cable and disconnect. Pull clutch cable out of fitting.

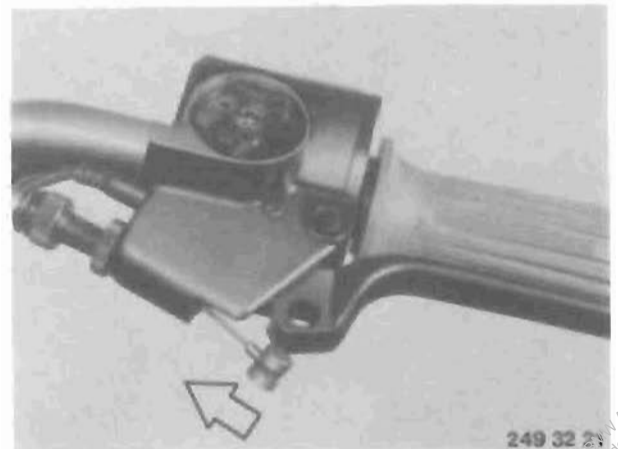

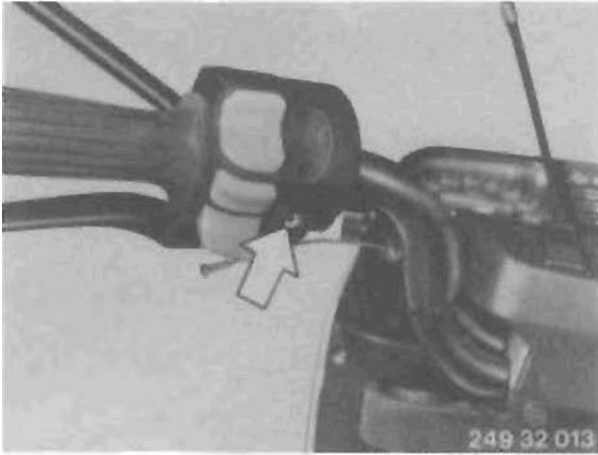

Remove switch at left on fitting (arrow).

Cut open rubber handgrip with knife and take off.

When installing:

Secure rubber handgrip to handlebar with Loctite 496.

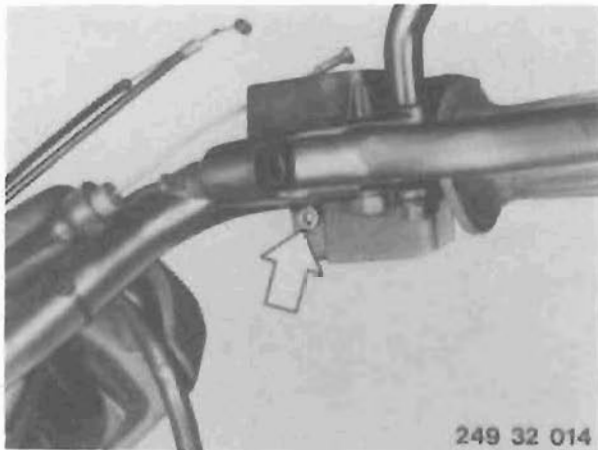

Slacken off clamp screw (arrow) on fitting housing and pull fitting off handlebar.

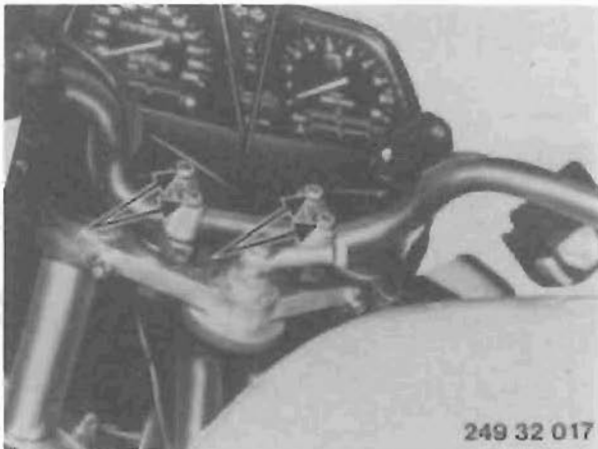

Remove handlebar mounting clamp screw and take off handlebar.

Install following the same procedure but in the reverse order.

When installing:

Punch mark (arrow) must be located between the clamp halves when assembled.

Tighten retaining screws for clamps.

Tightening torque:

Retaining screw

$22 \pm 2 \text{ Nm}$

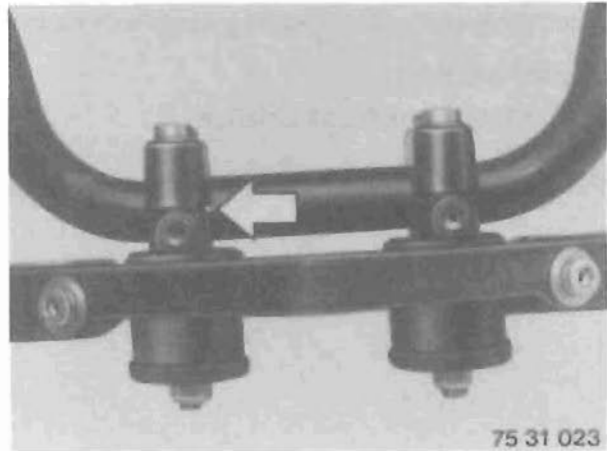

Throttle cable – removing



Remove fuel tank (see Group 16).

Remove impact pad.



K 100 RS, RT, LT: remove knee pads on left and right and remove lower left fairing (see Group 46). Remove fuel tank (see Group 16). Remove impact pad.

Turn cam disc inwards in the direction of the arrow.

Disconnect the cable.

Lift the cable out of the reaction bearing.

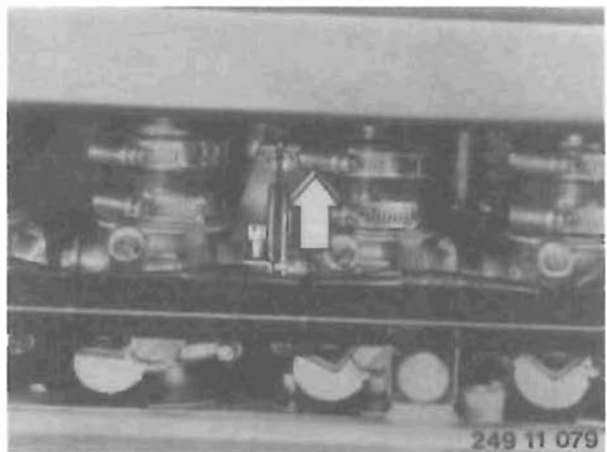

Remove the cover from the throttle operating mechanism.

Using actuating cam (1), pull the chain through until the cable can be disconnected at the end of the chain (arrow).

Pull the chain out of the handlebar fitting.



Open cable connector at front right corner of frame triangle.

 and K 100

Pull cable up through frame triangle.

K 100 RS, RT, LT:

Pull cable down between the upper edge of the radiator and the frame, and remove.

Throttle cable – Installing

 and K 100:

Pull cable from top to bottom through frame triangle.

K 100 RS, RT, LT:

Push cable from below between the upper edge of the radiator and the frame, and pull up. Install the cable above the connecting hose (top of air cleaner housing to air collector).

Note:

Do not kink the cable, as kinks will be subject to abrasion and the cable could fray as a result.

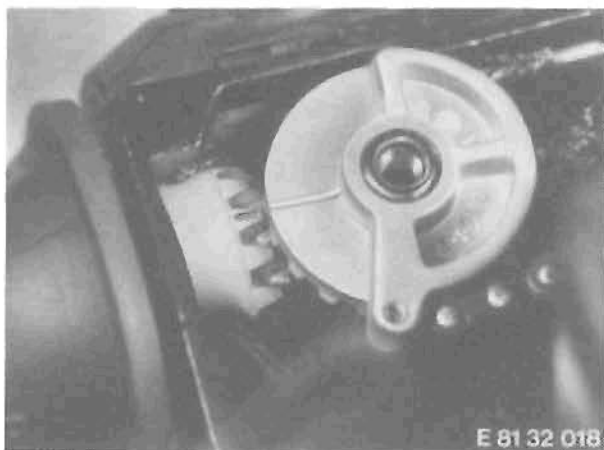

Connect cable to end of chain.

When assembling, ensure that the mark on the twistgrip tooth corresponds to the mark on the actuating cam. Fit the cover and tighten the retaining screw.

Note:

Before assembling, grease the actuating cam, twistgrip teeth and handlebar end.

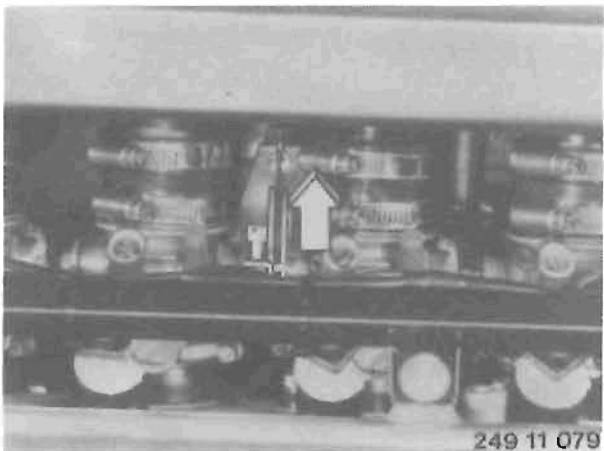

Turn cam disc inwards in the direction of the arrow and connect the cable.

Install the cable in the reaction bearing. (Adjust the reaction bearing if necessary by releasing the retaining screw).

Install cable connector in front right corner of frame triangle.

Set throttle cable play to 1 mm at adjuster on right handlebar fitting. Push rubber sleeve over adjuster.

Note:

The throttle butterfly switch must be heard to click when the twistgrip is turned slightly.

Install the impact pad.

Install the fuel tank.



K 100 RS, RT, LT: install the lower left fairing section and the knee pads on left and right.

Increased starting speed cable – removing and installing



Remove fuel tank (see Group 16).

Remove impact pad.



K 100 RS, RT, LT: remove knee pads on left and right (see Group 46).

Remove fuel tank (see Group 16).

Remove impact pad.

Disconnect wire cable on handlebar:

Lever off plastic cap on actuator lever with a screwdriver and remove the slotted screw (arrow).

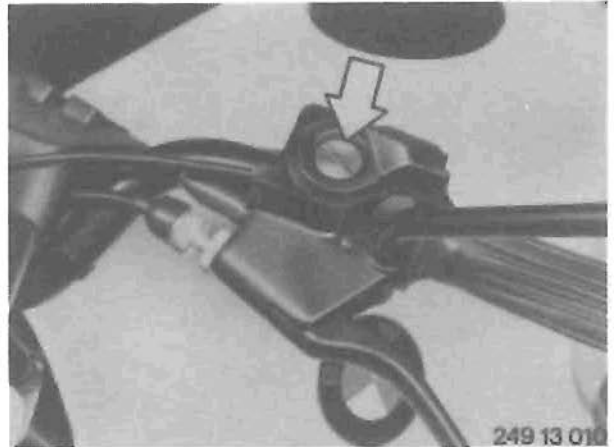

Lift off the actuator lever and lift out the cable (arrow).

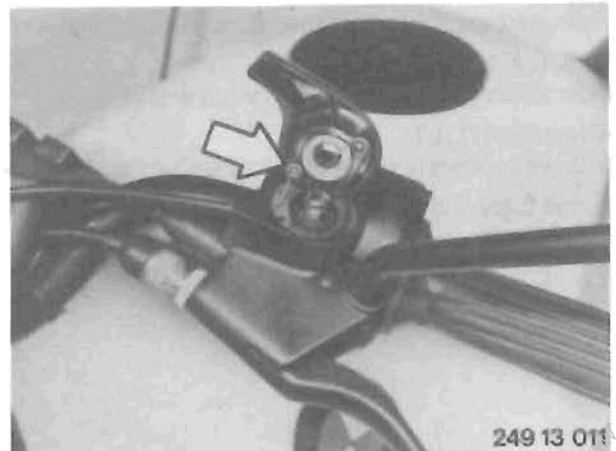

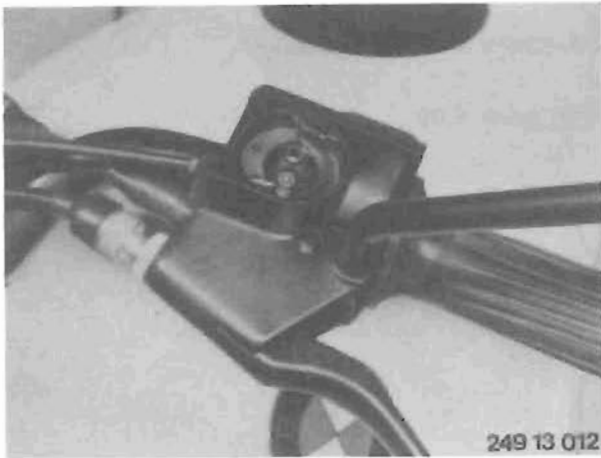

Pull back the sleeve on wire cable and feed the cable out through the slot in the side of the housing.

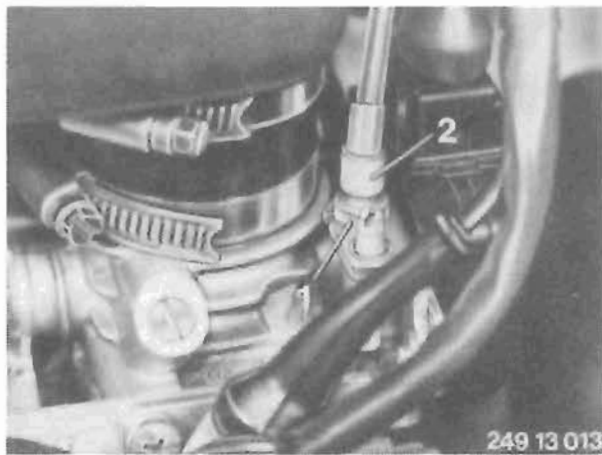

Disconnect wire cable in throttle butterfly system:
Slacken off locking nut (1) for adjusting screw (2) and unscrew adjusting screw completely (remove).



Push cable forward past bracket (arrow) on lever and disconnect.

When installing:
Connect cable up to lever with the aid of pointed pliers.

Release the cable connector at the front right corner of the frame triangle.

K 75, c, s, K 100:

Pull cable up through frame triangle and remove.

K 100 RS, RT, LT:

Pull cable down between radiator upper edge and frame, and remove.

Install following the same procedure but in the reverse order.

Increased starting speed – adjusting

Increased starting speed is adjusted at adjuster screw (1)
(slacken locking nut (2) first).

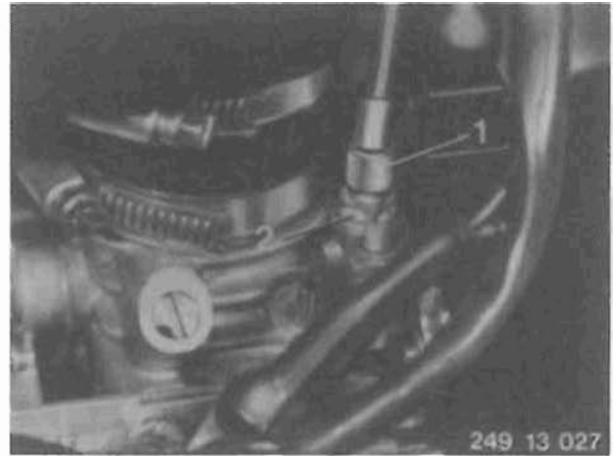

Push in the choke on handlebar by the first stage and turn
adjuster screw (1) until the idle adjuster screw rises
through dimension "a". The second stage must then
produce dimension "b".



Dimension "a" 1.5 mm
Dimension "b" 3.5 mm



Dimension "a" 1.0 mm
Dimension "b" 2.5 mm

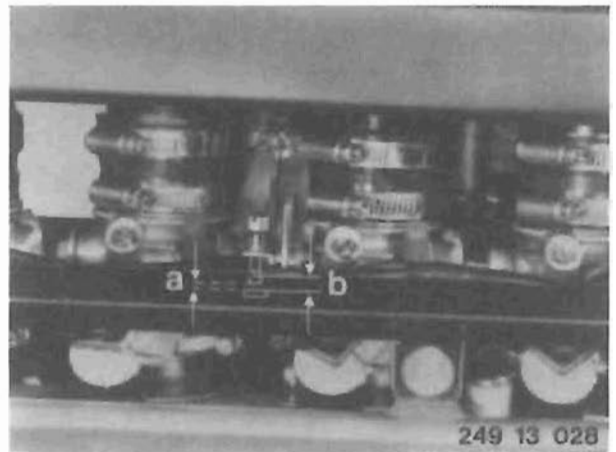

Clutch cable – removing and installing



Remove fuel tank (see Group 16).
Remove impact pad.



K 100 RS, RT, LT: remove knee pads on left and right (see Group 46).
Remove fuel tank (see Group 16).
Remove impact pad.

Disconnect clutch cable (arrow) and pull out of gear
housing.
Release cable connector beneath the battery trim
mounting.

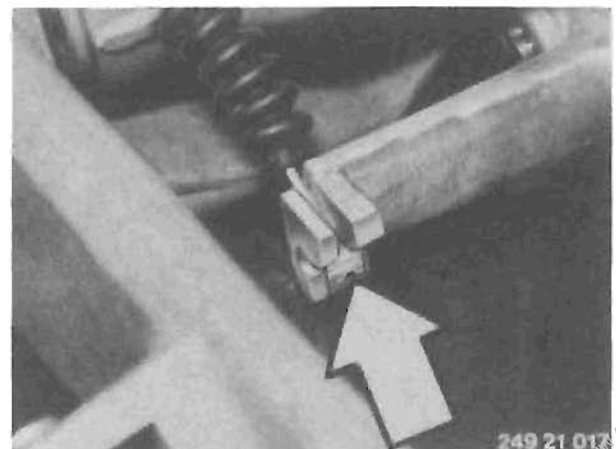

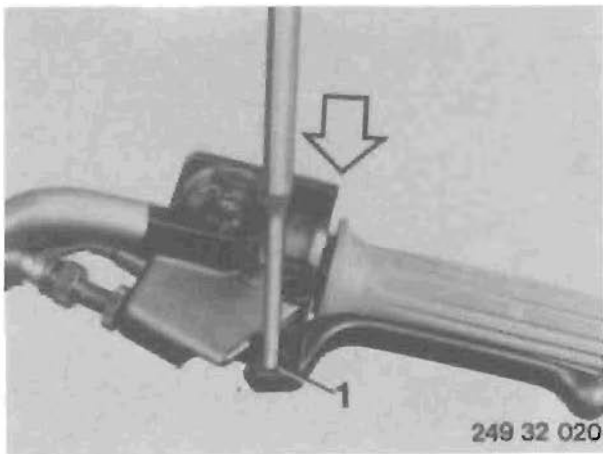

Pull clutch lever.
Push nipple mounting out of clutch lever with drift.

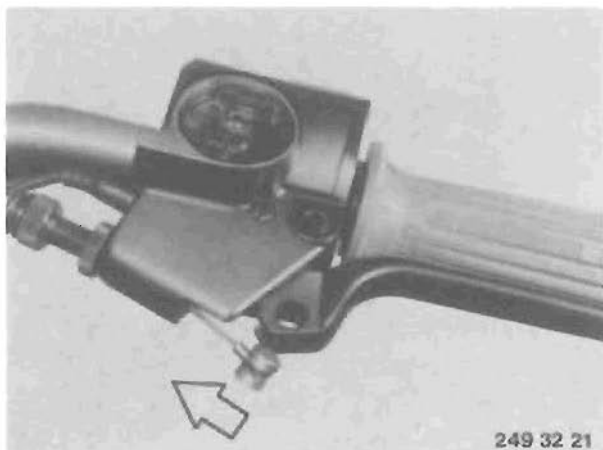

Push back nipple mounting in the direction of arrow until it is above the clutch cable, and disconnect.
Pull clutch cable out of fitting.

Release the cable connector at front right corner of frame triangle.

K 75, c, s, K 100:

Pull cable up through frame triangle to remove.

K 100 RS, RT, LT:

Pull cable down between upper radiator edge and frame to remove.

Install following the same procedure but in the reverse order.

Do not connect the clutch cable to the withdrawal lever yet.

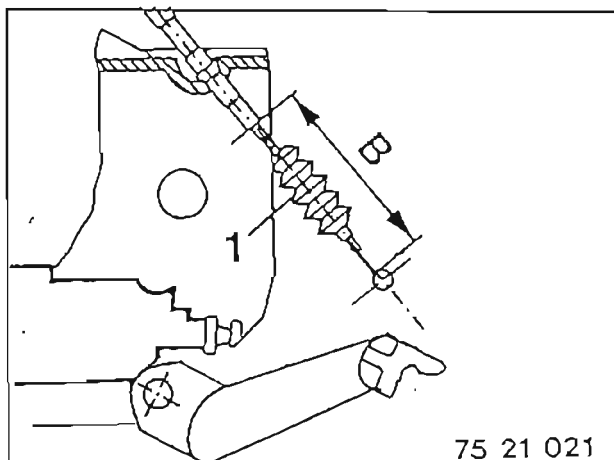

Clutch play – adjusting

Push back rubber grommet (1) slightly and set dimension "B" to 75 ± 1 mm at adjuster on clutch lever with BMW adjuster gauge 21 3 500.

Slacken off knurled nut (1) of adjuster screw on clutch lever and turn adjuster screw (2) to obtain dimension "B". Reconnect clutch cable to withdrawal lever.

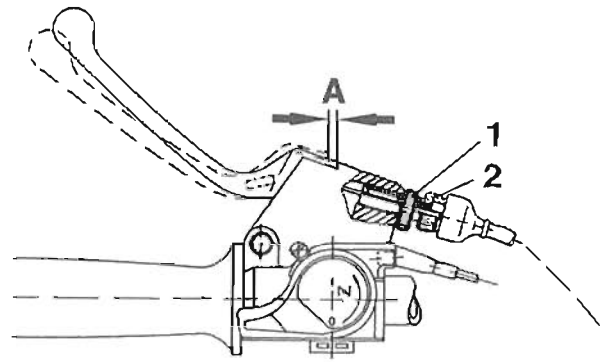

75 21 020

Slacken off locking nut (1).
Slacken off adjuster screw (arrow) through one to two revolutions, slowly screw in until pressure point is felt, then secure with lock nut (1).

After the basic adjustment procedure, adjust play at clutch lever to dimension "A" with adjuster screw and secure with locking nut.

Warning:

Only adjust the screw on the withdrawal arm to compensate for wear.

 "A" = 2 + 0.5 mm

 "A" = 4 + 0.5 mm

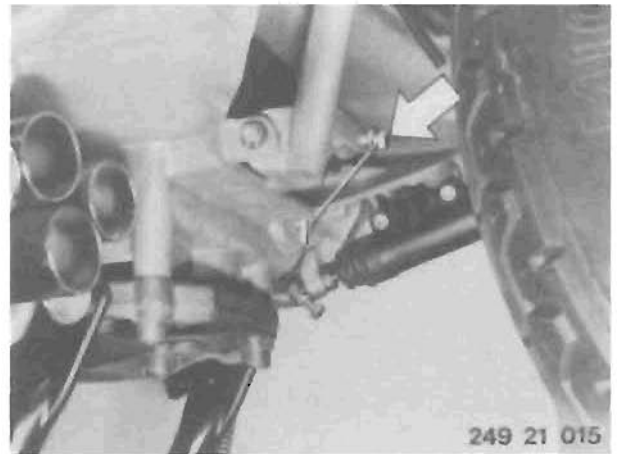

249 21 015

33

Rear wheel drive

33 Rear wheel drive

Specifications	Page	33-03.0
Tightening torques		33-04.0
Diagrams		33-05.0
Rear wheel drive – removing		33-09.0
Rear wheel drive – stripping down		33-11.0
Drive pinion removing		33-11.0
Housing cover – removing		33-13.0
Shaft sealing ring in housing cover – removing and installing		33-13.0
Bearing shell for taper roller bearing – removing		33-14.0
Needle roller bearing for input bevel pinion – removing		33-14.0
Crown wheel bearing – removing		33-14.0
Rear wheel drive – measuring and assembling		33-15.0
Input bevel pinion – shimming		33-15.0
Needle roller bearing for input bevel pinion – installing		33-16.0
Input bevel pinion – installing		33-16.0
Shaft sealing ring in threaded ring – removing and installing		33-17.0
Crown wheel – shimming (tooth backlash, wear pattern)		33-18.0
Taper roller bearing preload – calculating		33-21.0
Housing cover – installing		33-21.0
Rear swinging arm – removing		33-22.0
Drive shaft – removing		33-23.0
Universal joint – checking for wear		33-23.0
Drive shaft snap ring – removing and installing		33-23.0
Rear swinging arm taper roller bearings – removing and installing		33-23.0
Sealing sleeve between swinging arm and gearbox – removing and installing		33-24.0
Rear swinging arm – installing		33-25.0
Drive shaft – installing		33-25.0
Final drive – installing		33-26.0

Rear wheel drive

Specifications

Model		K 75	K 75 c	K 75 s	K 100	K 100 RS	K 100 RT	K 100 LT	
Rear wheel drive									
Tooth type		Klingelnberg (Palloid) spiral bevel							
Number of teeth		10 : 32			11 : 32	11 : 31	11 : 32		
Ratio		1 : 3.2			1 : 2.91	1 : 2.81	1 : 2.91		
Special version	No. of teeth	11 : 32		11 : 34	11 : 33	11 : 32	11 : 33		
	Ratio	1 : 3.36		1 : 3.09	1 : 3.0	1 : 2.91	1 : 3.0		
Tooth backlash	mm	0.07 ... 0.16							
Shims available in units of 5/100 mm									
Crown wheel	mm	1.95... 2.80							
Pinion	mm	1.50 ... 2.10							
Taper roller bearing preload	mm	0.05 ... 0.1 $\hat{=}$ 600 ... 1600 N preload							
Available shims	mm	0.18 / 0.28 / 0.38 / 0.50 / 0.63 / 0.75 / 0.88							
Oil grade	above 5°C below 5°C all year	Brand-name hypoid gear oil, SAE 90 Brand-name hypoid gear oil, SAE 80 Brand-name hypoid gear oil, SAE 80 W 90					} API-class GL 5		
Filling capacity	l	0.26							
Drive shaft:									
Layout		Enclosed drive shaft in swinging-arm tube with integrated torsional vibration damper and universal joint with needle roller bearing, with snap ring at gearbox end.							
Rear suspension		Single swinging arm with 3-position spring strut and double-acting hydraulic shock absorber							
Spring travel	mm	110							
Spring length, off-load	mm	274 \pm 3			265 ⁺⁴				
Wire diameter	mm	9			9.86				

Rear wheel drive

Tightening torques

Connection	Nm
Threaded ring in rear wheel drive	118 ± 12
Nut on input bevel pinion	200 ± 20
Retaining screws on gear housing cover	21 ± 2
Brake disc on final drive	21 ± 2
Swinging arm fixed bearing to gearbox	9 ± 1
Swinging arm moving bearing journals	7.5 ± 0.5
Locking nut to swinging arm moving bearings	41 ± 3
Rear wheel drive to swinging arm	40 ± 3
Spring strut to frame/rear wheel drive	51 ± 6
Brake caliper to rear wheel drive	32 ± 2
Wheel studs (rear)	105 ± 4
Oil drain plug, rear wheel drive housing	25 ± 3
Oil filler plug, rear wheel drive housing	20 ± 2
Inductive transmitter to rear wheel drive	2.5 ± 0.5

Bevel pinion bearings

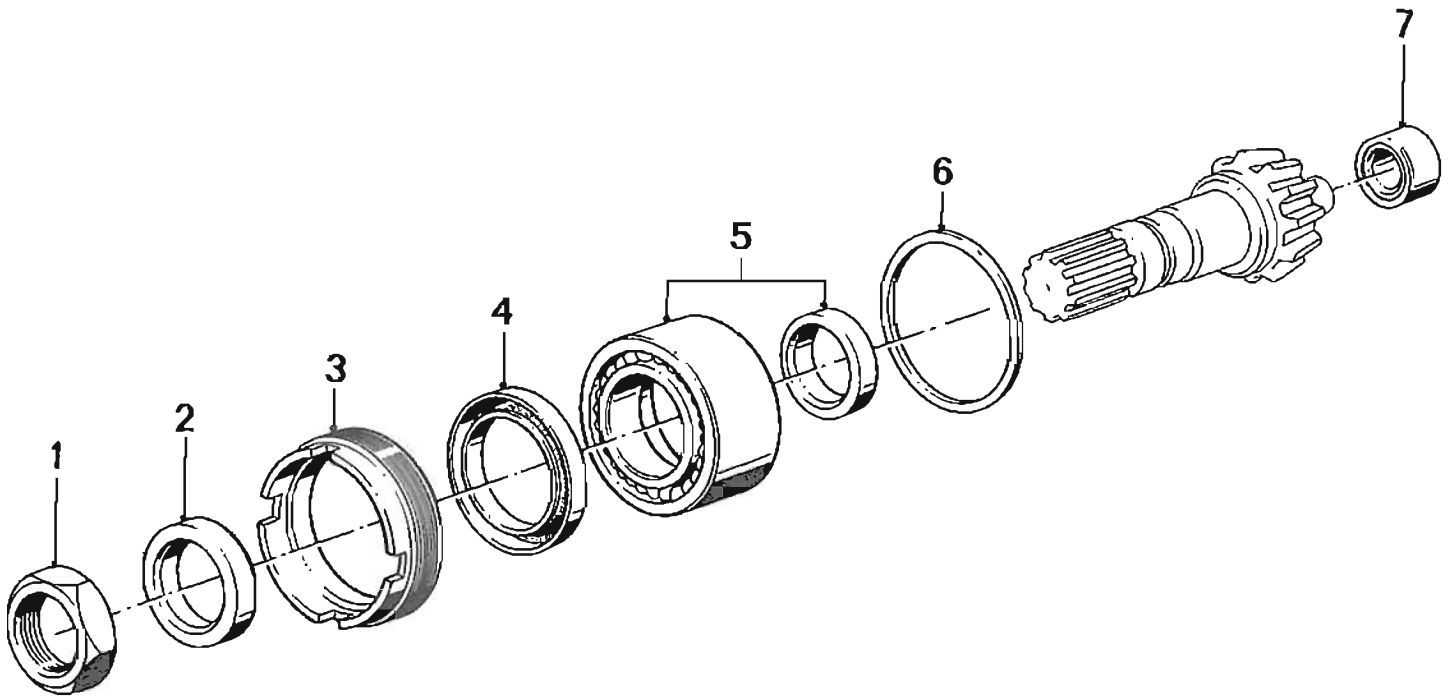

- 1 Nut
- 2 Thrust ring
- 3 Threaded ring
- 4 Shaft sealing ring
- 5 Ball thrust bearing
- 6 Spacer
- 7 Needle roller bearing

Crown wheel bearings

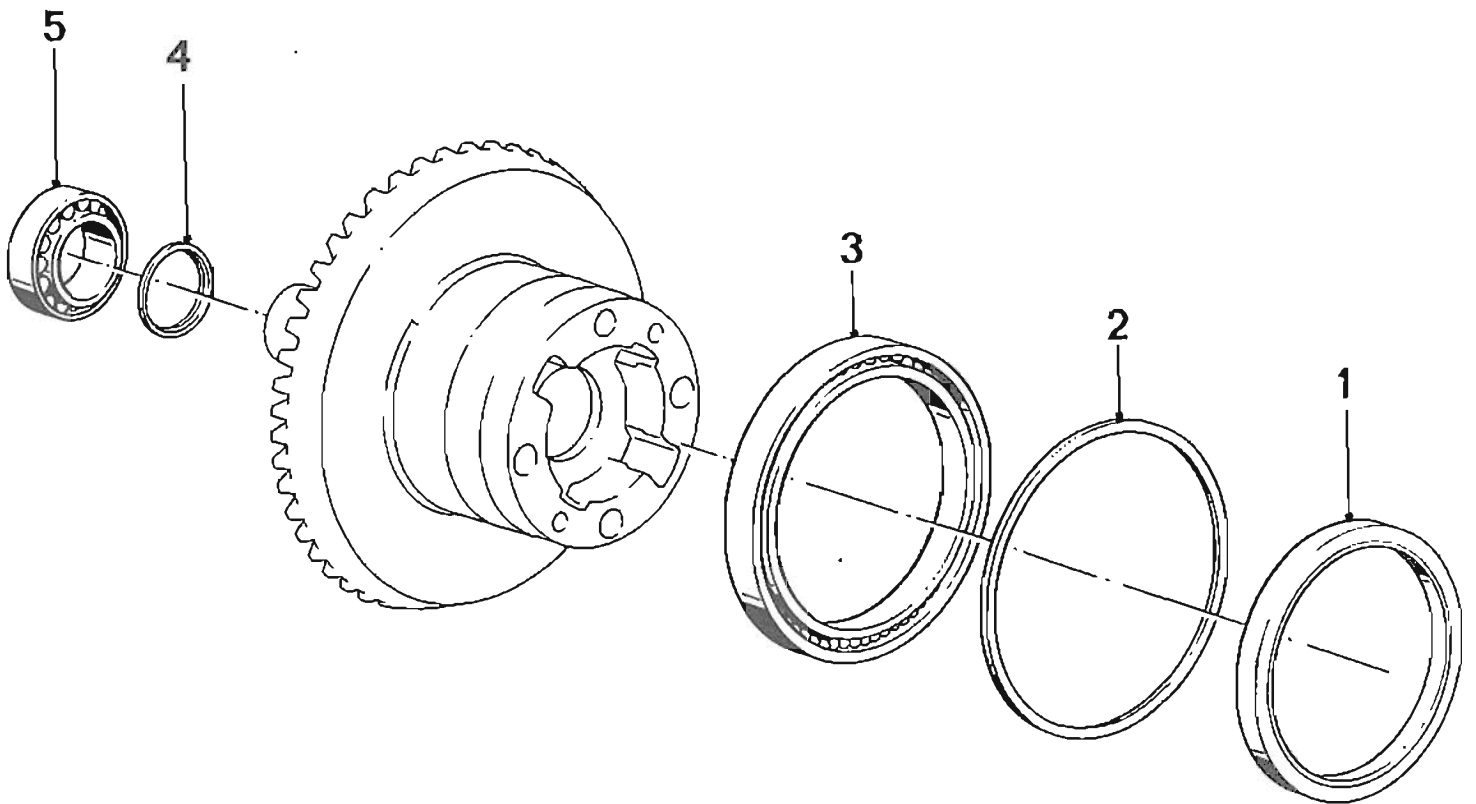

- 1 Shaft sealing ring
- 2 Spacer
- 3 Deep groove ball bearing
- 4 Spacer
- 5 Taper roller bearing

Spring strut and swinging arm with drive shaft

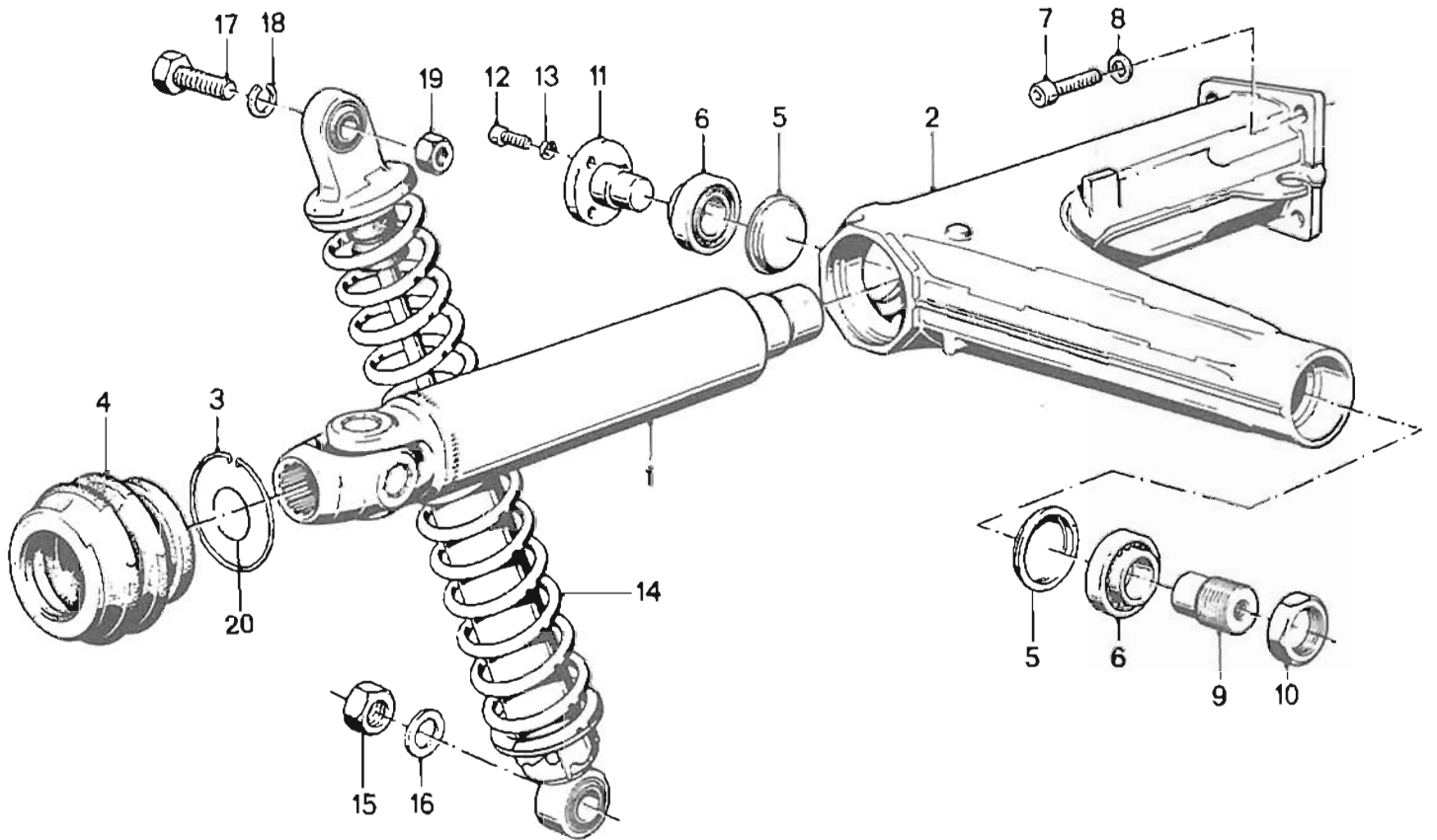

- | | |
|------------------------|--------------------|
| 1 Drive shaft | 11 Bearing journal |
| 2 Rear swinging arm | 12 Machine screw |
| 3 Snap ring | 13 Spring washer |
| 4 Gaiter | 14 Spring strut |
| 5 Cover disc | 15 Hex nut |
| 6 Taper roller bearing | 16 Washer |
| 7 Machine screw | 17 Hex bolt |
| 8 Washer | 18 Spring washer |
| 9 Bearing journal | 19 Hex nut |
| 10 Hex nut | 20 Snap ring |

Rear wheel drive – removing

Remove rear wheel:

Remove the retaining screws (arrows) on the licence plate holder and loosen the hex nuts in the storage compartment.

Pull out the licence plate holder.

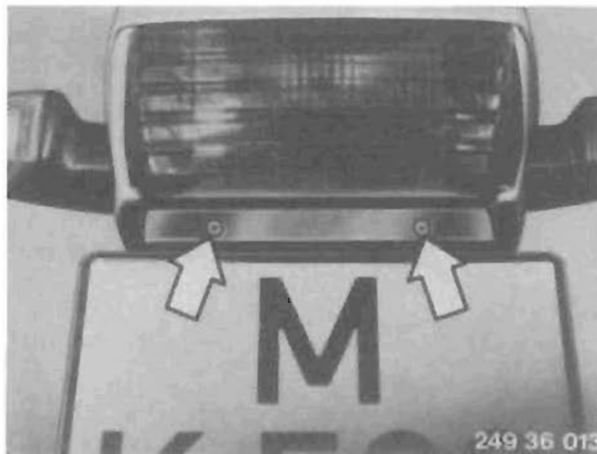

Remove wheel studs, pull off rear wheel and take out.



Lever out cover with a small screwdriver, slacken off wheel studs, pull off rear wheel and take out.

Models with rear disc brake

Note shim.



Remove inductive transmitter:

Remove retaining screw (arrow) for inductive transmitter and pull out transmitter; lever out carefully with a screwdriver if necessary.

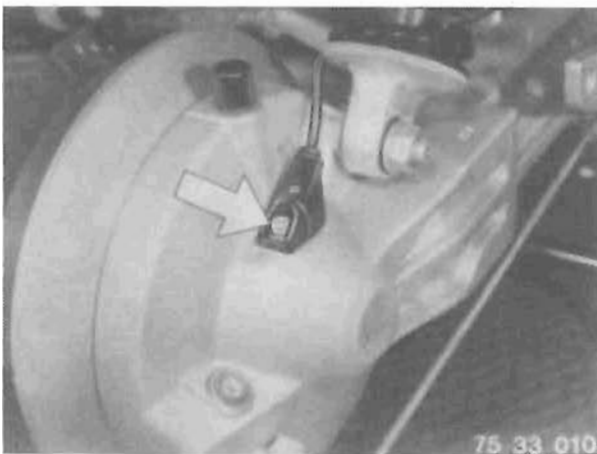

Models with rear drum brake

Remove brake linkage

Remove wing nut (arrow) on brake backplate to dismantle pull rod for rear brake.

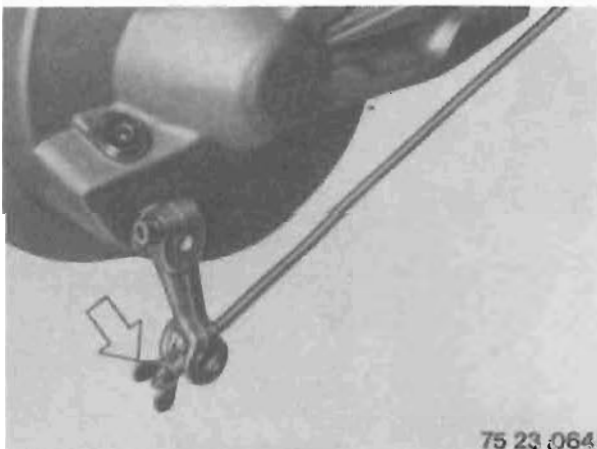

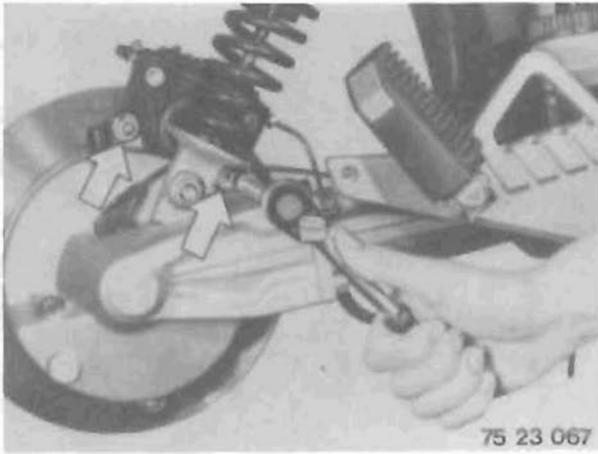

Models with rear disc brake

Remove rear brake:

Remove both brake caliper retaining screws (arrows).
Set down brake caliper with retaining bracket.

Note:

Do not operate the brake pedal while the brake caliper is dismantled.

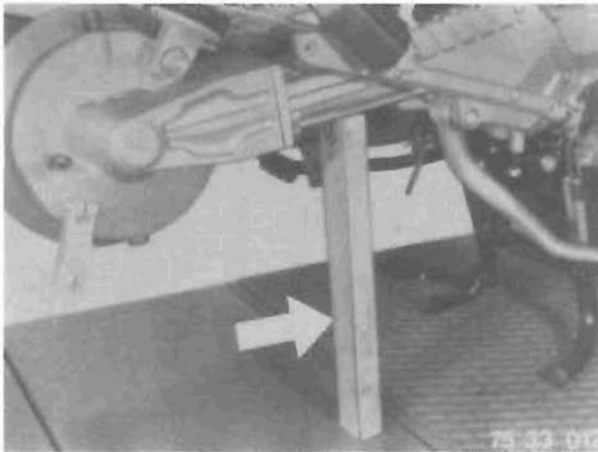

Remove the spring strut:

Note:

Before removing the spring strut, secure the swinging arm in a suitable manner (with wire, a piece of wood, straps etc.) to prevent it from falling.

If the swinging arm is allowed to fall, the rubber drive shaft sleeve will become damaged, allowing contamination and moisture to penetrate and resulting in long-term damage.

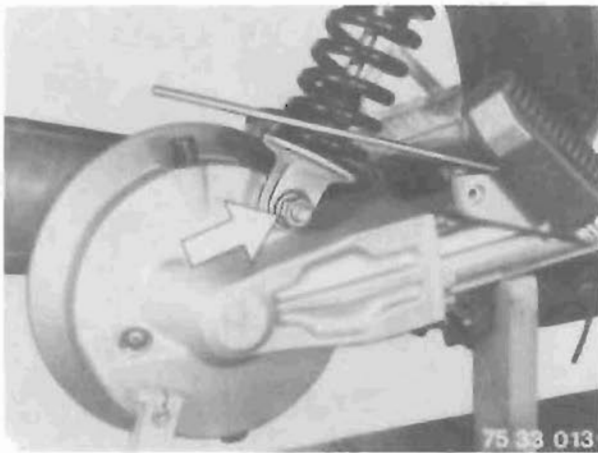

Remove the hex nut (arrow) on the lower spring strut mounting and pull the spring strut off the threaded bolt (slacken off the upper spring strut mounting if necessary).

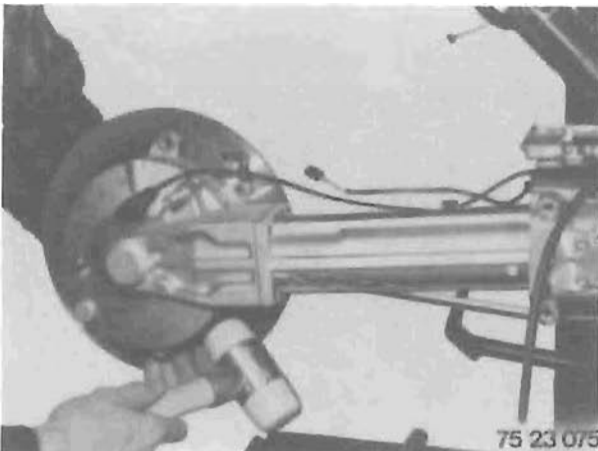

Remove the rear wheel drive:

Remove four rear-wheel drive retaining screws on the swinging arm and pull off the drive (tap rear wheel drive/ swinging arm connection lightly with a plastic mallet if necessary to release).

Rear wheel drive – stripping down

Models with rear drum brake

Remove brake shoes.

Models with rear disc brake

Remove two brake disc retaining screws and take off the brake disc.

Drain off the oil.

Secure the rear wheel drive by the crown wheel in retaining fixture BMW 33 1 500.

Tighten bolts to 100 Nm torque.

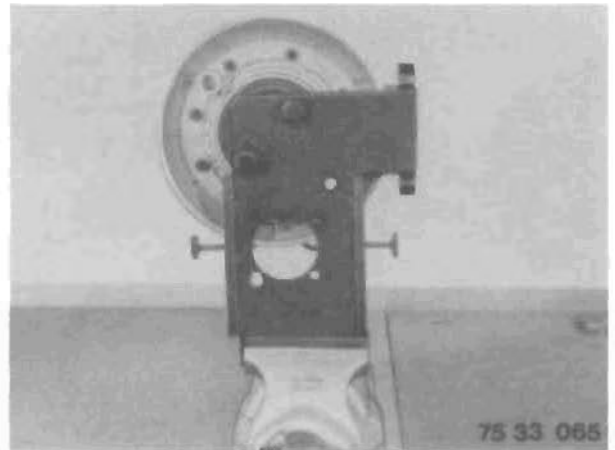

Remove the input bevel pinion

Heat the hex nut on the input bevel pinion to approx. 100°C, and unscrew it.

Never use a hammer to loosen the nut.

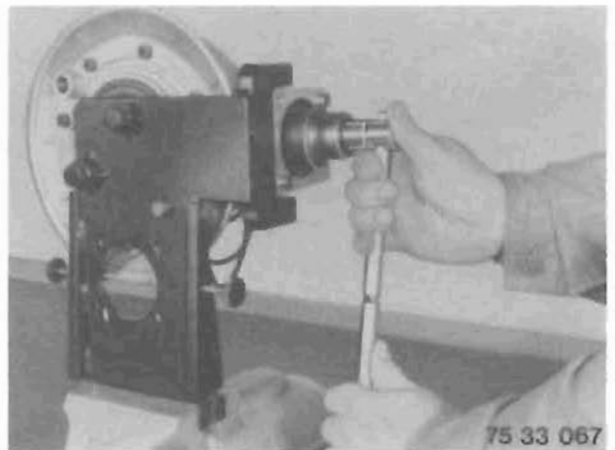

Heat the neck of the housing to approx. 120°C. Loosen the threaded ring with pin wrench BMW 33 1 700 and take it off.

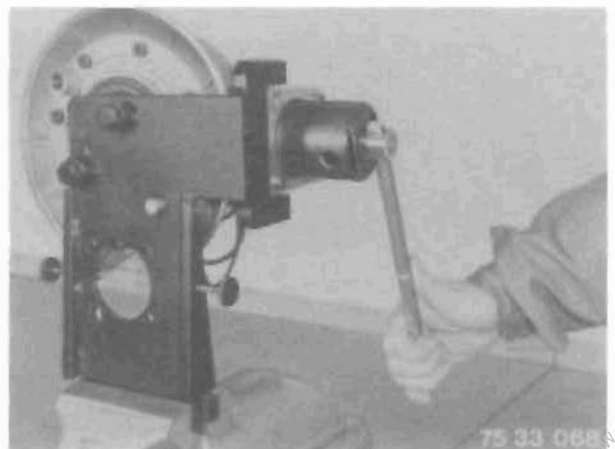

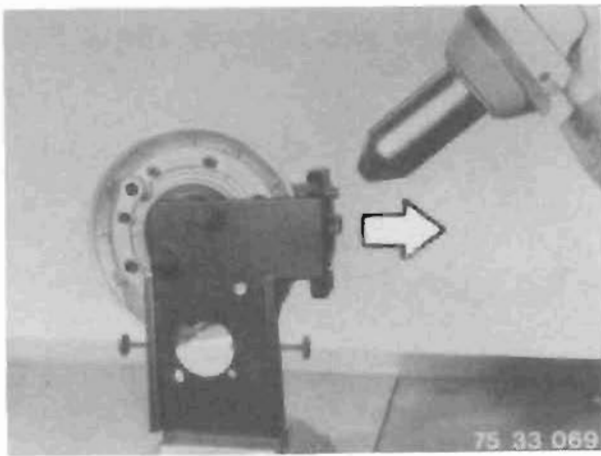

Heat the input bevel pinion bearing seat to 120 ... 130°C and pull out the pinion in the direction of the arrow.

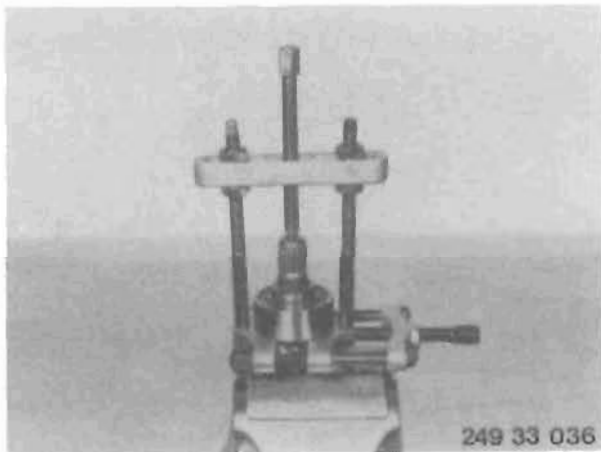

Clamp the input bevel pinion in a vice with protective jaws. Using Kukko puller BMW 00 7 500, pull the ball thrust bearing away from the input bevel pinion.

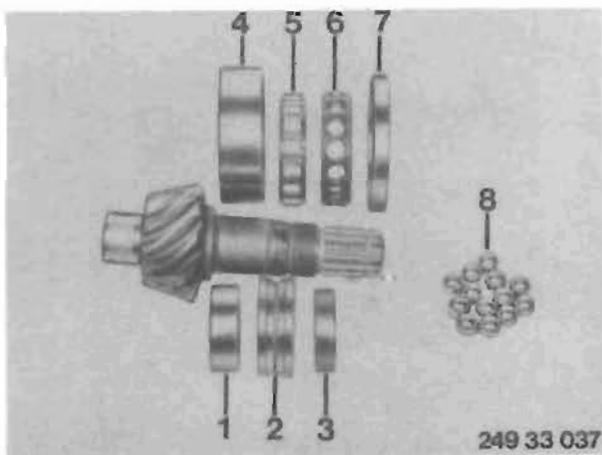

- 1 Inner race, roller bearing
- 2 Inner race, ball bearing
- 3 Thrust ring
- 4 Outer race, roller bearing
- 5 Roller bearing cage
- 6 Ball bearing cage
- 7 Outer race, ball bearing
- 8 Bearing balls

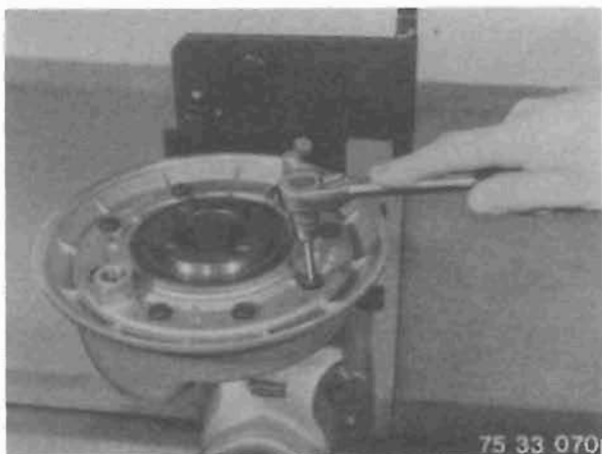

Remove the housing cover

To dismantle the housing cover, reposition the rear wheel drive in the retaining fixture. Remove the cover screws.

Models with rear disc brake

Remove the cover from the housing by applying soft blows with a plastic-faced hammer. Take off the cover with the crown wheel.

Models with rear drum brake

Heat the housing to a temperature of app. 80°C and drive the sleeve for the brake backplate back out of the gear housing cover with arbor, BMW 33 2 640. Remove the cover from the housing by applying soft blows of a plastic-faced hammer. Take off the cover with the crown wheel.



Heat the cover to app. 80°C and pull off the crown wheel.

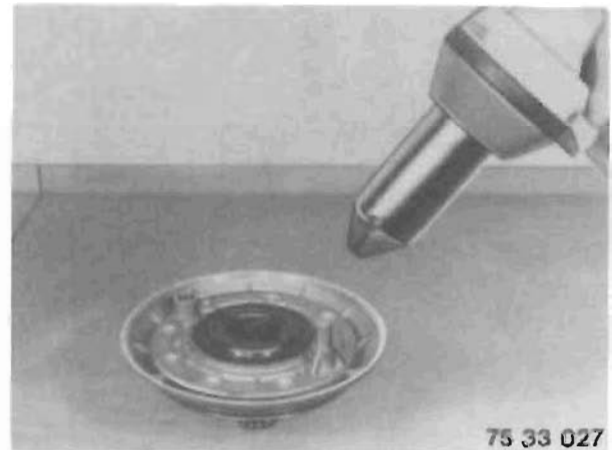

Remove and install shaft sealing ring in gear housing cover.

Drive the shaft sealing ring out of the cover with an arbor. Drive in the new sealing ring with arbor BMW 33 1 860 and handle BMW 00 5 500.



Remove and install bearing shell for taper roller bearing.

Pull the taper roller bearing shell out with Kukko puller BMW 00 8 560.

When installing, heat the housing to 120°C (thermochrome pin).



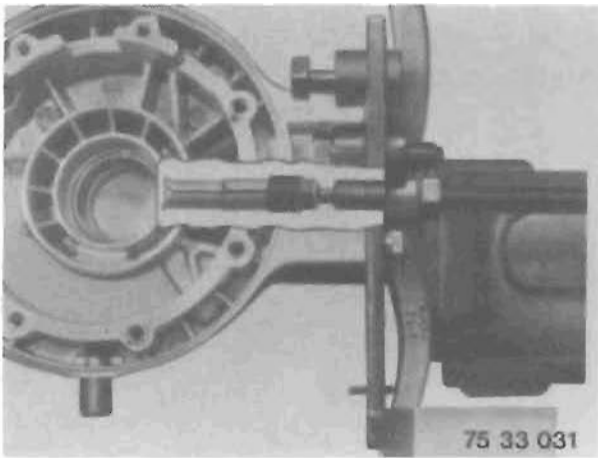

Remove needle roller bearing for input bevel pinion

Heat the housing to approx. 120°C.

Pull the input bevel pinion needle roller bearing out with Kukko puller BMW 00 8 570 or a commercially-available internal bearing puller.

See page 33–20.0.



Removing crown wheel bearing

Secure crown wheel in vice with protective jaws. Insert pressure head BMW 33 1 307.

Attach three-arm puller BMW 33 1 830 to the deep-groove ball bearing and pull it off.

Apply soft hammer blows to the puller spindle head to facilitate removing the bearing.

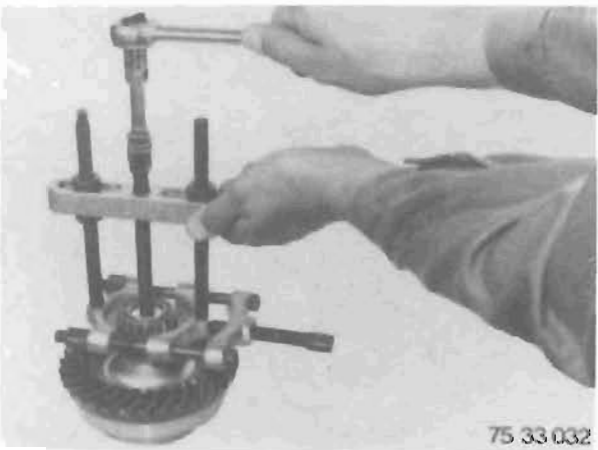

Pull taper roller bearing off crown wheel with universal puller BMW 00 7 500.

Measure and assemble the rear wheel drive

Install the input bevel pinion and crown wheel:

The crown wheel and pinion always form a pair. Note the matching number (arrow).

This number indicates whether the crown wheel and pinion belong together. The values (with tolerances) necessary for smooth running and correct tooth backlash when installed are determined on the test rig.

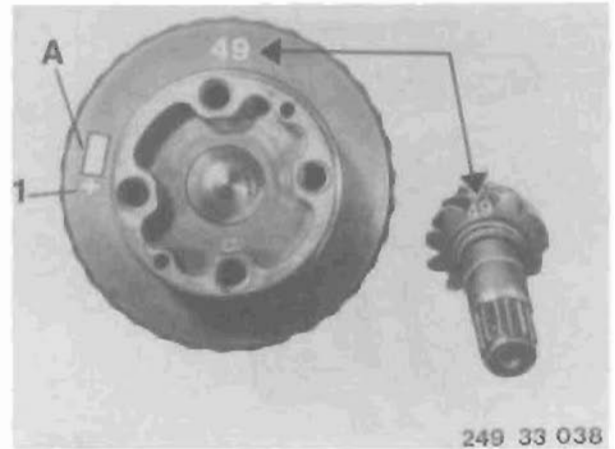

Shim out the input bevel pinion

The standard housing size (G) is 75.50 ± 0.05 mm, measured from the shoulder of the roller and ball bearings at the pinion to the centre of the crown wheel shaft.

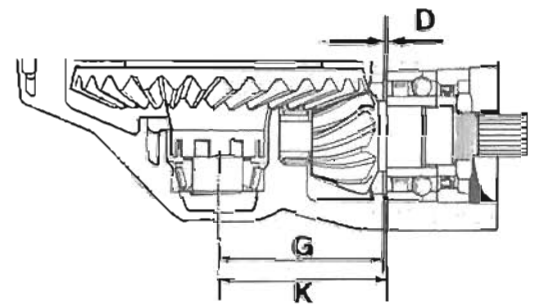

The standard size is not stamped on the housing. If the size of the housing is not standard, two digits representing the deviation in one-hundredths of a millimetre are stamped on the inside of the housing (arrow).

The standard size of the pinion (K) is 77.50 mm. Deviations from this size are stamped + or - in one-hundredths of a millimetre (1) on the crown wheel (see top illustration).

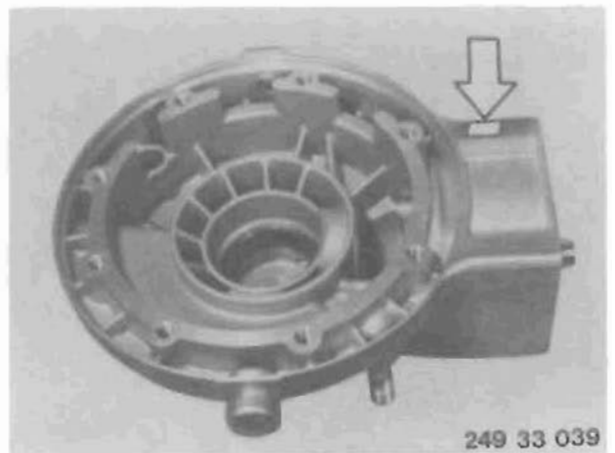

If no deviation (A) is marked on the crown wheel and no measurement is marked on the housing, this means that the standard sizes apply.

In this case the thickness (D) of the ring required is:

$$D = K - G$$

$$D = 77.50 - 75.50 \text{ mm}$$

$$D = 2 \text{ mm.}$$

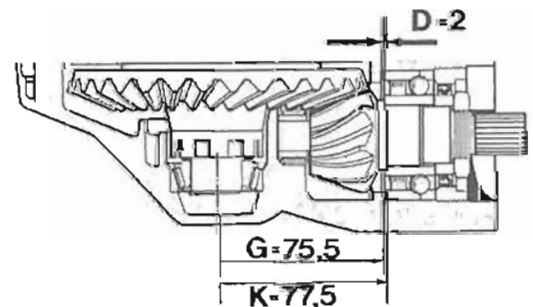

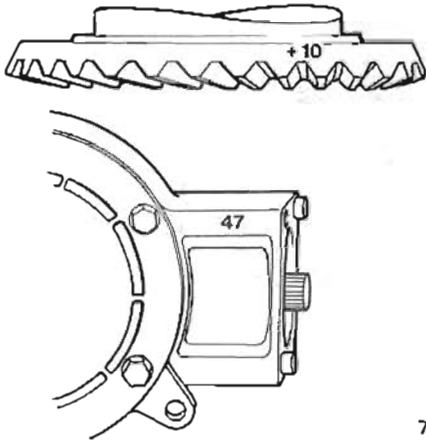

75 33 082

If a deviation (A) is marked on the crown wheel and/or housing, the required ring thickness is calculated as follows:

$$D = K_{(A)} - G_{(A)}$$

$$K_{(A)} = K \pm A$$

$$K_{(A)} = 77.5 + 0.10 \text{ mm (deviation in 1/100 mm on crown wheel)}$$

$$K_{(A)} = 77.6 \text{ mm}$$

$$G_{(A)} = G \pm A$$

$$G_{(A)} = 75.47 \text{ mm (actual dimension in 1/100 mm on housing)}$$

$$D = K_{(A)} - G_{(A)}$$

$$D = 77.6 \text{ mm} - 75.47 \text{ mm}$$

$$D = 2.13 \text{ mm}$$

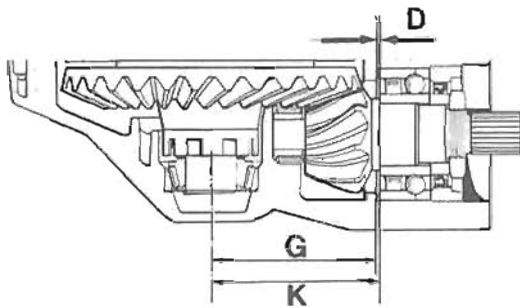

75 33 081 b

Shims are available in 5/100 intervals (see also Technical Data, page 33-03.0).

$D_1 = 2.10 \Rightarrow$ input bevel pinion is nearer centre of housing

$D_2 = 2.15 \Rightarrow$ input bevel pinion projects further out of housing.

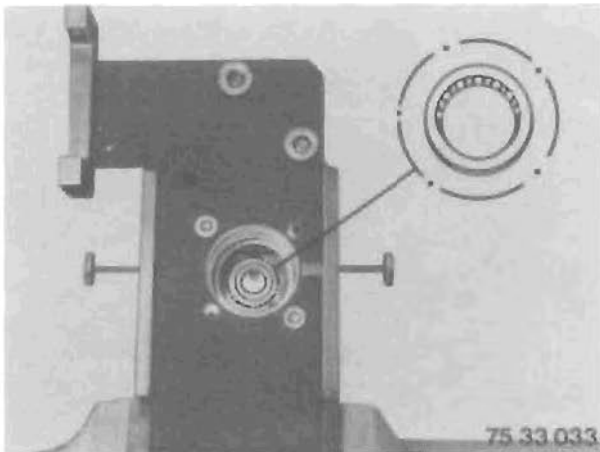

75 33 033

Installing needle roller bearing for input bevel pinion

Clamp rear wheel drive in vice with BMW holder 33 1 630 as illustrated.

Heat up bearing seat in housing to app. 120°C and insert needle roller bearing with the lettering facing outwards.

Note:

Drive in the needle roller bearing with a suitable arbor or input bevel pinion.

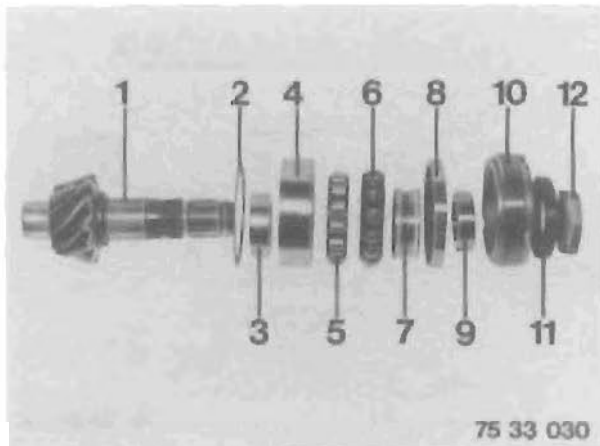

75 33 030

Install the input bevel pinion

Fit the ball thrust bearing on the input bevel pinion.

Heat up the inner race for roller bearing (3) to app. 120°C and fit on the input bevel pinion. Place outer race for roller bearing (4) on inner race together with roller cage (5).

Heat inner ring (7) for ball bearing to app. 120°C and fit on input bevel pinion. Allow input bevel pinion to cool down.

Insert a shim of appropriate thickness.

Heat neck of housing to app. 120°C.

Fit input bevel pinion with assembled ball thrust bearing.
Place outer race (8) (see top illustration) for ball bearing on ball cage.

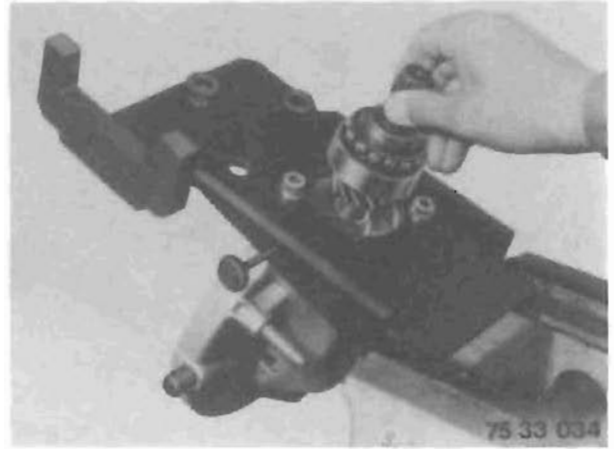

Remove and install shaft sealing ring in threaded ring

Push shaft sealing ring out of threaded ring.

Drive in new sealing ring with BMW arbor 33 1 760 and handle BMW 00 5 500.

Note:

Lettering should face outwards.



Screw in threaded ring:

Housing temperature should be at least 80-100°C.

Threads must be free from oil and grease. Apply Hylomar SQ 37 to threaded ring.

Screw in threaded ring with journal key BMW 33 1 700.

Note:

Ensure that the sealing lip of the shaft sealing ring is correctly located on the thrust ring.

Tightening torque:

Threaded ring $118 \pm 12 \text{ Nm}$



Screw in hex nut:

Apply app. 0.1 g Loctite 273 to the hex nut. Affix hex nut and tighten against thrust ring.

Screw in oil drain plug with new sealing ring.

Warning:

Nut must not be allowed to damage shaft sealing ring.

Tightening torques:

Nut for input bevel pinion $200 \pm 20 \text{ Nm}$

Drain plug $25 \pm 3 \text{ Nm}$

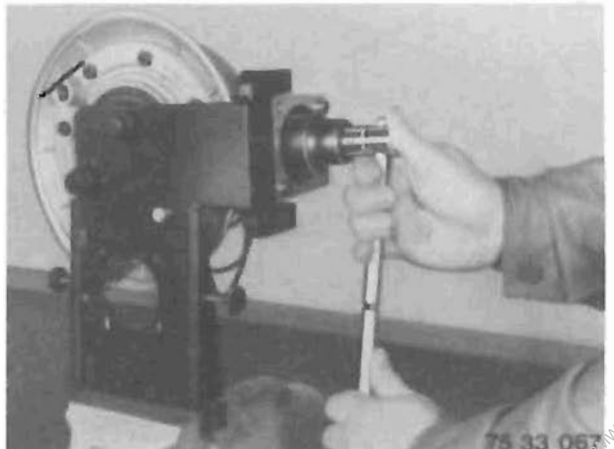

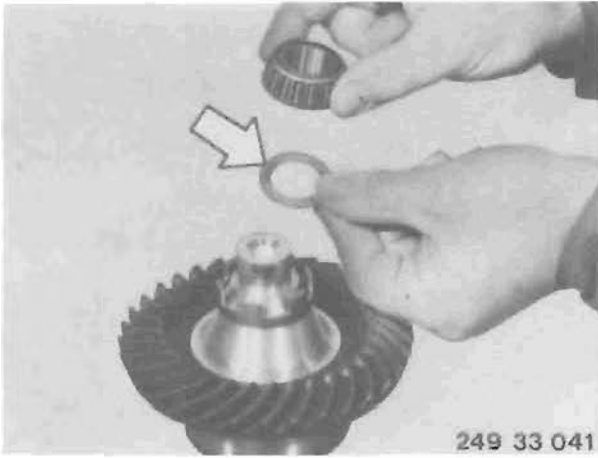

Shim out the crown wheel

(Calculate tooth backlash):

To achieve correct preliminary tooth backlash, insert a 2.35 mm spacing ring (arrow) under the ball and roller bearing.

When installing:

The chamfer on the inside diameter must face down (towards crown wheel).

Heat the bearing up to app. 80°C to assemble.



Fit the deep-groove ball bearing:

Heat the deep-groove ball bearing up to app. 80°C and fit to bearing seat.

Install the crown wheel in rear wheel drive housing.

Use BMW 33 2 600 measuring device to adjust the tooth backlash.

With the crown wheel installed, place measuring ring (1) with dial gauge holder (2) on the rear wheel drive housing.

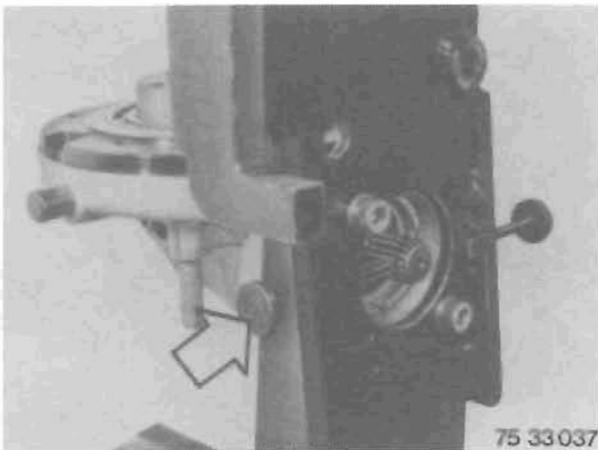

For accurate tooth backlash measurement, the pinion must be prevented from moving with the locking screw (arrow).

Warning:

Housing must have cooled down again to room temperature.

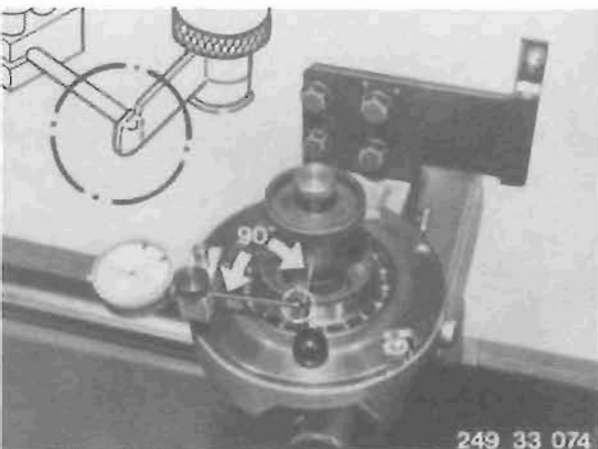

Secure the measuring stop BMW 33 2 604 in the crown wheel so that the dial gauge feeler is at the mark on the stop and at a right angle to it.

Move the crown wheel lightly to and fro at the measuring stop. Release the measuring stop and turn the crown wheel to check the tooth backlash at 3 points (3 times at 120° intervals).

Tooth backlash
(setting without oil):

0.07 ... 0.16 mm

If tooth backlash is too small or too great, insert a thicker or thinner spacing ring (arrow) as appropriate.

When installing:

The chamfer on the inside diameter of the spacing ring must face towards crown wheel.

See Technical Data, page 33–03.0, for spacing ring thicknesses.

Check the contact face pattern between crown wheel and input bevel pinion:

To check the contact face pattern apply a coat of engineer's blue or a light-coloured oilbound paint to a few teeth. Insert the crown wheel in the housing and turn it a few times to and fro while exerting strong pressure on the wheel.

If the resulting contact face pattern is as illustrated here, the bevel pinion is too deep inside the housing and a thicker spacing ring must be installed ...

... so that this contact pattern is achieved.

If this pattern results, the pinion must be moved further inside the housing by inserting a thinner spacing ring ...

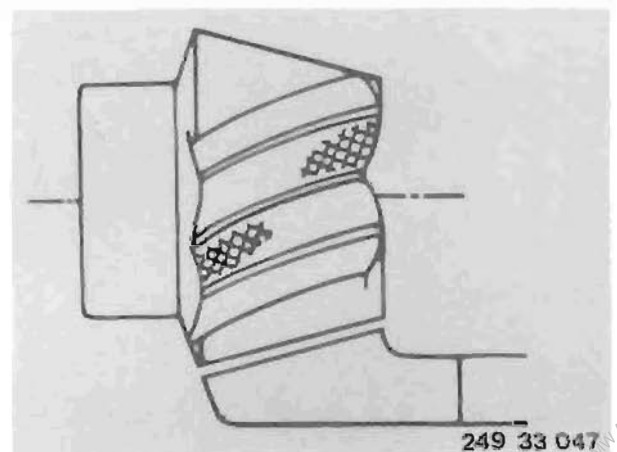
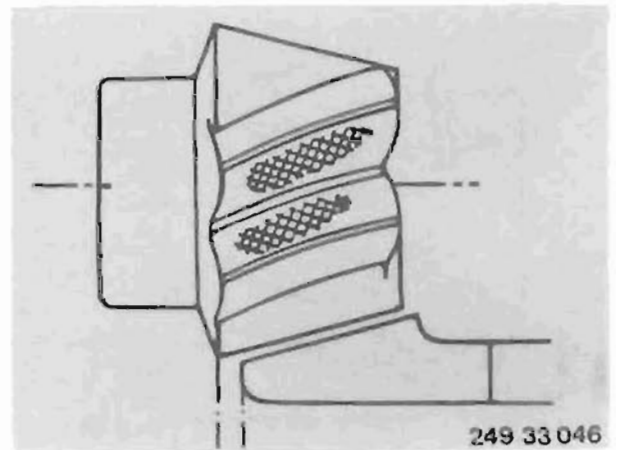
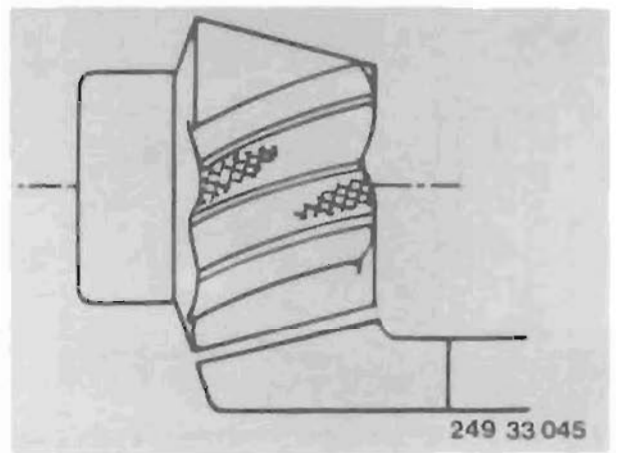
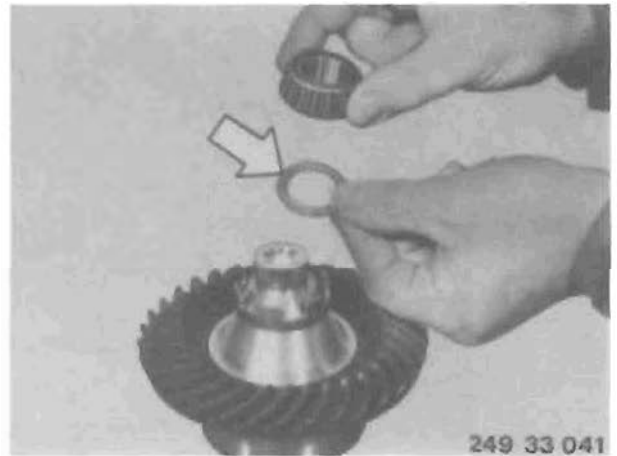

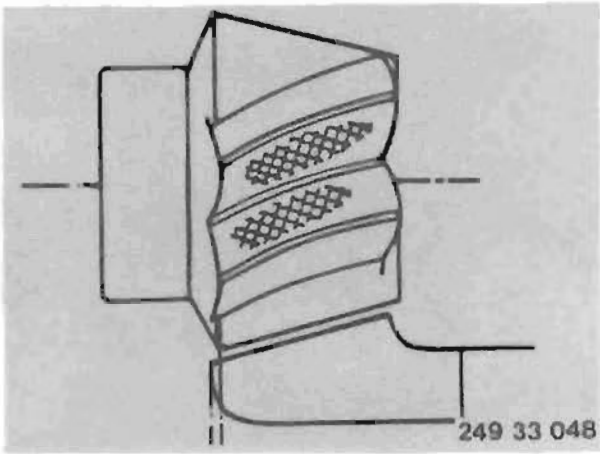

... so that this contact pattern is achieved.

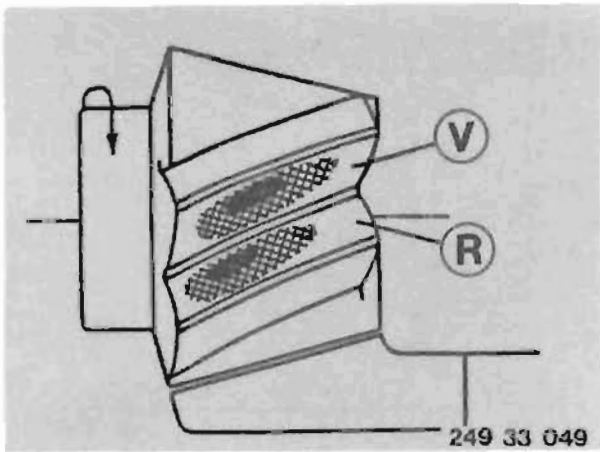

Correct contact pattern off-load:
 Contact face at centre of leading flank "V"
 Contact face nearer the large diameter on trailing flank "R"
 The teeth must **never** make contact at the small diameter in any circumstances.

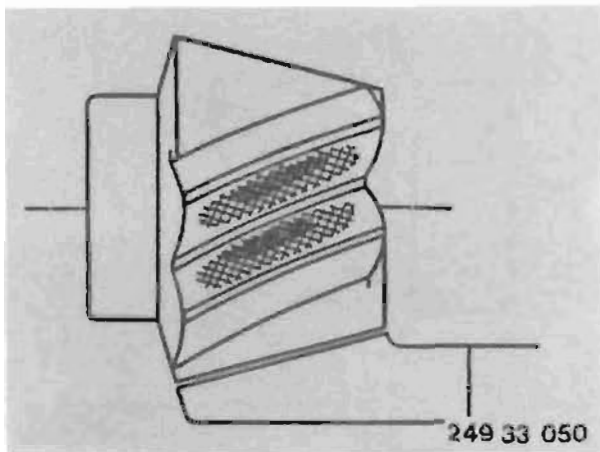

The following pattern is then obtained under load.

Calculate preload at taper roller bearing

Comply with the following procedure to achieve the necessary taper roller bearing preload or friction coefficients:

Measure distance "m" from the contact surface of the cover to the ball bearing seat.

Deduct the size of the spacer blocks "h" (arrows) from the measured value "m"!

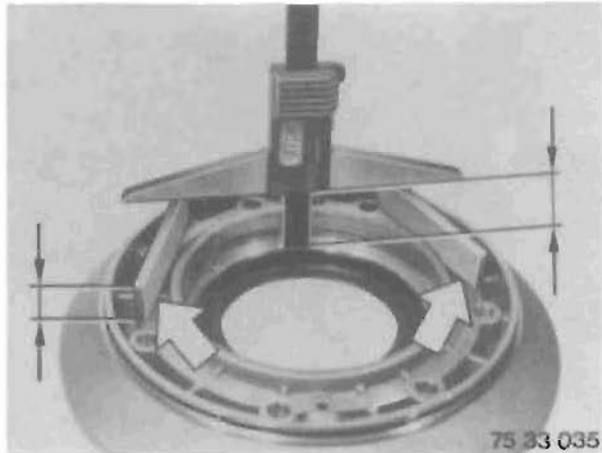

75 33 035

Measure distance "h" from the ball bearing outer race through the window in the measuring ring to the contact surface of the cover with depth gauge.

Subtract measurement "m" from measurement "h" to arrive at the required shim washer tickness without preload.

To achieve the required taper roller bearing preload, a thicker spacing ring must be fitted.

See Technical Data, page 33 – 03.0 for table of spacer sizes.

Taper roller bearing preload: 0.05 ... 0.1 mm
($\hat{=}$ app. 600 – 1600 N preload force)



75 33 036

m measure
– h measure
= d
– g measure
= play without preload
+ specified preload
= spacing ring thickness

Install housing cover

Check cord ring seal for damage and renew if necessary. Grease cord ring seal slightly before installing.

Heat up housing cover gently to app. 80°C and fit to housing.

Tighten retaining screws for housing cover in a crosswise pattern.

Tightening torque:

Housing cover retaining screws 21 ± 2 Nm

Models with rear drum brake:

Drive bushing for brake backplate into housing cover with arbor BMW-Nr. 33 2 640.

Fill with gear oil (see Technical Data).

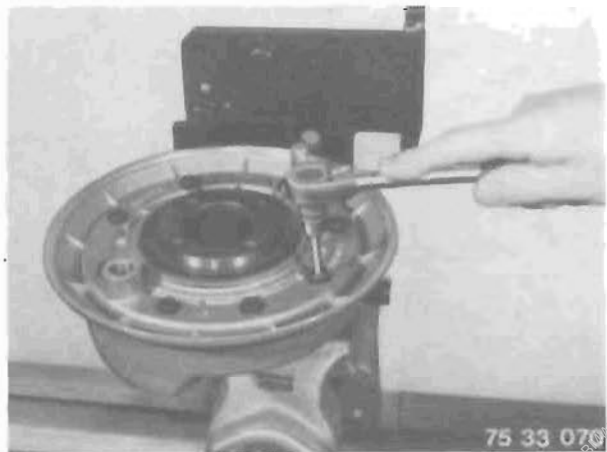

75 33 070

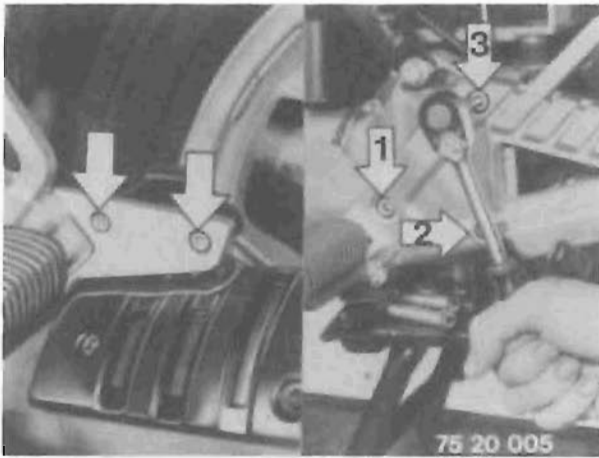

Rear swinging arm – removing

Remove both silencer retaining screws (arrows) on left-hand footrest plate.

Remove retaining screws (arrows 1, 2, 3) on left-hand footrest plate and take off footrest plate.

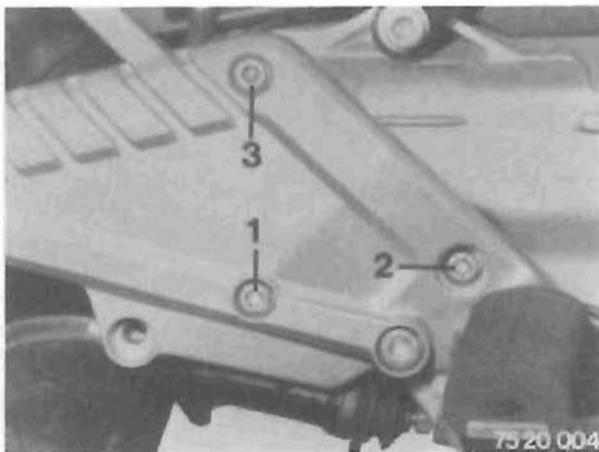

Remove retaining screws (1, 2, 3) for right-hand footrest plate. Set down footrest plate.

Lift clutch cable out of withdrawal arm.

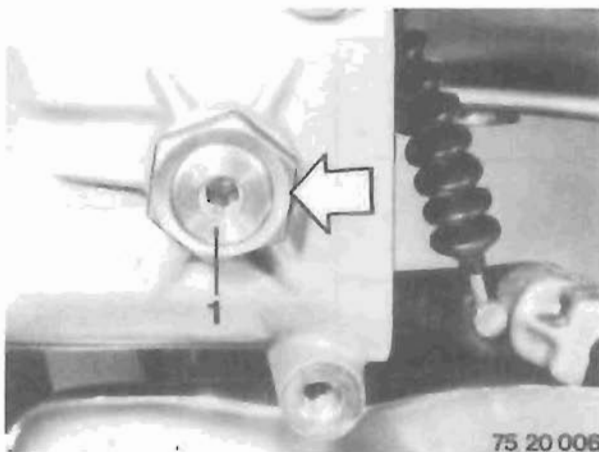

Remove left-hand swinging arm bearing:

Remove bearing journal locking nut (arrow).

Unscrew bearing journal (1) with 6 mm Allen key.

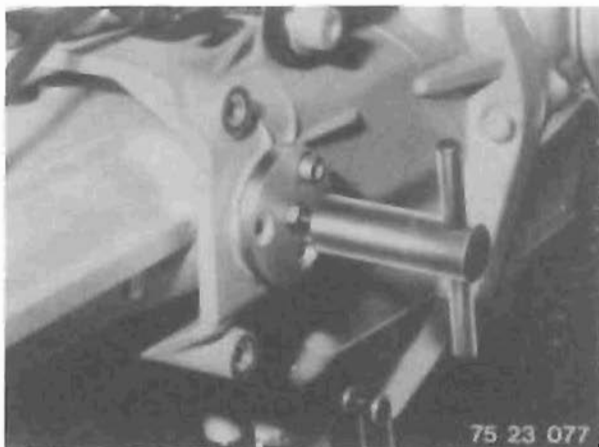

Remove three retaining screws for swinging arm fixed bearing.

Remove two screws.

Insert BMW extractor 26 1 660 in fixed bearing centre hole and lock in position.

Unscrew the third retaining screw.

Pull out fixed bearing with a slight turning action.

Take out the swinging arm.

Drive shaft – removing

Lever drive shaft off snap ring with a screwdriver and pull off gearshaft.

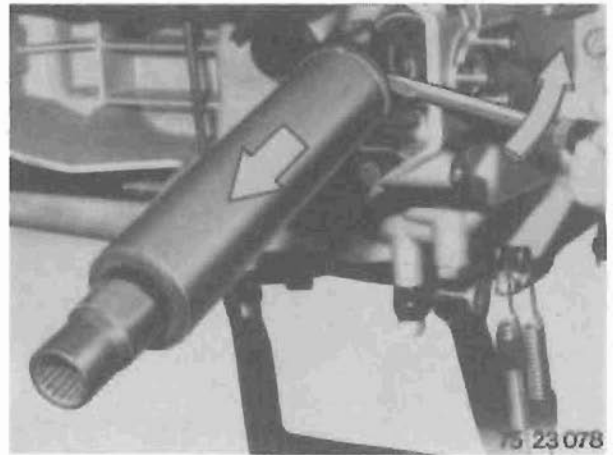

Universal joint – checking for wear

Twist both drive shaft sections to and fro to determine radial play and slide longitudinally to determine endplay. Renew the drive shaft if necessary.

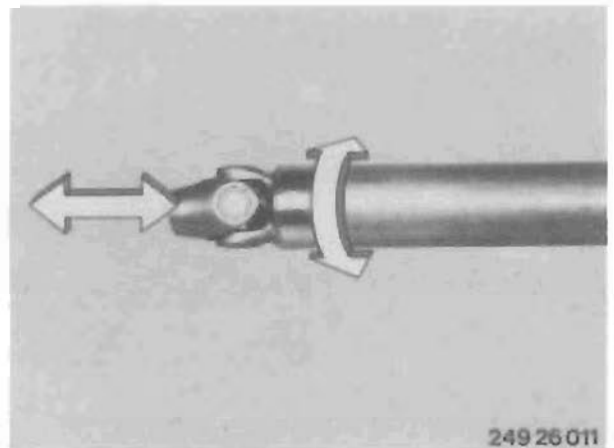

Drive shaft snap ring – removing and installing

Lever snap ring out of groove with small screwdriver and press down towards the universal joint. Take out the snap ring through the universal joint (left picture). Introduce a new snap ring in the universal joint and press up into the groove with a screwdriver (right picture).

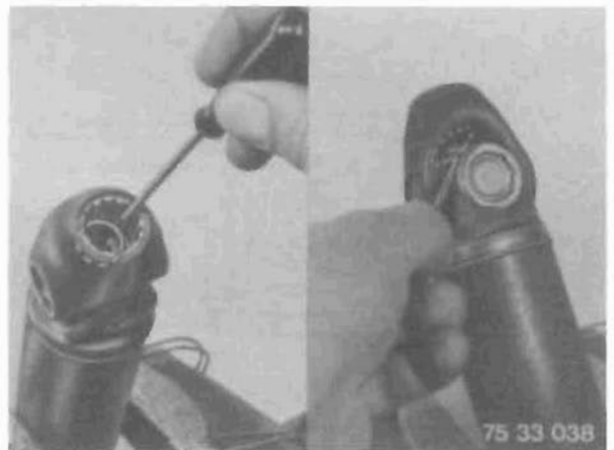

Rear swinging arm taper roller bearing – removing and installing

Pull out taper roller bearing together with sealing ring and cover ring using Kukko puller 21/3 and support 22-1, BMW 00 8 572.



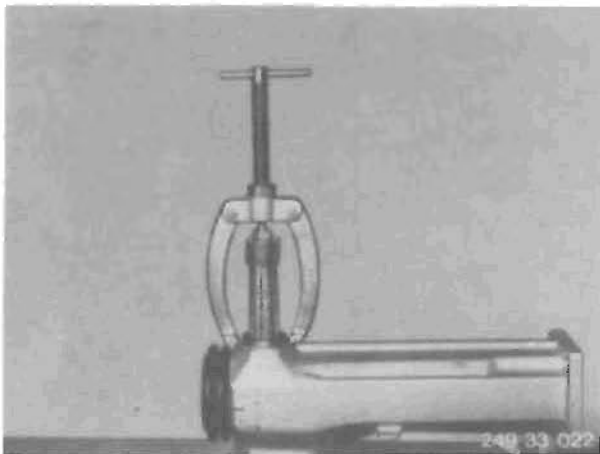

Pull out bearing shell with Kukko puller BMW 00 8 551 and support bridge BMW 00 8 560.

When installing:

Grease the bearing sufficiently before installing.

Heat up the swinging arm to app. 80°C.

Drive in a new taper roller bearing with a suitable pipe, exterior diameter 39,0 mm, interior diameter 34 mm.

Drive in cover ring.

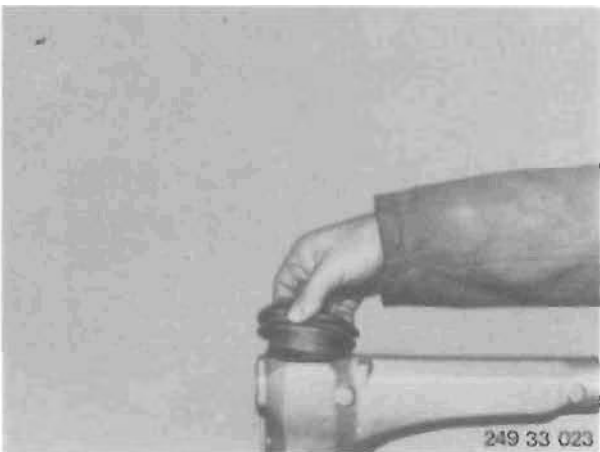

Sealing sleeve between swinging arm and gearbox – removing and installing

Pull gaiter out of swinging arm and remove circlip.

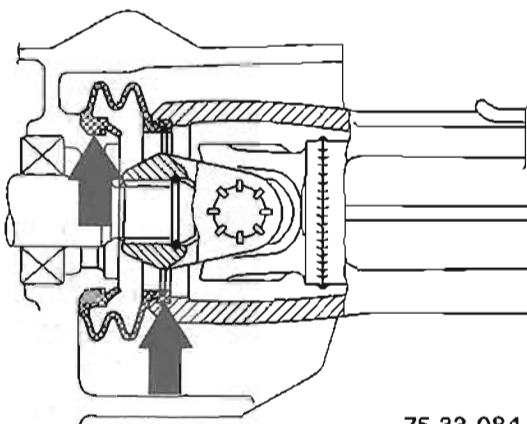

Apply Staburags NBU 30 PTM or Optimoly Paste PL to the outer and inner sealing surfaces of the gaiter (arrows). Install the gaiter the correct way round in the swinging arm.

75 33 084

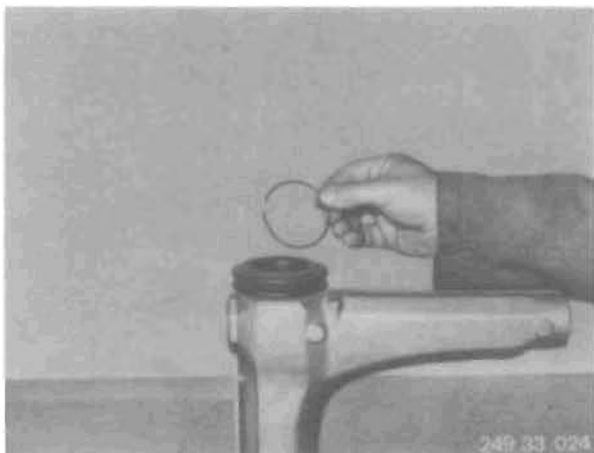

Install the circlip (1) in such a way that the opening faces the rib (2) on the swinging arm cross-tube.

Rear swinging arm – installing

Coat output shaft splines and inside of rubber bushing with Staburags NBU 30 PTM or Optimoly Paste PL. Press swinging arm on gear housing without drive shaft, with a slight to and fro twisting action. Carefully pull back to check whether the rubber bushing has engaged in the gear housing.

Note:

Never fit the swinging arm with the rear wheel drive fitted, as the bushing will not be able to engage in position.

Warning:

Be sure to prevent the swinging arm from falling.

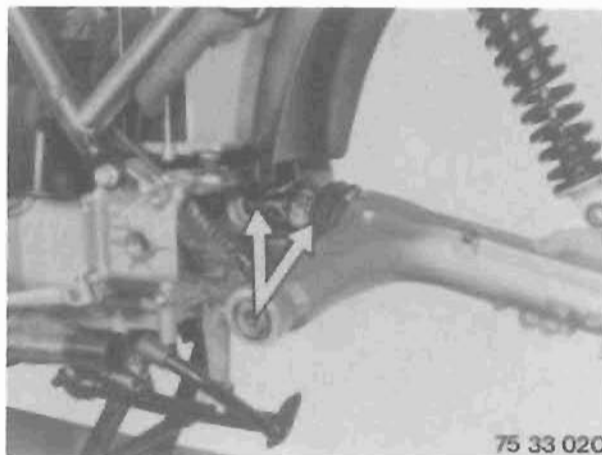

Coat swinging arm fixed bearing journal (11) with "Never-Seez".

Insert swinging arm fixed bearing journal in the swinging arm mounting with a slight twisting action using BMW puller 26 1 660, and tighten the three retaining screws.

Tightening torque:

Swinging arm fixed bearing $9 \pm 1 \text{ Nm}$

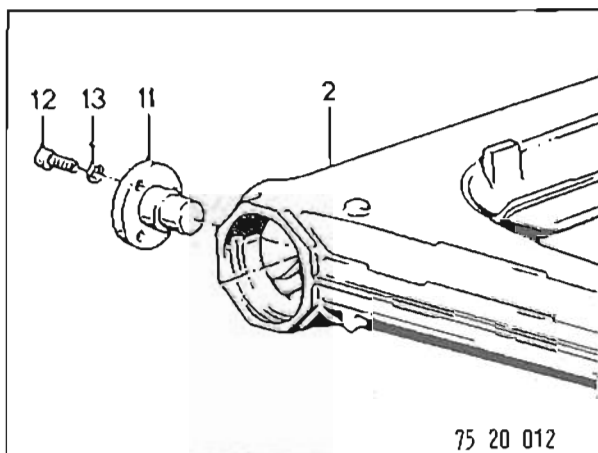

Coat swinging arm moving bearing journal (11) with "Never-Seez".

Pull swinging arm towards swinging arm moving bearing. Insert bearing journal and screw into the gear housing by hand.

Tighten bearing journal with a torque wrench. Screw on locking nut (1) and tighten with torque wrench.

Tightening torques:

Bearing journal $7.5 \pm 0.5 \text{ Nm}$

Locking nut $41 \pm 3 \text{ Nm}$

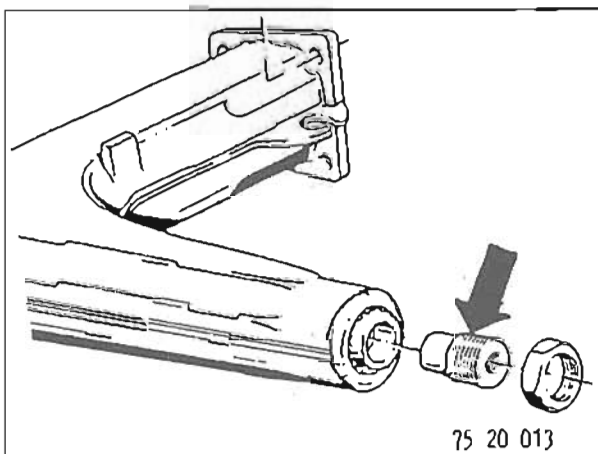

Drive shaft – installing

Coat drive shaft splines with Staburags NBU 30 PTM or Optimoly Paste PL.

Introduce drive shaft in swinging arm and push across the splines.

The snap ring must be heard to locate in position.

Connect up clutch cable to withdrawal arm.



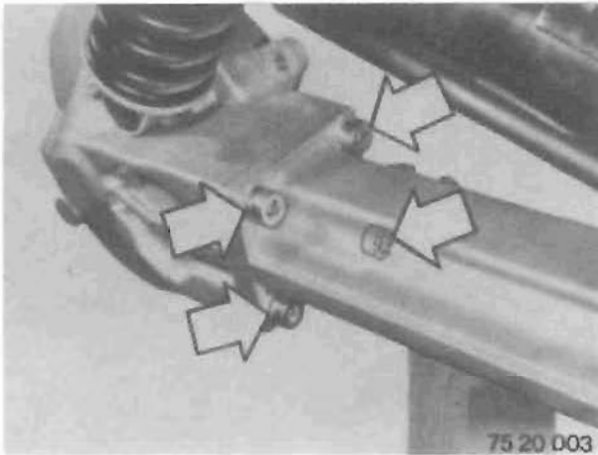

Rear wheel drive – Installing

Coat input bevel pinion splines with Staburags NBU 30 PTM or Optimoly Paste PL.
Fit rear wheel drive on rear swinging arm and secure with four retaining screws.

Tightening torque:

Rear wheel drive retaining screws $40 \pm 3 \text{ Nm}$

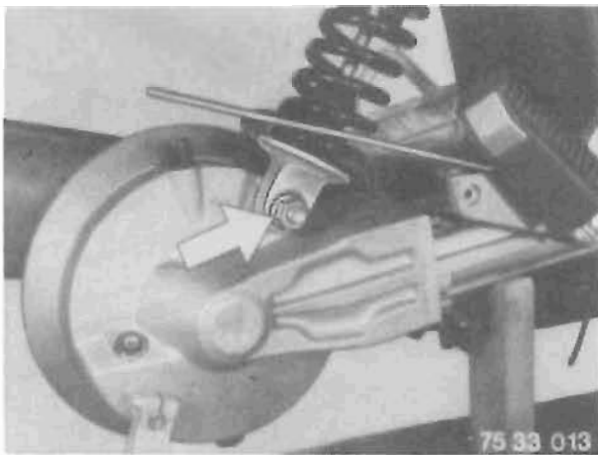

Push spring strut over mounting pin.

Fit washer and hex nut.

Tighten spring strut retaining screws at top and bottom.

Tightening torque:

Spring strut mounting at top and bottom $51 \pm 3 \text{ Nm}$

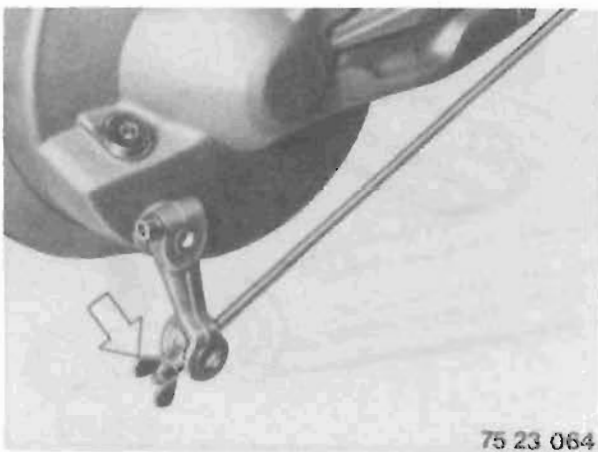

Models with rear drum brake

Introduce pull rod through brake backplate. Screw on wing nut.

Turn rear wheel, screwing in pull rod wing nut until the rear wheel is just braked. Then slacken the wing nut through 3-4 revolutions (equivalent to app. 25 mm footbrake pedal play).

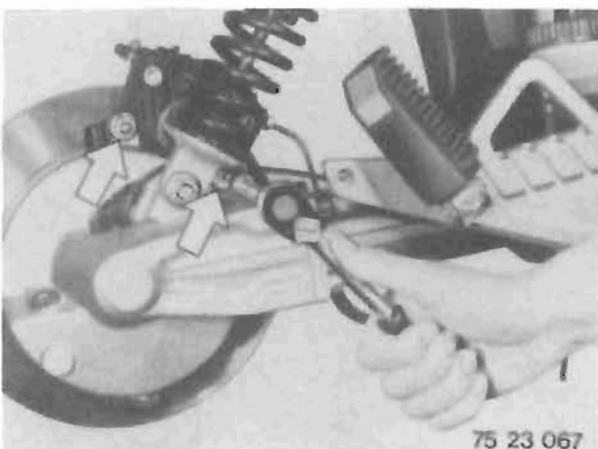

Models with rear disc brake

Fit brake caliper on brake disc.

Screw on retaining screws with a washer behind and mounting bracket in front, and tighten.

Tightening torque:

Brake caliper retaining screws $32 \pm 2 \text{ Nm}$

Install inductive transmitter:

Coat sealing ring (1) with SAE 90 hypoid oil before installing.

Warning:

Inductive transmitter (2) must not rub against transmitter sleeve (3). Tighten inductive transmitter with retaining screw.

Tightening torque:

Retaining screw for inductive transmitter $2.5 \pm 0.5 \text{ Nm}$

Add oil to rear wheel drive

Filling capacity 0.26 l

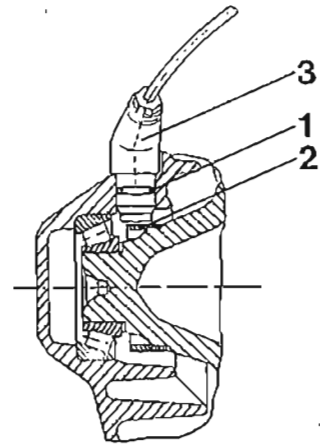

75 33 089

Install rear wheel:

The centre hub and wheel hub contact surfaces must be scrupulously clean and free from grease.

Warning:

Models with rear drum brake

Only use 55 mm long wheel studs (see head of stud).

Models with rear disc brake

Only use 60 mm long wheel studs (see head of stud).

Tightening torque:

Wheel studs $105 \pm 4 \text{ Nm}$



34

Brakes

34 Brakes

Specifications	Page 34-03.0
Tightening torques	34-05.0
Diagrams	34-06.0
Brake fluid – changing (front and rear)	34-10.0
Front brake pads – removing and installing	34-12.0
Front brake caliper – removing and installing	34-12.0
Rear brake pads – removing and installing	34-13.0
Rear brake caliper – removing and installing	34-13.0
Main rear brake cylinder – removing and installing	34-14.0
Brake blocks – removing	34-15.0
Brake blocks – installing	34-15.0
Rear drum brake – installing	34-16.0
Rear brake disc – removing and installing	34-16.0
Front brake disc – removing and installing	34-17.0
Footbrake pedal – removing and installing	34-18.0
Footbrake light switch – removing and installing	34-19.0
Handbrake light switch – removing and installing	34-20.0

Brakes**Tightening torques**

Connection	Nm
Brake caliper to sliding tube / rear wheel drive	32 ± 2
Brake pipe to brake caliper	7 ± 1
Brake hose to brake pipe	7 ± 1
Hollow screw for brake hose on distributor pipe	7 ± 1
Distributor pipe to fork bridge	10 ± 1
Brake hose to distributor pipe	7 ± 1
Brake hose to main brake cylinder	11 ± 1
Brake disc to front wheel	29 ± 3
Retaining screw on quick-release axle	33 ± 4
Clamping screw on quick-release axle	14 ± 2
Brake disc to rear wheel drive	21 ± 2
Wheel studs (rear)	105 ± 4
Footbrake lever to footrest plate	25 ± 3
Main brake cylinder to footrest plate	6 ± 1
Adjusting screw on main brake cylinder	18 ± 2
Bleed screw	7 ± 1

Front brake lines

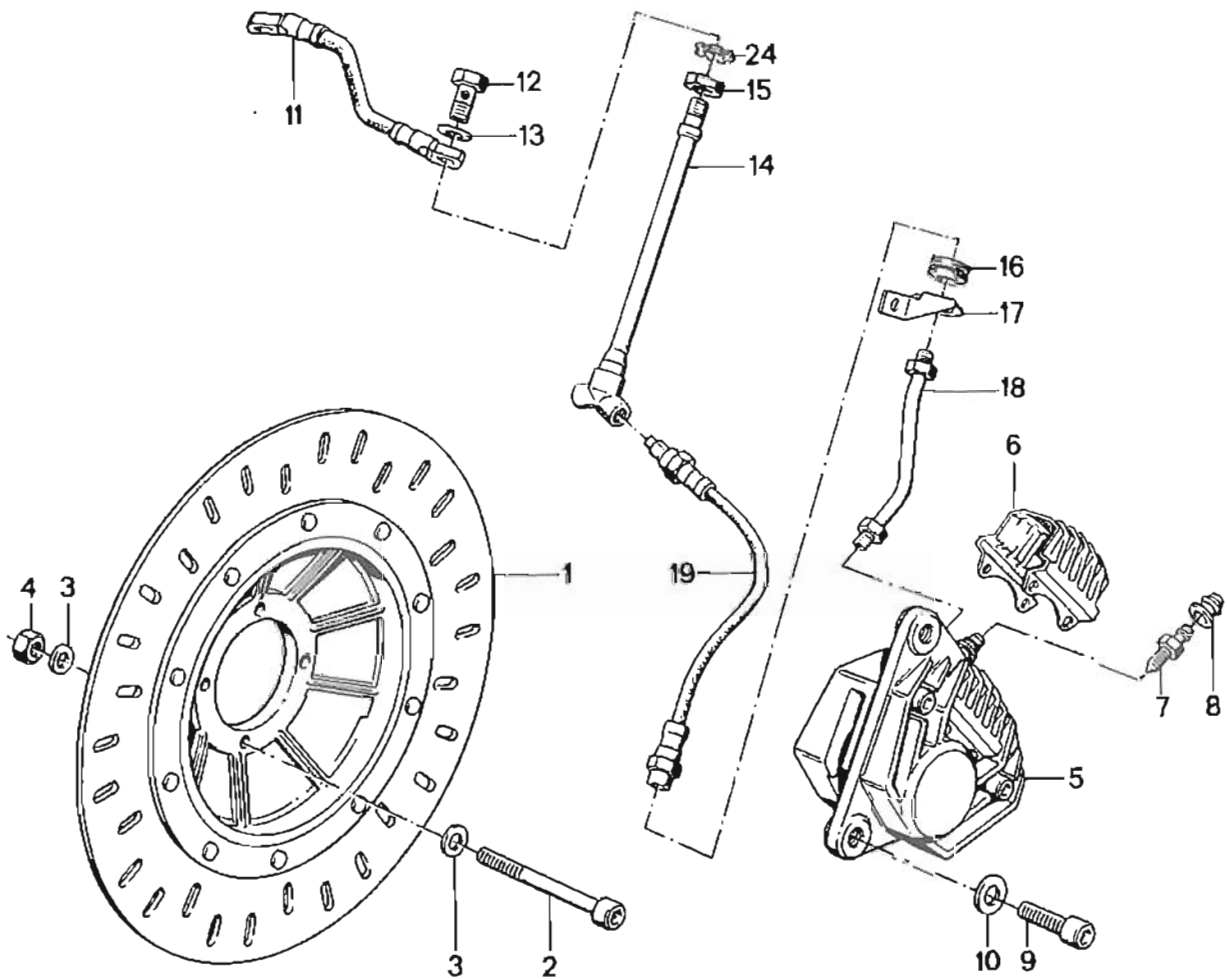

- 1 Brake disc
- 2 Retaining screw
- 3 Washer
- 4 Nut
- 5 Brake caliper
- 6 Cover cap
- 7 Bleed screw
- 8 Dust cap
- 9 Retaining screw
- 10 Washer

- 11 Brake hose
- 12 Hollow screw
- 13 Sealing ring
- 14 Distributor pipe
- 15 Plastic nut
- 16 Toothed washer
- 17 Mounting bracket
- 18 Brake pipe
- 19 Brake hose

- 24 Toothed washer

Right handlebar, brake cylinder

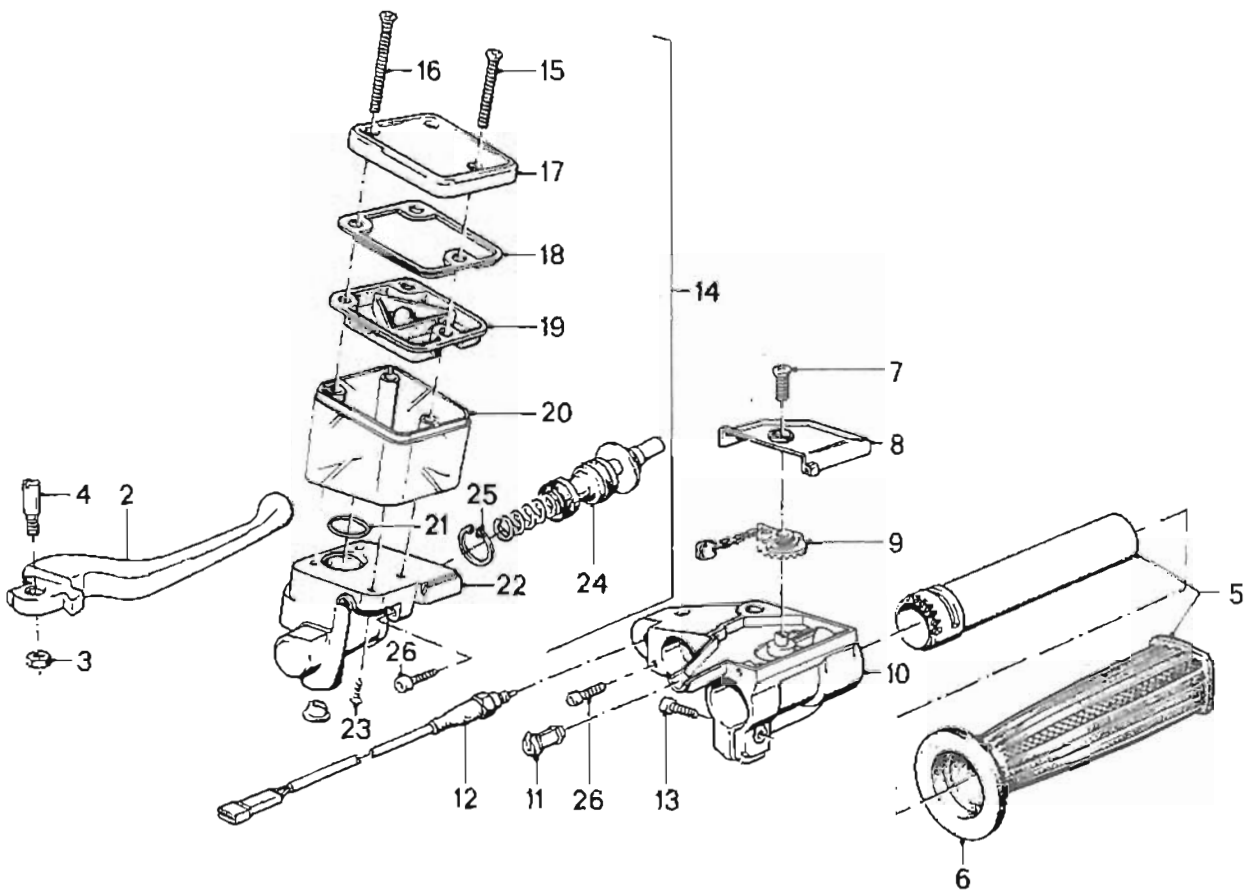

2 Lever
3 Hex nut
4 Headless screw

14 Cylinder with piston
15 Countersunk screw
16 Countersunk screw
17 Cover
18 Spacer
19 Rubber gaiter

20 Reservoir
21 O-ring
22 Cylinder
23 Screw
24 Piston
25 Circlip
26 Machine screw

Rear brake master cylinder

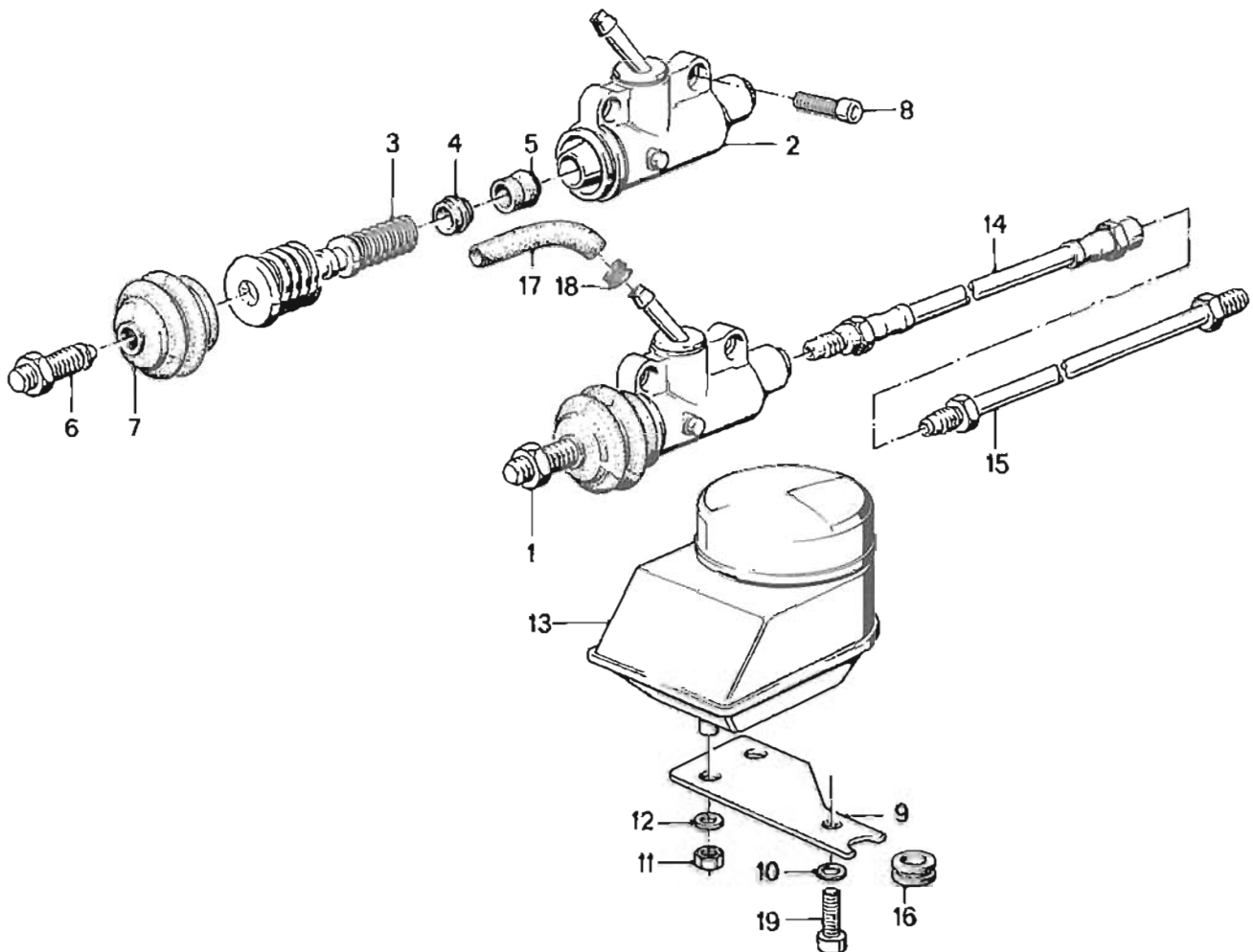

- | | |
|-------------------------|------------------|
| 1 Brake master cylinder | 11 Hex nut |
| 2 Housing | 12 Washer |
| 3 Buffer | 13 Reservoir |
| 4 Seal | 14 Brake hose |
| 5 Bushing | 15 Brake pipe |
| 6 Adjusting screw | 16 Sleeve |
| 7 Flexible gaiter | 17 Hose |
| 8 Machine screw | 18 Hose clip |
| 9 Mounting plate | 19 Machine screw |
| 10 Washer | |

Rear drum brake

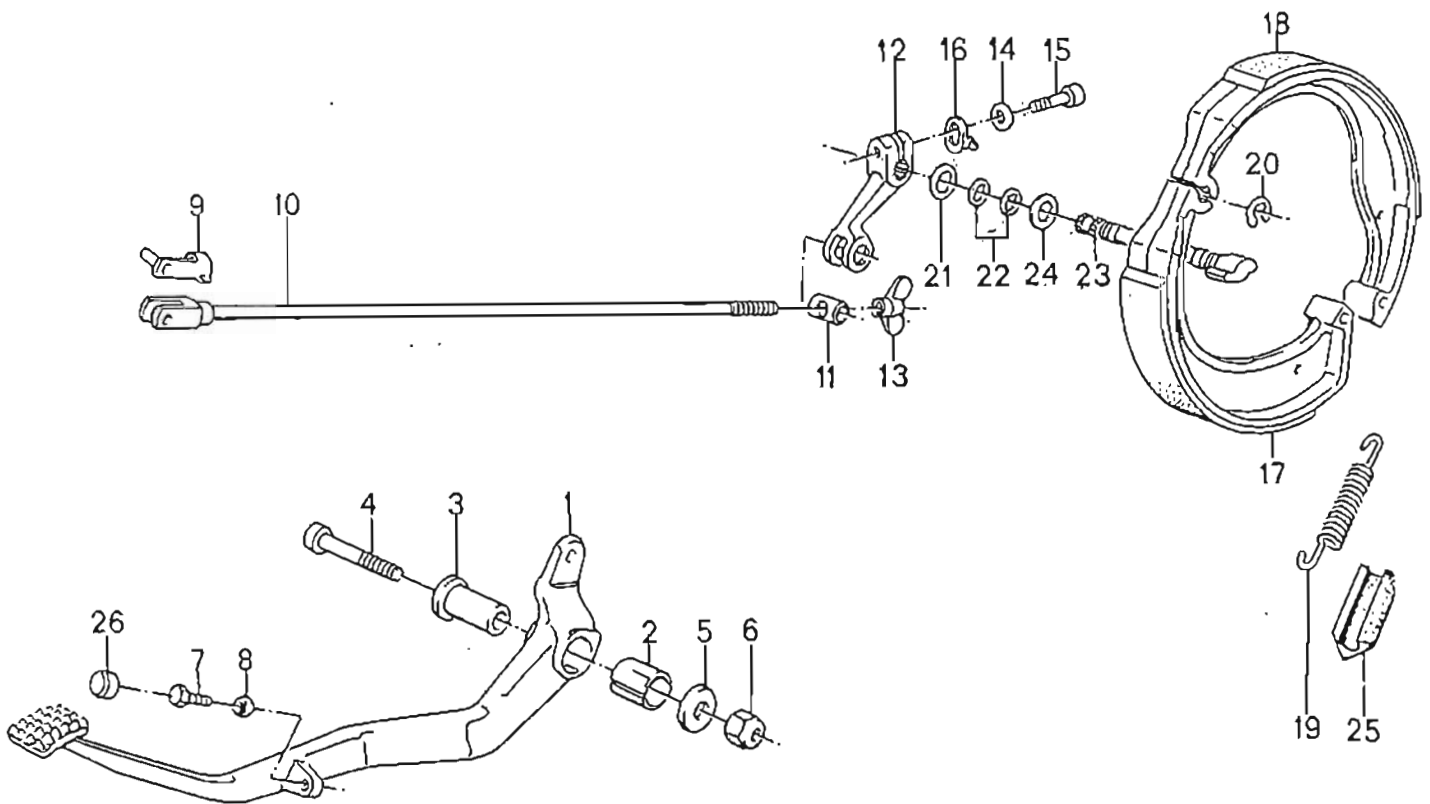

- 1 Footbrake pedal
- 2 Bushing
- 3 Bearing bushing
- 4 Machine screw
- 5 Washer
- 6 Hex nut
- 7 Hex screw
- 8 Hex nut
- 9 Pin
- 10 Pull rod
- 11 Pin
- 12 Wing nut
- 13 Brake backplate

- 14 Washer
- 15 Machine screw
- 16 Tab
- 17 Lower brake shoe
- 18 Upper brake shoe
- 19 Coil spring
- 20 Circlip
- 21 Sealing ring
- 22 O-ring
- 23 Sealing ring
- 24 Washer
- 25 Damper
- 26 Cap

Brake fluid – changing (front and rear)

Brake fluid must be renewed once a year.

Brake fluid is subject to extreme thermal load conditions (interaction) and natural ageing. Brake fluid is also hygroscopic, that is to say it absorbs moisture from the air. As a result, the boiling point of the brake fluid can fall to a dangerously low level.

Warning:

Do not allow any brake fluid to come into contact with the motorcycle's paintwork, or this will be severely damaged.



Only the procedure for bleeding the front brakes is described. The rear disc brake fluid is changed according to a similar procedure using the appropriate reservoir adapter.

Take off the lid of the brake fluid reservoir at the front and remove diaphragm.

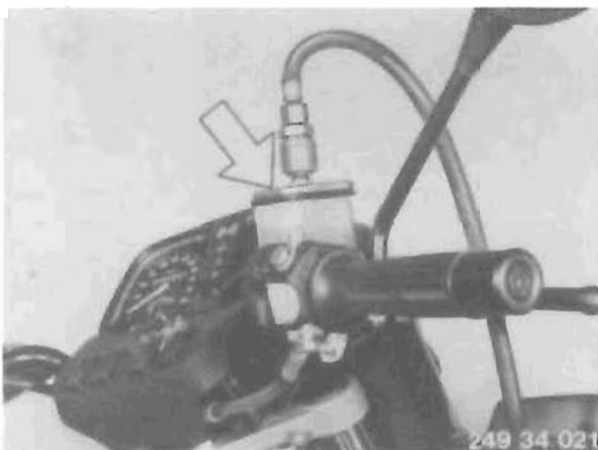

Connect up the brake fluid bleeding unit according to the manufacturer's instructions (unit shown here: **Joma 2 I**). Fit adapter to equaliser reservoir with retaining screws. Connect up hose from bleeding unit.

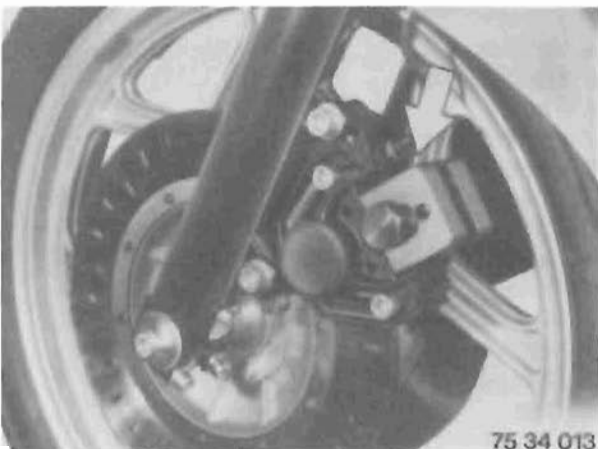

Remove brake pads (see page 34 – 12.0)

Insert piston setting-back device BMW 34 1 500 in brake caliper and push the piston back into the brake caliper with adjusting screw. (Only in this way can the brake fluid behind the piston be changed.)

Take out piston setting-back device again and insert spacer BMW 34 1 510 to hold the piston back in the brake caliper.

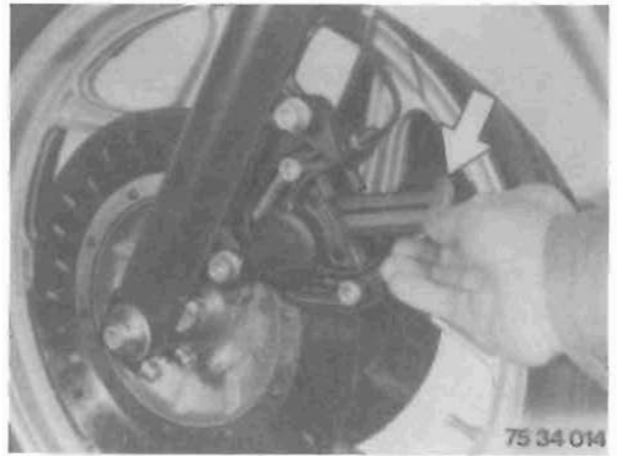

Set lever on bleeding unit to "Compressed air operation". Connect up pipe from overflow reservoir to brake caliper bleed screw (arrow), open bleed screw with open-ended wrench and allow all the brake fluid to drain out (carry out procedure at both brake callipers).

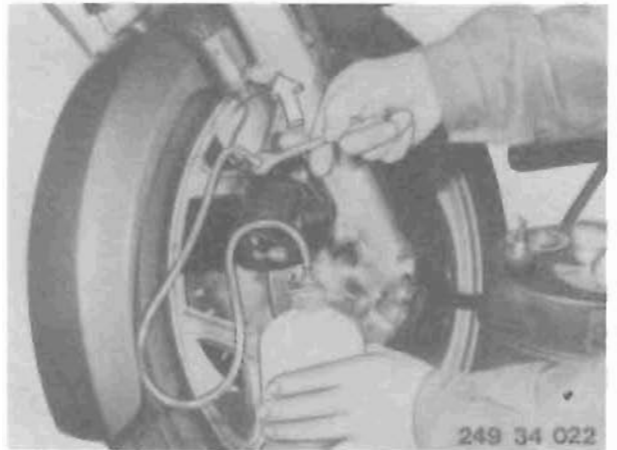

Set lever on bleeder unit to "Brake fluid operation". Leave the brake caliper bleed screw open until the brake fluid emerges free from bubbles (carry out procedure at both brake callipers).

Remove piston setting-back device and spacer again. Install brake pads (see page 34–12.0)

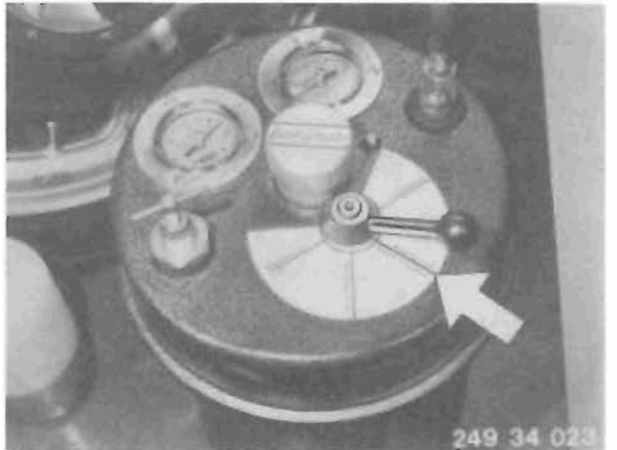

Set the lever on the bleeding unit to "Pressure release". Turn the handlebar once to left-hand lock and then to right-hand lock, applying the handbrake several times. The air will now escape from the brake master cylinder and pressure will build up. Remove the hose from the bleeding unit. Remove the adapter plate. Bring the brake fluid level up to "MAX". Fit cap with diaphragm and tighten the retaining screws.

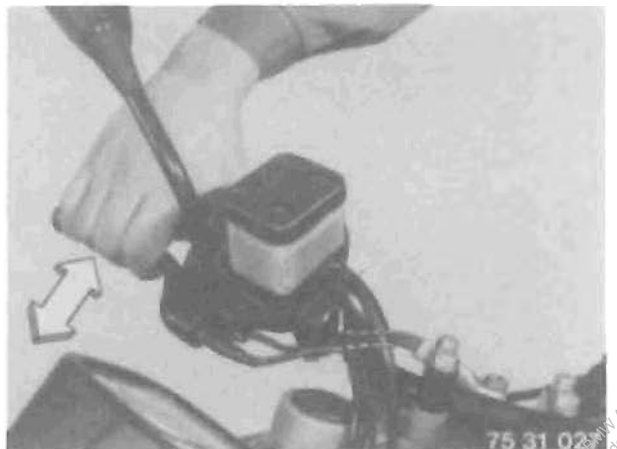

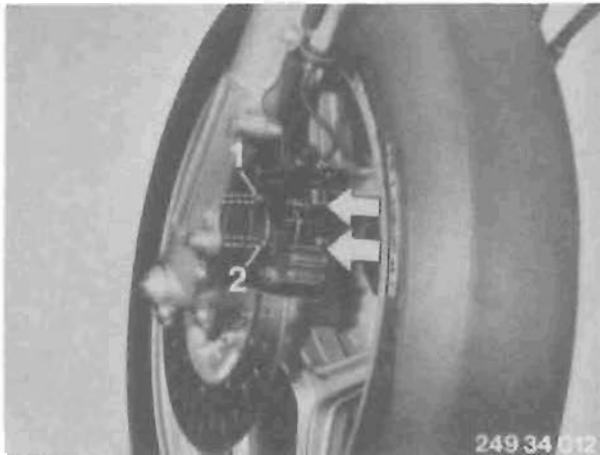

Front brake pads – removing and installing

Carefully lift off the protective cap with a screwdriver.
Using a suitable drift, force out retaining pins (1) and (2), working from the wheel side.
Take out the spring and pin.
Pull out the brake pads, using a wire hook if necessary.

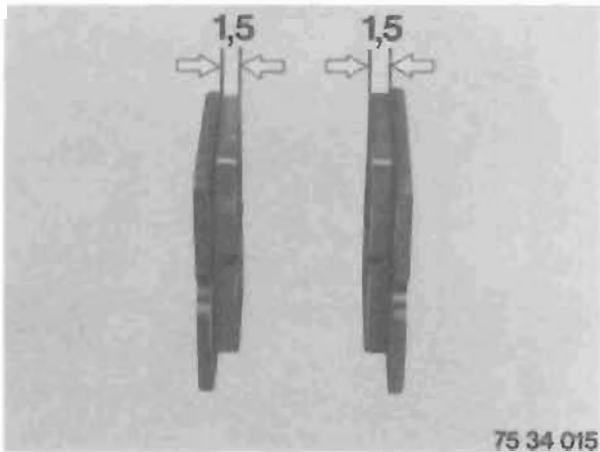

To prevent score marks on the brake disc, the brake pads must be renewed in good time if the minimum thickness is reached (see picture).

When installing:

Before the new brake pads are inserted, push back the piston into the brake cylinder.
Ensure that the spring and pin are properly located.
Drive in retaining pins with an arbor until they engage in position.

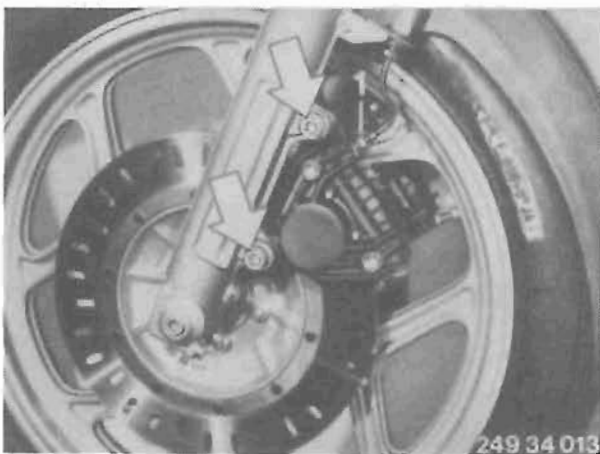

Front brake caliper – removing and installing

Drain the brake system.
Unscrew the brake pipe (1) on brake caliper.
Remove the retaining screws (arrow) and take off the brake caliper.

When assembling, work in the opposite sequence.
Fill and bleed the brake system as when changing brake fluid.

Tightening torques:

Retaining screw	$32 \pm 2 \text{ Nm}$
Brake pipe to brake caliper	$7 \pm 1 \text{ Nm}$
Bleed screw	$7 \pm 1 \text{ Nm}$

Rear brake pads – removing and installing

Lever off the protective cap with a screwdriver. Force out retaining pins (1) and (2) with a suitable drift, working from the exhaust-pipe end.
Take out spring and pin.
Pull out the brake pads, using a wire hook if necessary.

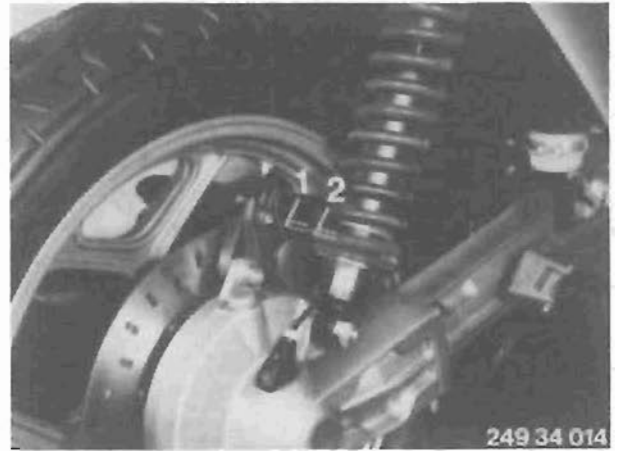

To avoid scoring the brake disc, the pads must be renewed when the minimum thickness is approached (see illust.).

When installing:

Before inserting the new pads, force the piston back into the brake cylinder.
Ensure that the spring and pin are correctly located.
Drive in retaining pins with arbor until they engage in position.

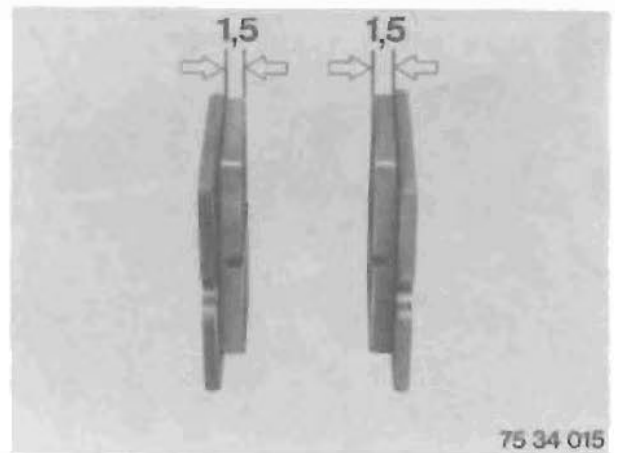

Rear brake caliper – removing and installing

Remove the rear wheel.
Unscrew the brake pipe from the caliper (arrow).
Tie up the brake pipe and stop up with a cloth, or drain with bleeder unit.



Remove the retaining screws (arrows) and take off the brake caliper.
Assemble following the same procedure but in the reverse order.

When installing:

When assembling, first screw the brake pipe into the caliper and then attach the caliper.
Bleed the brakes as when changing the brake fluid.

Tightening torques:

Retaining screw	$32 \pm 2 \text{ Nm}$
Brake pipe to brake caliper	$7 \pm 1 \text{ Nm}$
Bleed screw	$7 \pm 1 \text{ Nm}$

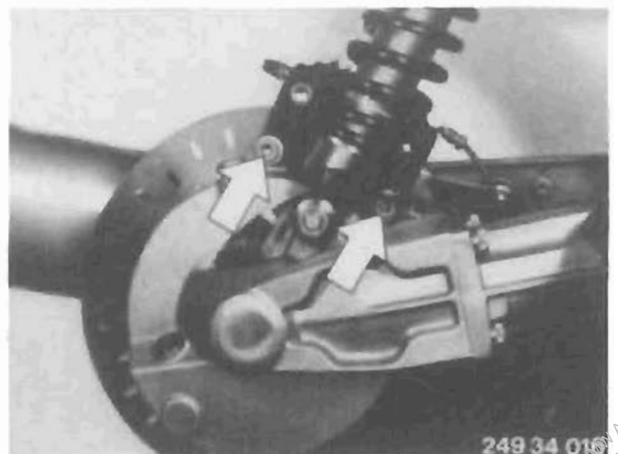

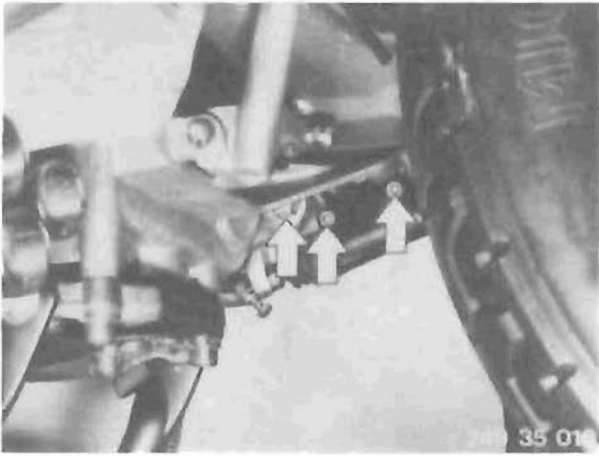

Rear brake master cylinder – removing and installing

Remove retaining screws on footbrake pedal and rear brake cylinder (arrow).

Note:

Grease the brake lever bearing before reassembling.

To provide a better picture, the silencer has been removed here.

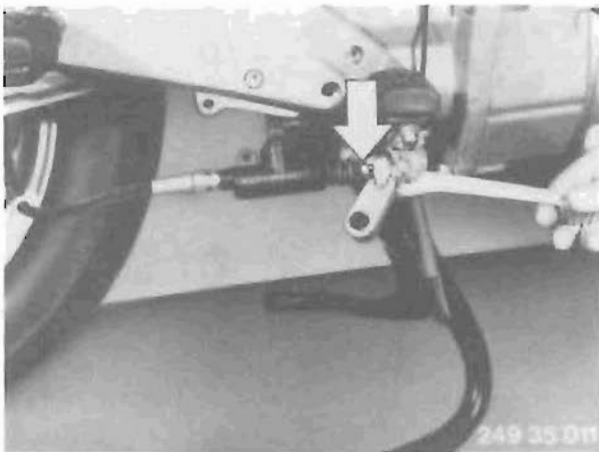

Remove locking nut (arrow) and unscrew footbrake lever from threaded rod on brake cylinder.

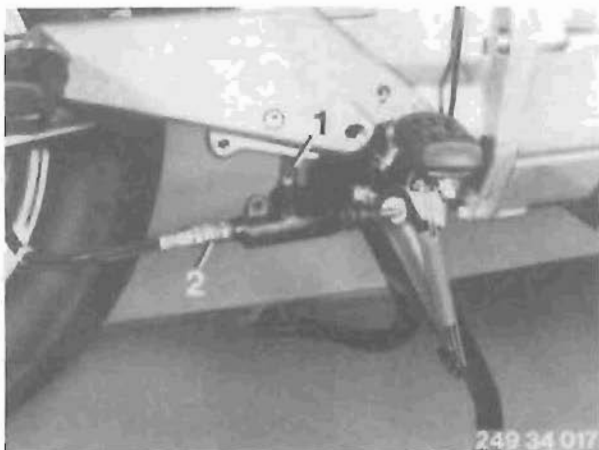

Detach brake fluid supply pipe (1) and brake hose (2) from the brake master cylinder.

Assemble following the same procedure but in the reverse order.

Tightening torques:

Brake hose to brake master cylinder	11 ± 1
Locking nut for footbrake lever	18 ± 2
Footbrake lever to footrest plate	25 ± 3
Brake master cylinder to footrest plate	6 ± 1

Brake shoes – removing

Warning:

As the brake shoe linings contain asbestos which constitutes a health hazard if inhaled in its dust form, the following safety precautions should be taken:

- Do not blow the brake drums clean; moisten brake dust and wipe off.
- Collect brake dust in a container with a close-fitting lid.
- Collect asbestos waste in sealed containers properly identified so as not to constitute any hazard for persons or the environment.

Slacken off wing nut for brake shoes on brake linkage.
Remove rear wheel (see page 36–07.0).
Lever off retainer (arrow) on brake mounting with a screwdriver.

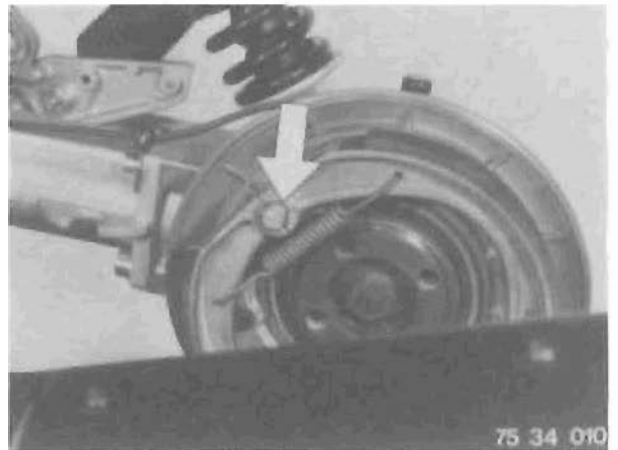

Grasp each brake shoe in one hand and pull off in the direction of the arrows.

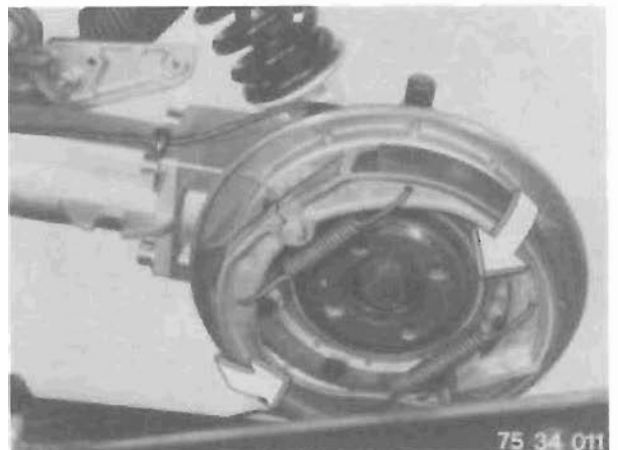

Brake shoes – installing

Clean dust off the rear wheel drive and rear brake drum (see above).

Fit springs on brake shoes.

Installed position:

Note that the springs should be on the outside.

Press both brake shoes simultaneously over the brake mounting and brake backplate.

Fit the retainer to the brake mounting.

Note:

Lightly grease the brake mounting and brake backplate with Shell Retinax A.

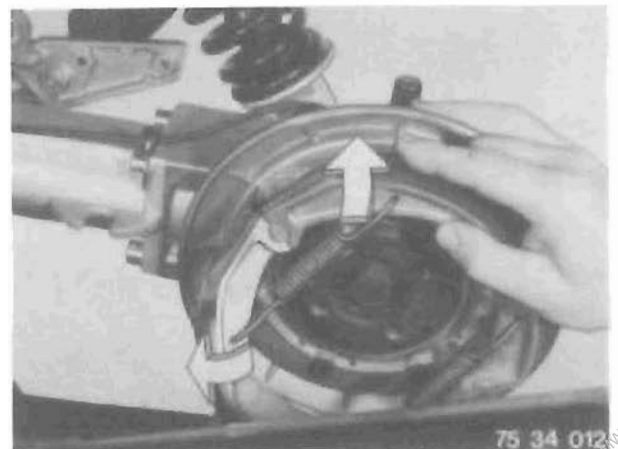

Install rear wheel.
The centre hub and hub contact surfaces must be clean and free from grease.

Warning:
Only use 55 mm long wheel studs (see stud head).

Tightening torque:
Wheel studs 105 ± 4 Nm

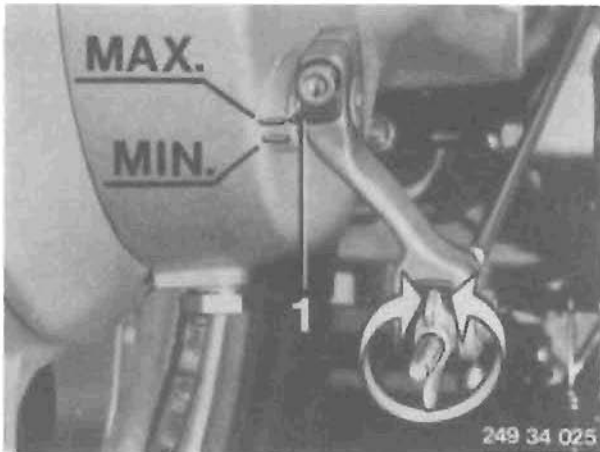

Rear drum brake – adjusting

Screw in pull rod wing nut until the rear wheel is just braked. Then slacken off the wing nut through 3-4 revolutions (equivalent to app. 25 mm footbrake pedal play).
Set pointer (1) to "MAX" when the brake shoes are making contact.

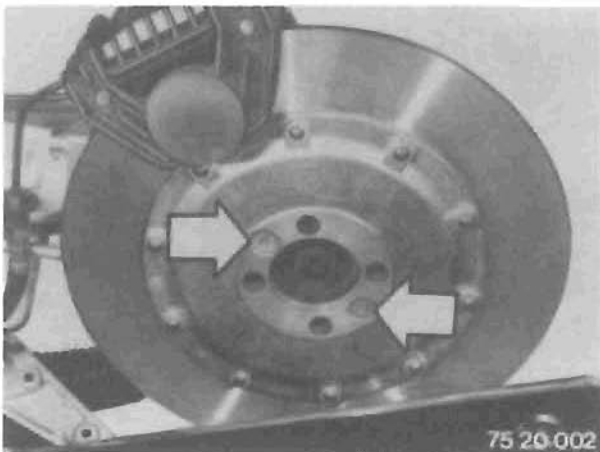

Rear brake disc – removing and installing

Remove rear wheel (see page 36–07.0).
Remove retaining screws (arrows) and take off brake disc.
Assemble following the same procedure but in the reverse order.

Tightening torques:
Brake disc on rear wheel drive 21 ± 2 Nm
Rear wheel studs 105 ± 4 Nm

Front brake discs – removing and installing

Raise the motorcycle with BMW hoist 00 1 510 until the front wheel is free.

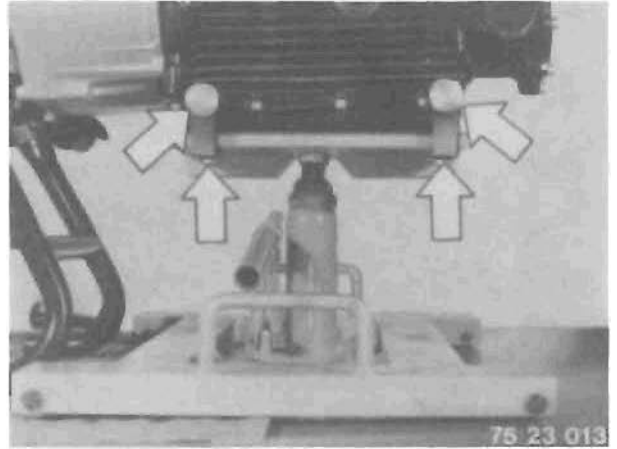

Remove retaining screws (arrows), pull brake caliper off brake disc and allow to hang freely.

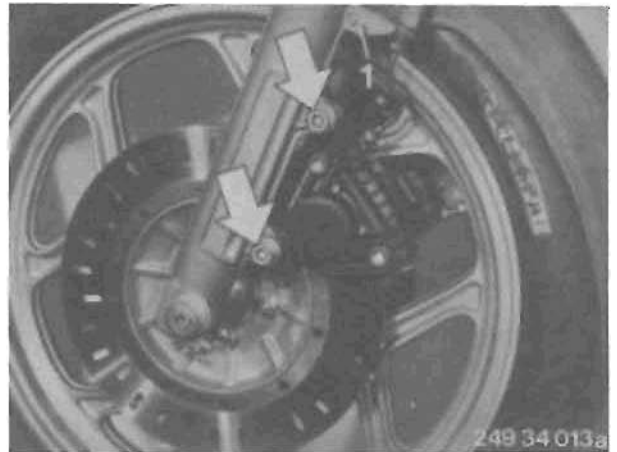

Slacken off clamping screws (arrows) on quick-release axle on either side.
Remove retaining screw (1) for quick-release axle.
Pull out quick-release axle, noting spacer (2).
Pull front wheel forward to remove.

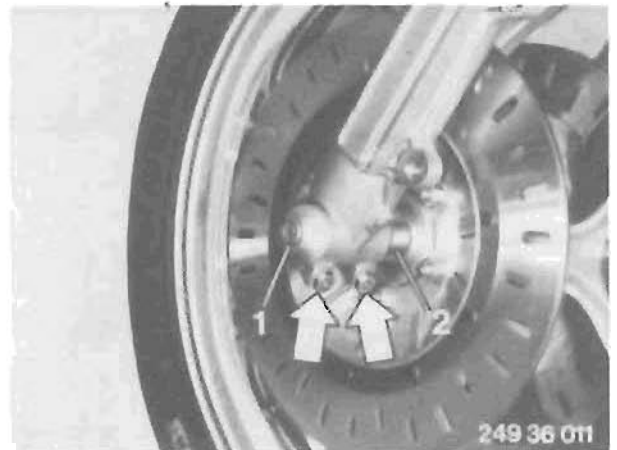

Remove four retaining screws for brake discs; take off brake discs.
Assemble following the same procedure but in the reverse order.

Tightening torques:

Brake disc to front wheel	29 ± 3 Nm
Retaining screw for quick-release axle	33 ± 4 Nm
Clamping screw for quick-release axle	14 ± 2 Nm
Brake caliper to sliding tube	32 ± 2 Nm

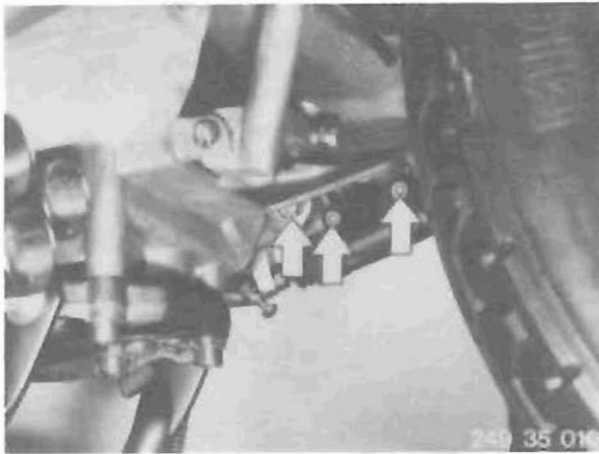

Footbrake pedal – removing and installing

Models with rear disc brake

Remove retaining screws from footbrake pedal and remove rear brake cylinder (arrows).

Note:

Grease the brake pedal pivot before assembling.

To provide a better picture, the engine has been removed here.



Take off the locking nut (arrow) and unscrew the brake pedal from the threaded rod on the brake cylinder.

Assemble following the same procedure but in the reverse order.

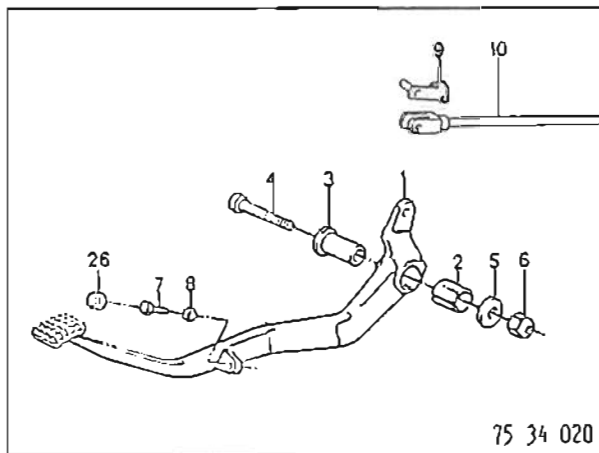

Models with rear drum brake

Pull out pin with retaining clip (9). Remove retaining screw (4) for footbrake pedal (1) and take off footbrake pedal.

Assemble following the same procedure but in the reverse order.

Footbrake light switch – removing and installing

Remove both lower cable connectors.
Disconnect plug for brake light switch (1).

Cable coding:

Yellow } ⇒ { Green/grey
Yellow } ⇒ { Green/black



Remove retaining screws (1, 2, 3) for right-hand footrest plate.

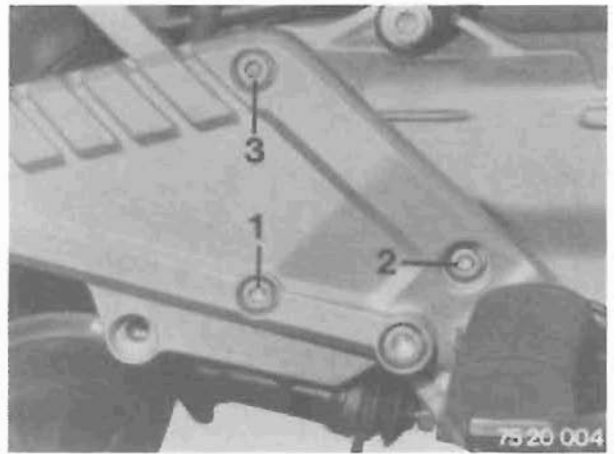

Microswitch (left-hand illustration):
Remove retaining screw (arrow) and take out switch.
Valvar switch (right-hand illustration):
Unscrew switch with 11 mm open-ended wrench.

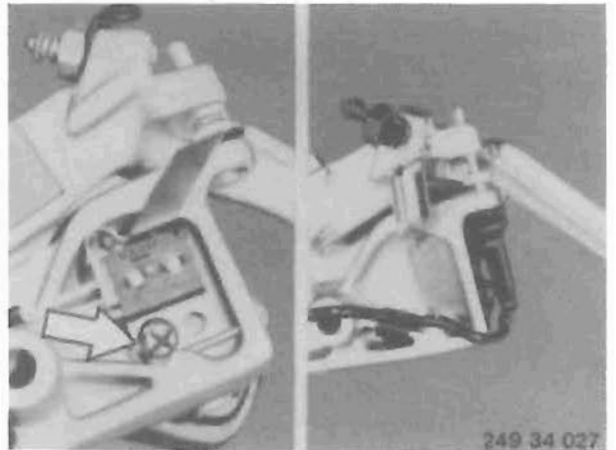

Assemble following the same procedure but in the reverse order.

When installing microswitch:

The switch mounting plate must be in contact with the cast rib of the footrest plate (arrow). Actuator lug must not be in contact with the footrest plate.

When the footbrake lever is actuated, the switch must be heard to click.

Apply a coating of Loctite 242 to the retaining screw and tighten the screw slightly (max. 5 Nm).

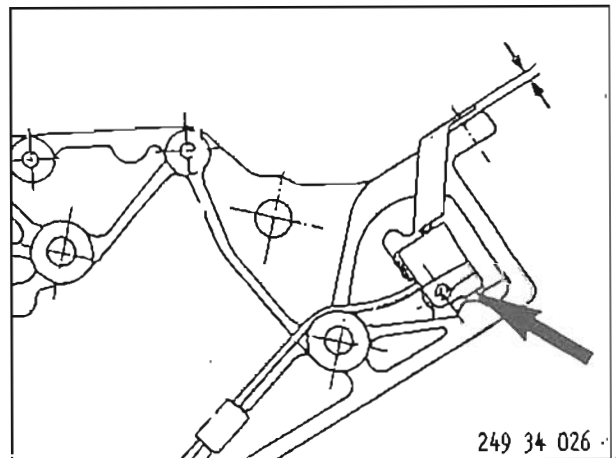

Handbrake light switch – removing and installing

Remove fuel tank (see page 16–01.0).

Disconnect plug for handbrake light switch on right below fuel tank.

Cable coding:

Yellow } = { Green/black
Yellow } { Grey/red

Detach cable connector on handlebar and pull up cable to remove.

Remove switch from handlebar fitting with 11 mm open-ended wrench.

Assemble following the same procedure but in the reverse order.

36





Wheels and tyres

36 Wheels and tyres

Specifications	Page	36-03.0
Tightening torques		36-04.0
Diagrams		36-05.0
Front wheel – removing and installing		36-06.0
Front wheel bearing – removing and installing		36-06.0
Rear wheel – removing and installing		36-07.0

Wheels and tyres

Specifications

Model		K 75	K 75 c	K 75 s	K 100	K 100 RS	K 100 RT	K 100 LT																																																																																	
Rim type		Cast light-alloy																																																																																							
Rim size	front	MTH 2.50×18 E																																																																																							
Rim size	rear	MTH 2.75×13 E		MTH 2.75×17 E																																																																																					
Radial runout, max.	mm	0.5 measured at rim flange, without tyre																																																																																							
max.	mm	0.5																																																																																							
Tyre size	front	100/90 H 18 TUBELESS		100/90 V 18, or 100/90 VR 18* on 																																																																																					
Tyre size	rear	120/90 H 18 TUBELESS		130/90 V 17, or 140/80 VR 17* on 																																																																																					
Tyre pressure (tyres cold)	bar	<table border="1" style="width:100%; border-collapse: collapse;"> <thead> <tr> <th rowspan="3">Speed</th> <th colspan="4">H tyres</th> <th colspan="4">V tyres</th> <th colspan="4">VR tyres </th> </tr> <tr> <th colspan="2">Solo</th> <th colspan="2">With pillion</th> <th colspan="2">Solo</th> <th colspan="2">With pillion</th> <th colspan="2">Solo</th> <th colspan="2">With pillion</th> </tr> <tr> <th>Front</th> <th>Rear</th> <th>Front</th> <th>Rear</th> <th>Front</th> <th>Rear</th> <th>Front</th> <th>Rear</th> <th>Front</th> <th>Rear</th> <th>Front</th> <th>Rear</th> </tr> </thead> <tbody> <tr> <td>no limit</td> <td>2.0</td> <td>2.50</td> <td>2.30</td> <td>2.90</td> <td>2.25</td> <td>2.50</td> <td>—</td> <td>—</td> <td>2.55</td> <td>2.80</td> <td>—</td> <td>—</td> </tr> <tr> <td>up to 180 km/h</td> <td>—</td> <td>—</td> <td>—</td> <td>—</td> <td>—</td> <td>—</td> <td>2.25</td> <td>2.70</td> <td>—</td> <td>—</td> <td>2.55</td> <td>3.00</td> </tr> <tr> <td>over 180 km/h</td> <td>—</td> <td>—</td> <td>—</td> <td>—</td> <td>—</td> <td>—</td> <td>2.70</td> <td>2.90</td> <td>—</td> <td>—</td> <td>3.00</td> <td>3.20</td> </tr> </tbody> </table>												Speed	H tyres				V tyres				VR tyres 				Solo		With pillion		Solo		With pillion		Solo		With pillion		Front	Rear	Front	Rear	Front	Rear	Front	Rear	Front	Rear	Front	Rear	no limit	2.0	2.50	2.30	2.90	2.25	2.50	—	—	2.55	2.80	—	—	up to 180 km/h	—	—	—	—	—	—	2.25	2.70	—	—	2.55	3.00	over 180 km/h	—	—	—	—	—	—	2.70	2.90	—	—	3.00	3.20
Speed	H tyres				V tyres				VR tyres 																																																																																
	Solo		With pillion		Solo		With pillion		Solo		With pillion																																																																														
	Front	Rear	Front	Rear	Front	Rear	Front	Rear	Front	Rear	Front	Rear																																																																													
no limit	2.0	2.50	2.30	2.90	2.25	2.50	—	—	2.55	2.80	—	—																																																																													
up to 180 km/h	—	—	—	—	—	—	2.25	2.70	—	—	2.55	3.00																																																																													
over 180 km/h	—	—	—	—	—	—	2.70	2.90	—	—	3.00	3.20																																																																													
Wheel bearing lubrication		Brand anti-friction bearing grease Operating temperature range –30° ... +140°C, Drip point 150° ... 230°C High corrosion protective properties Highly resistant to water/oxidation, e.g. Shell Retinax A																																																																																							

* Only fit VR tyres in pairs

Wheels and tyres**Tightening torques**

Connection	Nm
Brake disc to front wheel	29 ± 3
Brake caliper to sliding tube	32 ± 2
Clamping screw on quick-release axle	14 ± 2
Retaining screw on quick-release axle	33 ± 4
Wheel stud (rear)	105 ± 4

Front wheel bearings

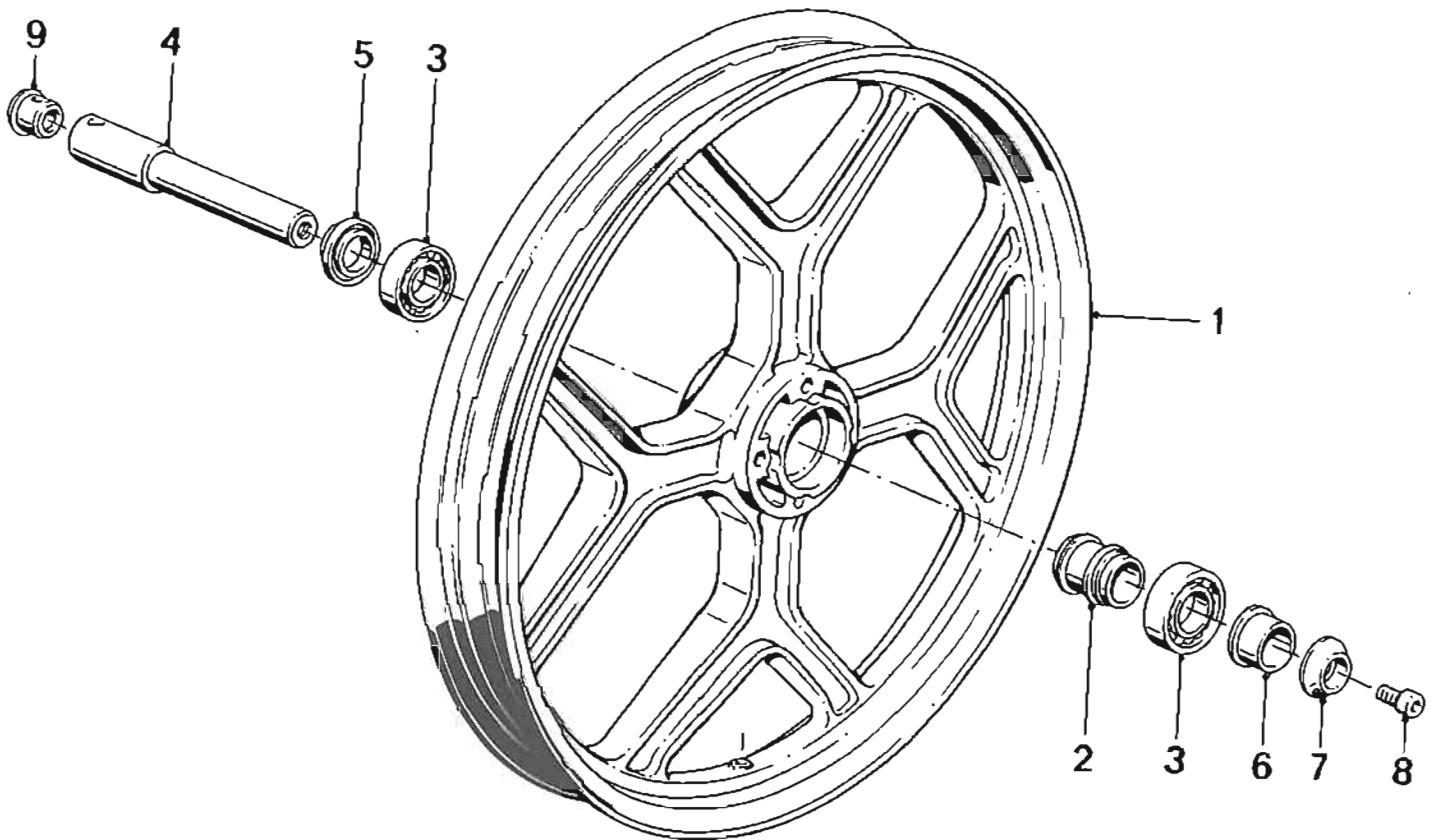

- 1 Cast wheel (front)
- 2 Spacer sleeve
- 3 Deep-groove ball bearing
- 4 Quick-release axle
- 5 Bushing
- 6 Bushing
- 7 Spacer
- 8 Machine screw
- 9 Cap

Front wheel – removing and installing

Remove retaining screws for brake caliper on sliding tubes on both sides; pull brake calipers off brake discs and allow to hang freely.

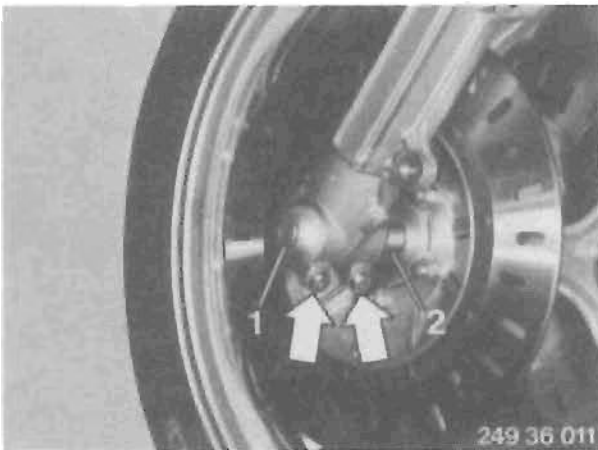

Slacken off the quick-release axle clamping screws (arrows) on left and right.

Remove retaining screw (1) for quick-release axle.

Raise the motorcycle with hoist BMW 00 1 510 until the front wheel is free to turn.

Pull out the quick-release axle, noting spacer (2). Pull out front wheel to the front.

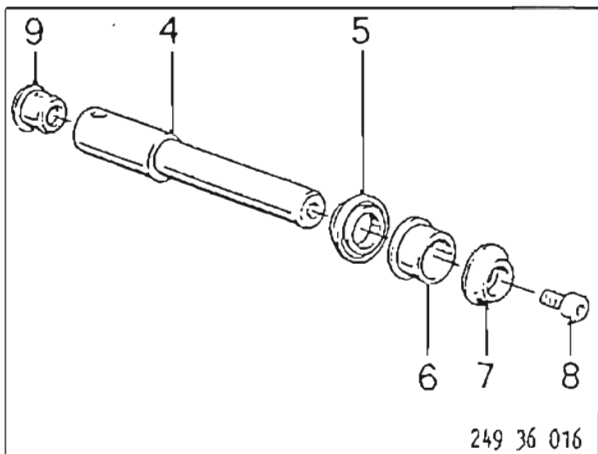

Assemble following the same procedure but in the reverse order.

When installing:

Insert spacer bushings (5) and (6) in the appropriate place.

5 right-hand bushing (narrow)

6 left-hand bushing (wide)

Warning:

Ensure that the dust cap is firmly on the valve.

Tightening torque:

Brake caliper to sliding tube 32 ± 2 Nm

Retaining screw for quick-release axle 33 ± 4 Nm

Clamping screw for quick-release axle 14 ± 2 Nm

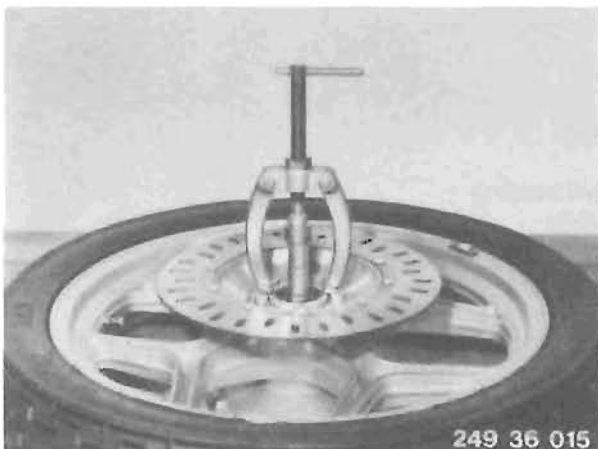

Front wheel bearings – removing and installing

Pull out the deep-groove ball bearing with bearing puller BMW 00 8 570 and insert 21/4, BMW 00 8 573.

When installing:

Remove brake discs.

Heat up hub to app. 100°C and press in new bearing.

Secure brake discs.

Tightening torque:

Brake disc to front wheel

29 Nm

Rear wheel – removing and installing

Remove retaining screws (arrows) on licence plate holder, slacken off nuts at rear and take off licence plate holder.

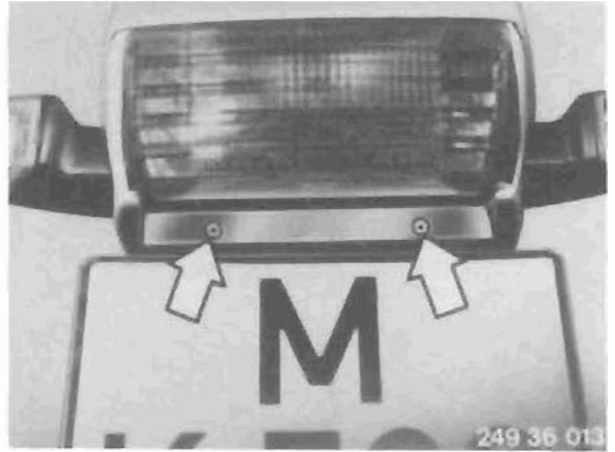

Remove rear-wheel retaining screws and take out rear wheel.

Models with rear disc brake
Note spacer.



Assemble following the same procedure but in the reverse order.

When installing:

Contact surfaces between rear wheel and rear wheel drive must be free from grease.

Models with rear drum brake

Wheel studs 55 mm long (marked on stud head).

Models with rear disc brake

Wheel studs 60 mm long (stud head marked or unmarked).

Warning

Ensure that the dust cap is properly on the valve.

Tightening torque:

Retaining screw

$105 \pm 4 \text{ Nm}$

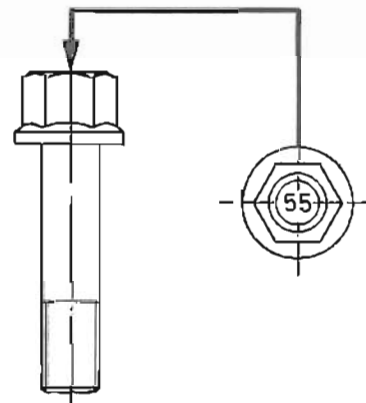

75 36 015

46

Frame, fairing

46 Frame, fairing

Technical data	Page	46-03.0
Tightening torques		46-05.0
Diagrams		46-06.0
K 75 headlight fairing – removing and installing		46-13.0
K 75 c cockpit fairing – removing and installing		46-15.0
K 100 headlight fairing – removing and installing		46-17.0
K 75, K 75 c radiator trim – removing and installing		46-19.0
K 100 radiator trim – removing and installing		46-20.0
K 75 s fairing – removing and installing		46-21.0
Windshield – removing and installing		46-21.0
Radiator trim – removing and installing		46-21.0
Side fairings – removing and installing		46-22.0
Centre fairing – removing and installing		46-24.0
Instrument cluster – removing and installing		46-25.0
Fairing mounting – removing and installing		46-26.0
Engine spoiler  removing and installing		46-28.0
K 100 RS fairing removing and installing		46-31.0
Knee pads – removing and installing		46-31.0
Side fairings – removing and installing		46-32.0
Radiator trim – removing and installing		46-33.0
Mirror with integral turn indicator – removing and installing		46-34.0
Inner fairing – removing and installing		46-34.0
Upper fairing – removing and installing		46-36.0
Fairing mounting – removing and installing		46-37.0
K 100 RT, LT fairing – removing and installing		46-39.0
Storage compartment and knee pads – removing and installing		46-39.0
Lower fairing – removing and installing		46-40.0
Radiator trim – removing and installing		46-42.0
Windshield and inner fairing – removing and installing		46-42.0
Upper fairing – removing and installing		46-44.0
Fairing mounting – removing and installing		46-45.0
Storage compartment flap – removing and installing		46-46.0
Front mudguard – removing and installing		46-47.0
Frame – removing		46-48.0
Handlebar and fittings – removing		46-48.0
Telescopic fork with front wheel – removing		46-51.0
Radiator – removing		46-53.0
Dalseat – removing		46-54.0
Rear section with rear mudguard – removing		46-55.0
Fuel injection control unit – removing		46-56.0
Electrical connections – disconnecting		46-57.0
Frame – disconnecting from driveline		46-58.0
Steering lock – removing		46-58.0
Ignition control unit – removing		46-59.0
Frame wiring harness – removing (frame removed)		46-59.0
Dalseat lock – removing		46-59.0
Grab handle – removing		46-60.0
Bearing shells for steering head bearing – removing		46-60.0
Rubber bearing on frame – removing		46-60.0

Frame installing	Page 46–61.0
Fluidbloc  installing	46–61.0
Bearing shells for steering head bearing – installing	46–61.0
K 100 RS, RT, LT front silentblocs – pressing in	46–61.0
Dalseat lock, steering lock – installing	46–62.0
Lift handle – installing	46–62.0
Frame wiring harness – installing	46–62.0
Frame – fitting to driveline	46–67.0
Telescopic fork – installing	46–68.0
Handlebar – installing	46–69.0
Steering head bearing – adjusting	46–69.0
Cables – adjusting	46–70.0
Distributor pipe – installing	46–71.0
Divider – installing	46–72.0
Rear mudguard – installing	46–72.0
Rear section – installing	46–73.0
Radiator – installing	46–74.0
Coolant – topping up	46–74.0
Dalseat – installing	46–75.0
Centre stand – removing and installing	46–76.0
Lift handle – removing and installing	46–77.0
Wheel offset – measuring	46–78.0
Frame – checking	46–80.0

Frame

Technical data

Model	K 75	K 75 c	K 75 s	K 100	K 100 RS	K 100 RT	K 100 LT
Frame							
Location of manufacturer's plate	On frame tube strut, at rear on right						
Location of frame number							
Motorcycle dimensions and weight							
Maximum width (across mirrors) mm	850		830	930	820	920	
Seat height, off-load mm	810						
Overall length mm	2220						
Wheelbase, off-load mm	1516						
Wheel offset mm	max. 5						
Unladen weight kg	227		229	239	253	263	283
Gross weight limit kg	450			480			

Frame, fairing sections**Tightening torques**

Connection	Nm
Frame to engine, intermediate flange, gearbox	45 – 6
Pivot block to gearbox	41 ± 5
Centre stand to pivot block	41 ± 5
Side stand to pivot block	41 ± 5
Footrest plate to gearbox	15 ± 2
Pivot block to footrest plate	29 ± 3
Fairing holder to engine	9 ± 1
Fairing rear panel to K 75, c, K 100 fork bridge	9 ± 1

K 75 s fairing sections

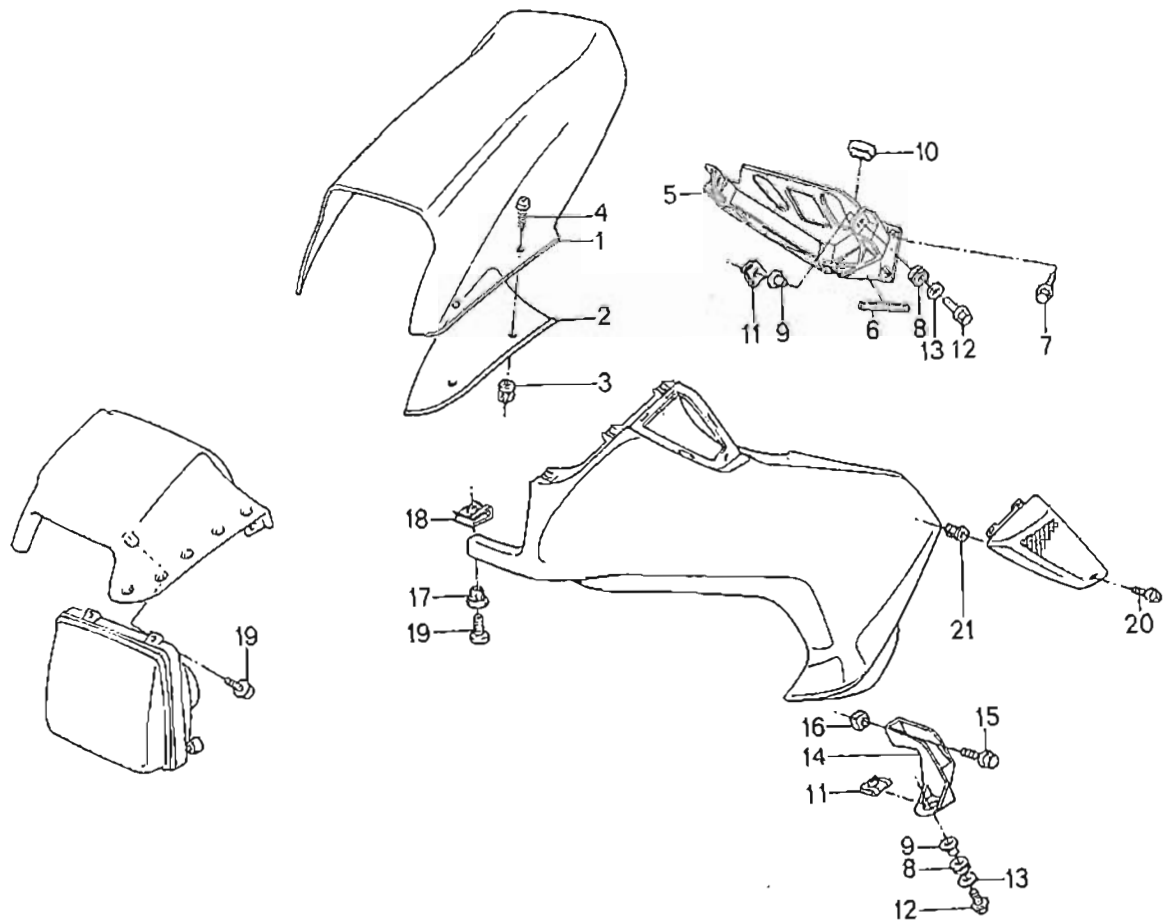

- | | |
|-----------------------|--------------------|
| 1 Windshield | 12 Retaining screw |
| 2 Abrasion protector | 13 Washer |
| 3 Spreader nut | 14 Fairing holder |
| 4 Retaining screw | 15 Retaining screw |
| 5 Fairing holder | 16 Square nut |
| 6 Edge protector | 17 Sleeve |
| 7 Taper screw | 18 Sheet metal nut |
| 8 Rubber bushing | 19 Retaining screw |
| 9 Bushing | 20 Retaining screw |
| 10 Abrasion protector | 21 Spreader nut |
| 11 Sheet metal nut | |

K 75 s fairing sections

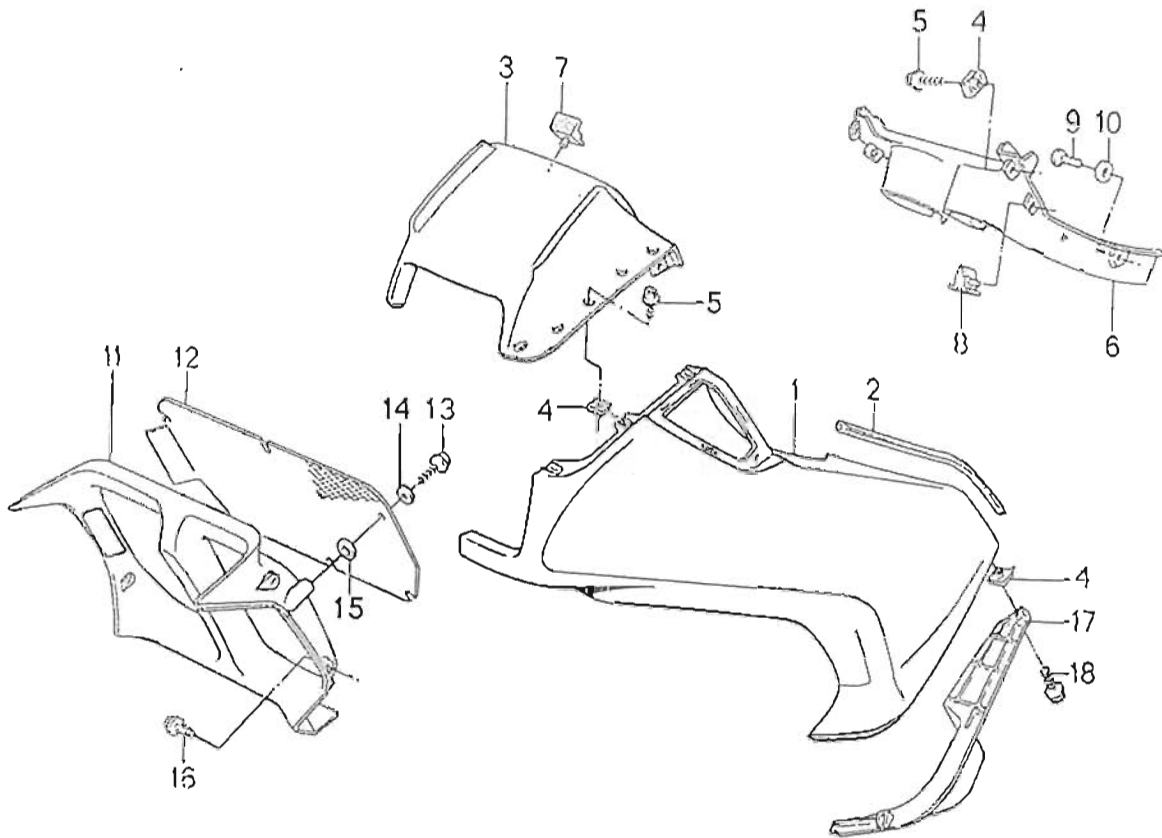

- | | | | |
|---|------------------------|----|-----------------|
| 1 | Fairing side section | 10 | Shim |
| 2 | Fillet | 11 | Radiator trim |
| 3 | Centre fairing section | 12 | Radiator grille |
| 4 | Sheet metal nut | 13 | Retaining screw |
| 5 | Retaining screw | 14 | Washer |
| 6 | Inner cover | 15 | Washer |
| 7 | Buffer | 16 | Retaining screw |
| 8 | Buffer | 17 | Cover |
| 9 | Retaining screw | 18 | Retaining screw |

Rear section

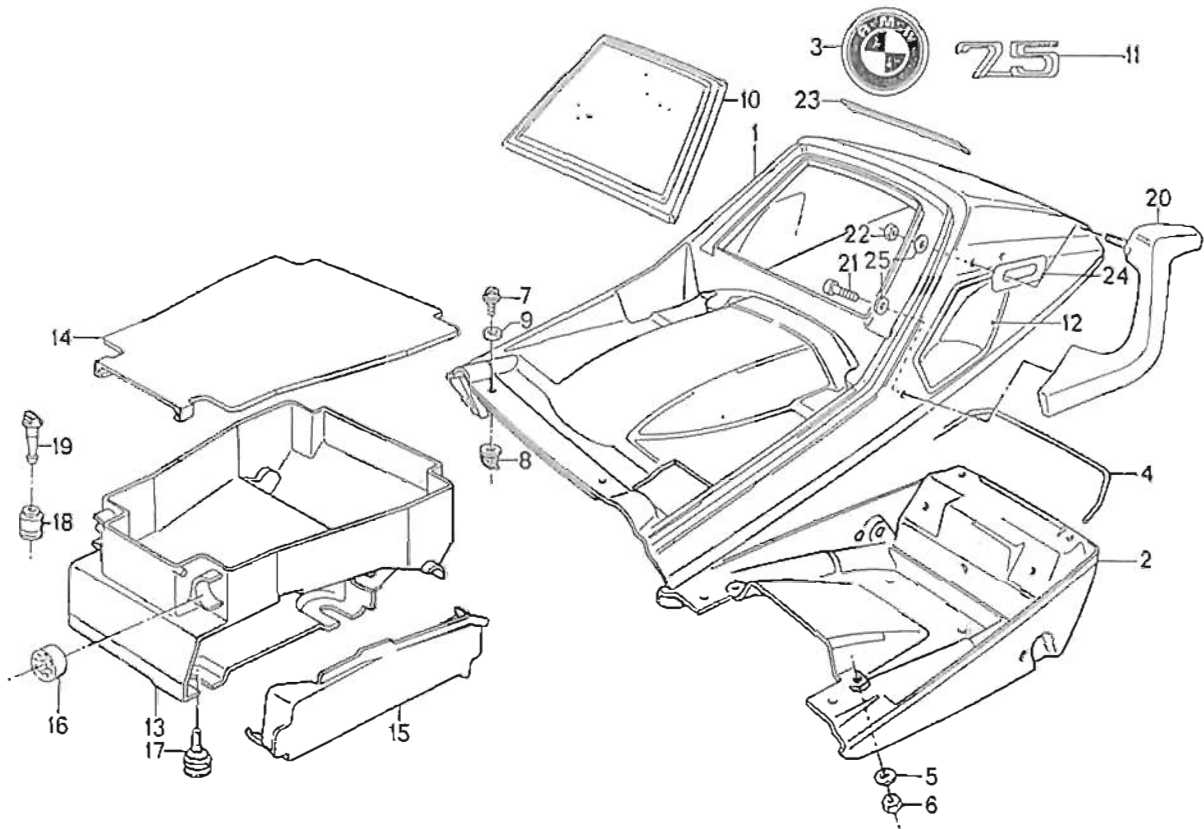

- | | |
|----------------------|------------------------|
| 1 Upper rear section | 14 Cover |
| 2 Lower rear section | 15 Side cover |
| 3 Emblem | 16 Rubber stopper |
| 4 Fillet | 17 Buffer |
| 5 Washer | 18 Buffer |
| 6 Nut | 19 Pin |
| 7 Retaining screw | 20 Grab handle |
| 8 Spreader nut | 21 Retaining screw |
| 9 Washer | 22 Nut |
| 10 Cover | 23 Seal |
| 11 Inscription | 24 Abrasion protection |
| 12 Grab recess | 25 Washer |
| 13 Toolbox | |

Footrest plate

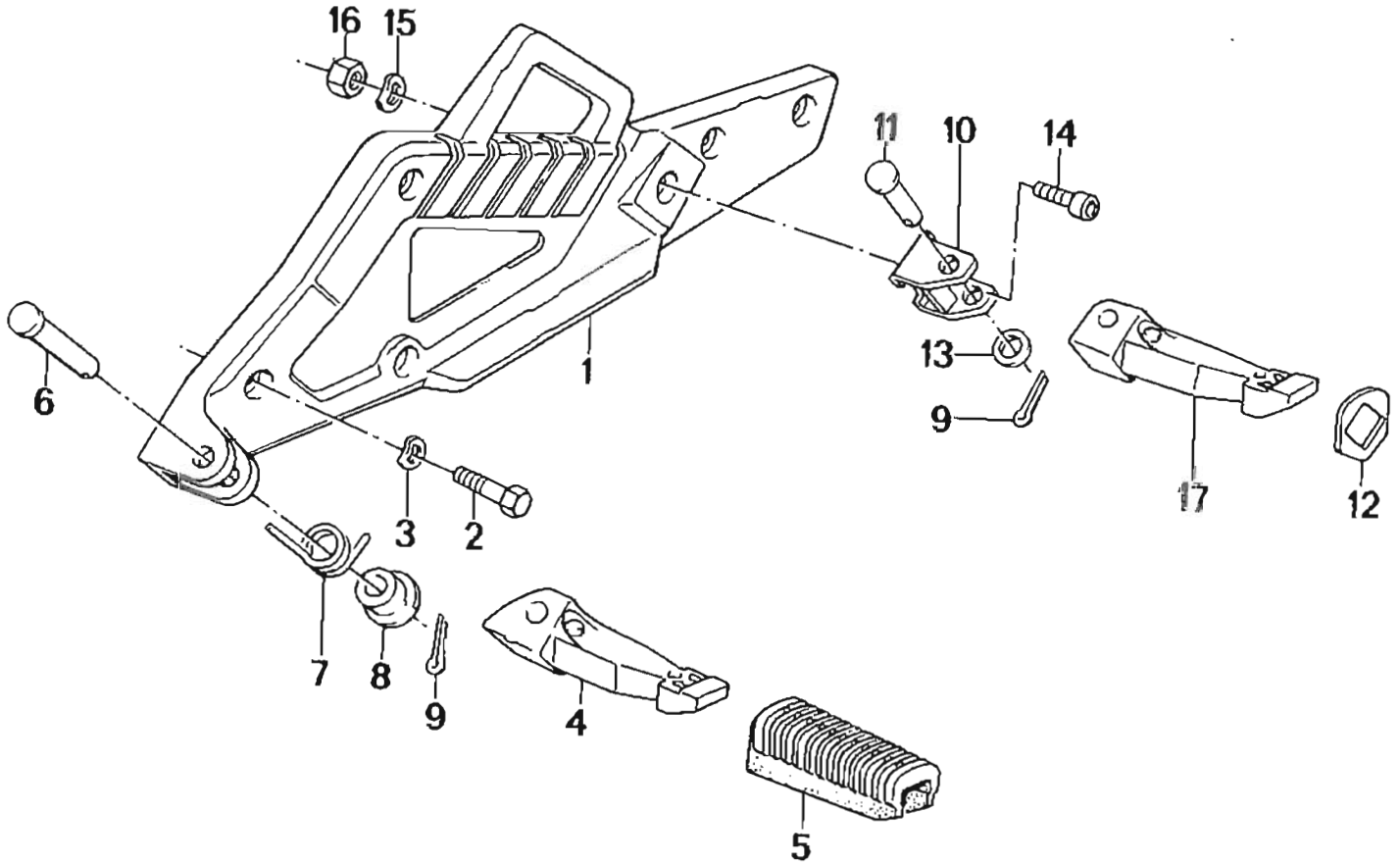

- 1 Left footrest plate
- 2 Retaining screw
- 3 Washer
- 4 Front left footrest
- 5 Footrest rubber
- 6 Pin
- 7 Torsion spring
- 8 Sleeve
- 9 Splint

- 10 Pivot block
- 11 Pin
- 12 Support plate
- 13 Washer
- 14 Retaining screw
- 15 Washer
- 16 Nut
- 17 Rear left footrest

Centre stand and side stand

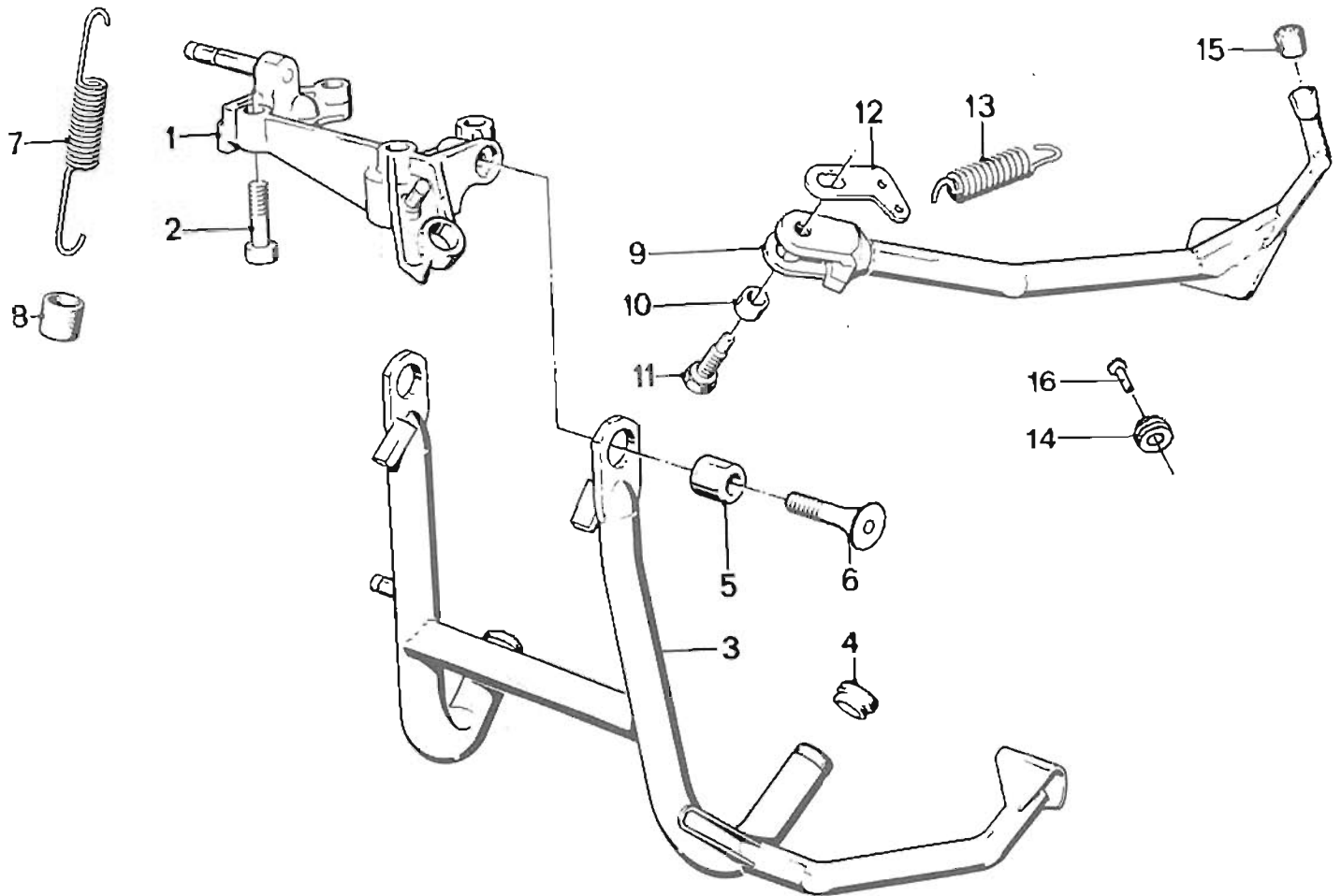

- 1 Pivot block
- 2 Machine screw
- 3 Centre stand
- 4 Cap
- 5 Sleeve
- 6 Machine screw
- 7 Spring
- 8 Rubber bushing

- 9 Side stand
- 10 Bushing
- 11 Retaining screw
- 12 Plate
- 13 Spring
- 14 Buffer
- 15 Cap
- 16 Blind rivet
- 17 Snapping

Front mudguard

Models with fork stabiliser

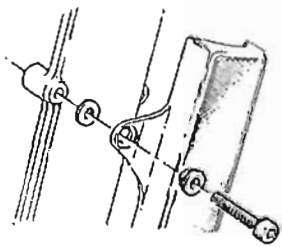
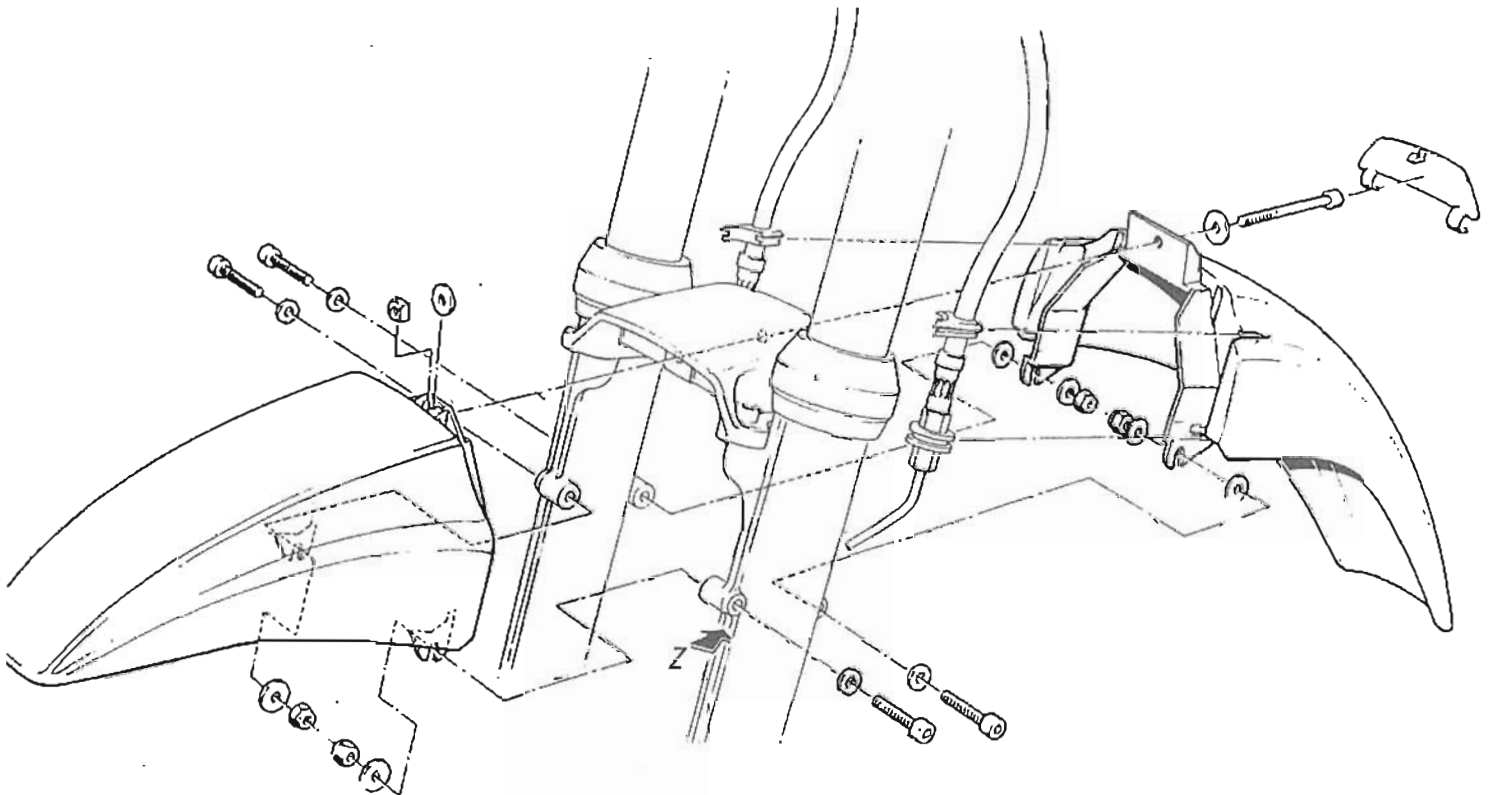

Ansicht Z

K 75 headlight fairing – removing and installing

Remove retaining screw (arrow) and take headlight out of housing.

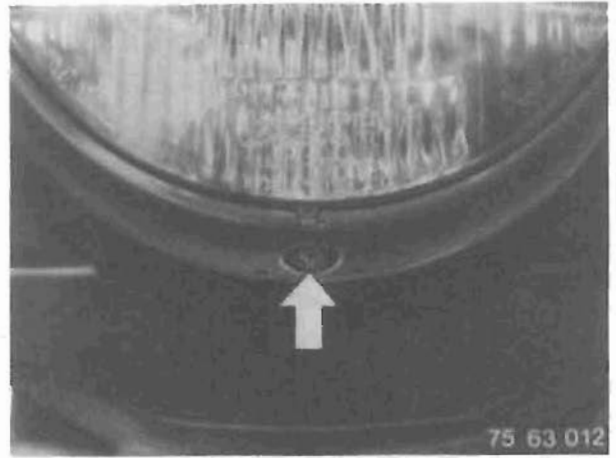

Pull plug connections off the headlight and take off the headlight.

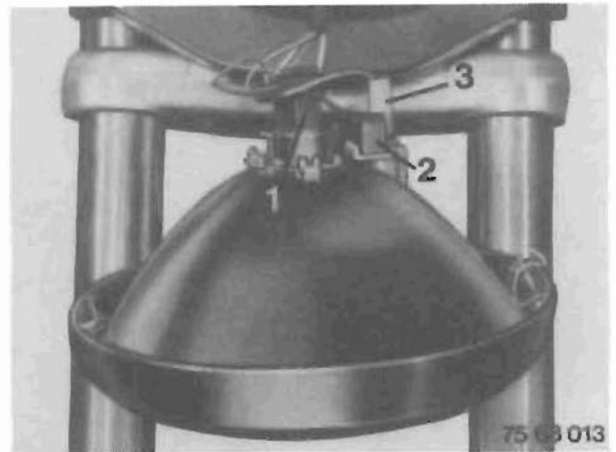

Remove retaining screws on left and right (arrows) for headlight housing and take off the housing. Remove headlight fairing retaining screws (1).



Remove retaining screws in the rear panel on right (arrow) and left, and take off the headlight fairing.

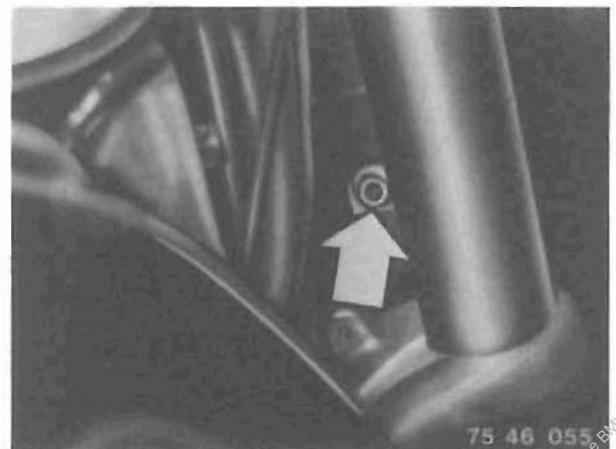

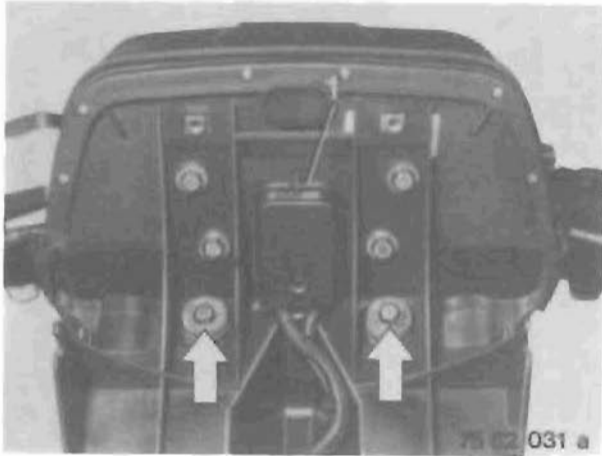

Take off cover cap (1) and pull out multi-pin plug.
Remove retaining screws for rear panel at top and base of the fork bridge.
Take off the rear panel together with instrument cluster.
Install following the same procedure but in the reverse order.

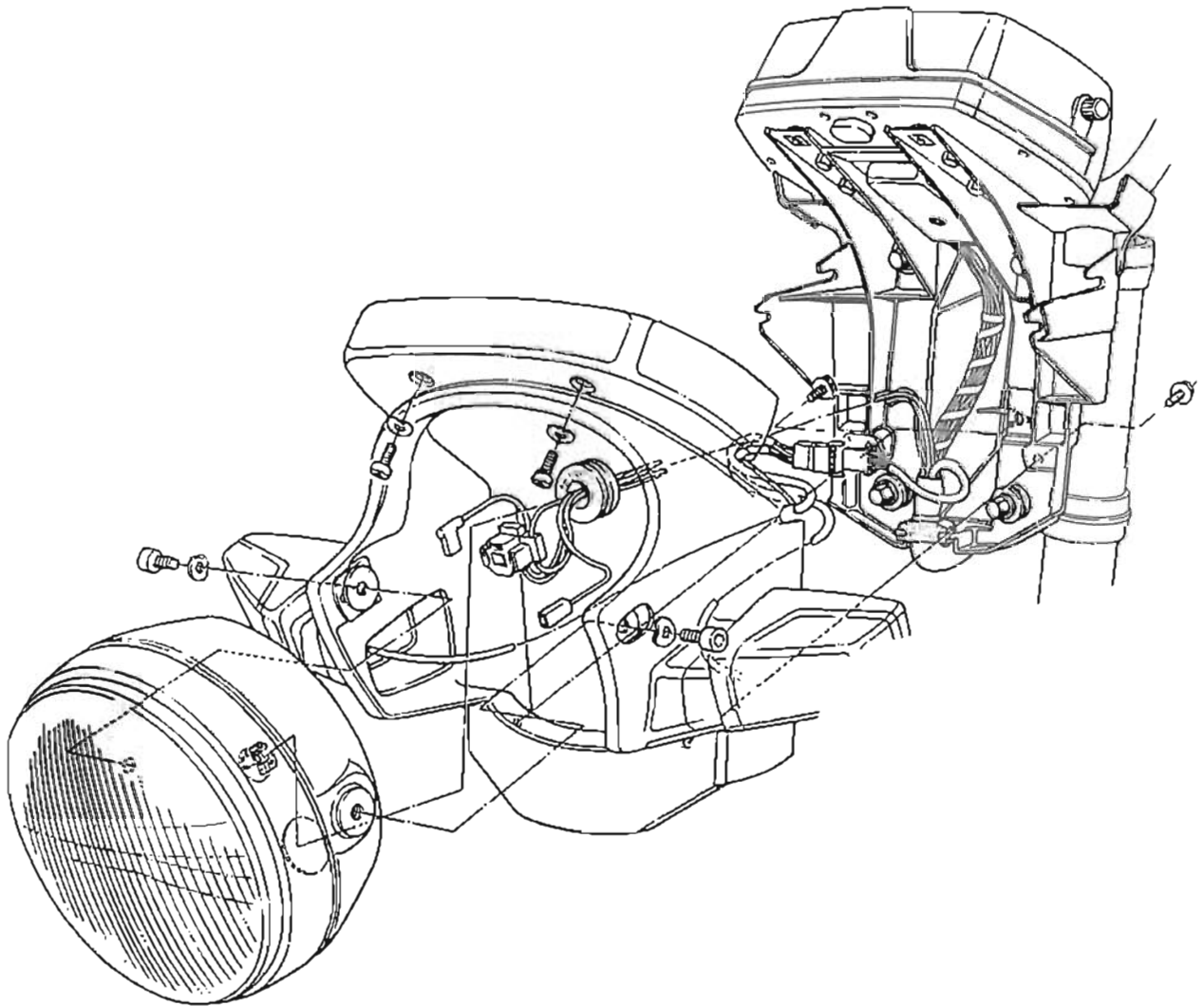

Cockpit fairing – removing and installing

Remove retaining screws (arrows) for cockpit holder on left and right.
Tilt cockpit fairing and turn indicator housing forwards.

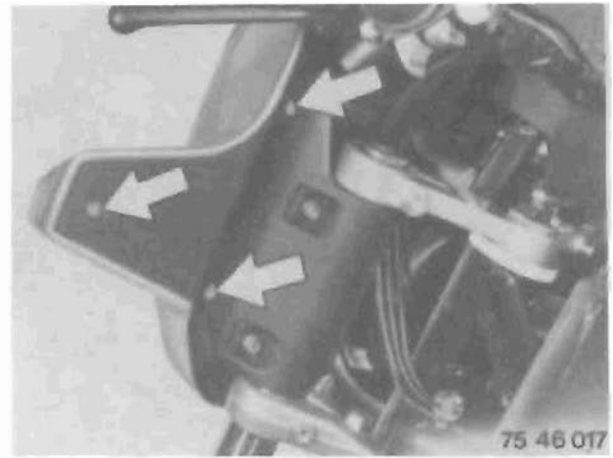

Disconnect turn indicator lead (arrow).
Take off cockpit fairing.



Remove plugs on headlight.
Slacken off retaining screws for headlight and take off headlight.

When installing:
The marks (arrow) on the holder must be aligned when assembling.



Disconnect electric cable (arrow) to the horn.
Remove the retaining screw (circle) for cap (1) and take off cap.
Pull out multi-pin plug.

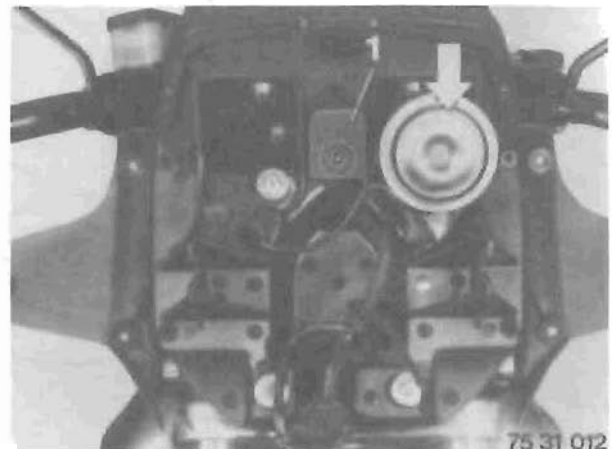

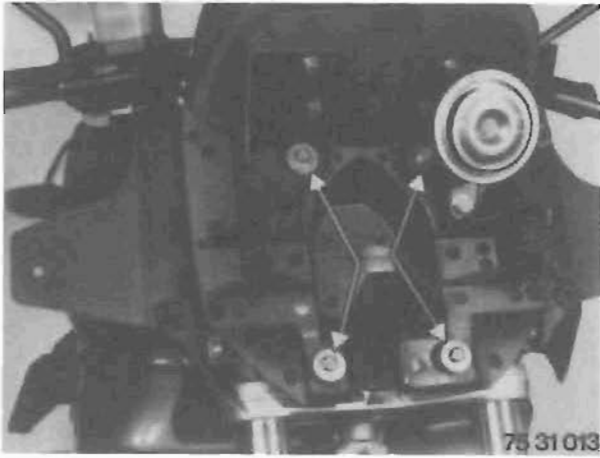

Remove four retaining screws (arrows) for rear panel at the top and base of the fork bridge.

Take off the rear panel and instrument cluster.

Note:

Note the angle between the base of the fork bridge and the rear panel.

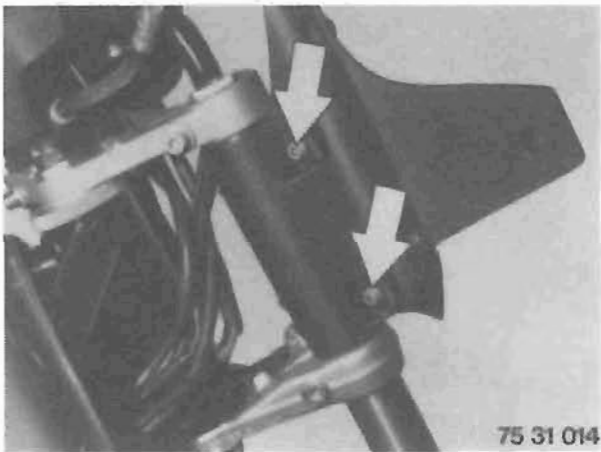

Remove the retaining screws (arrows) on left and right for cockpit holder.

Take off the cockpit holder.

Install following the same procedure but in the reverse order.

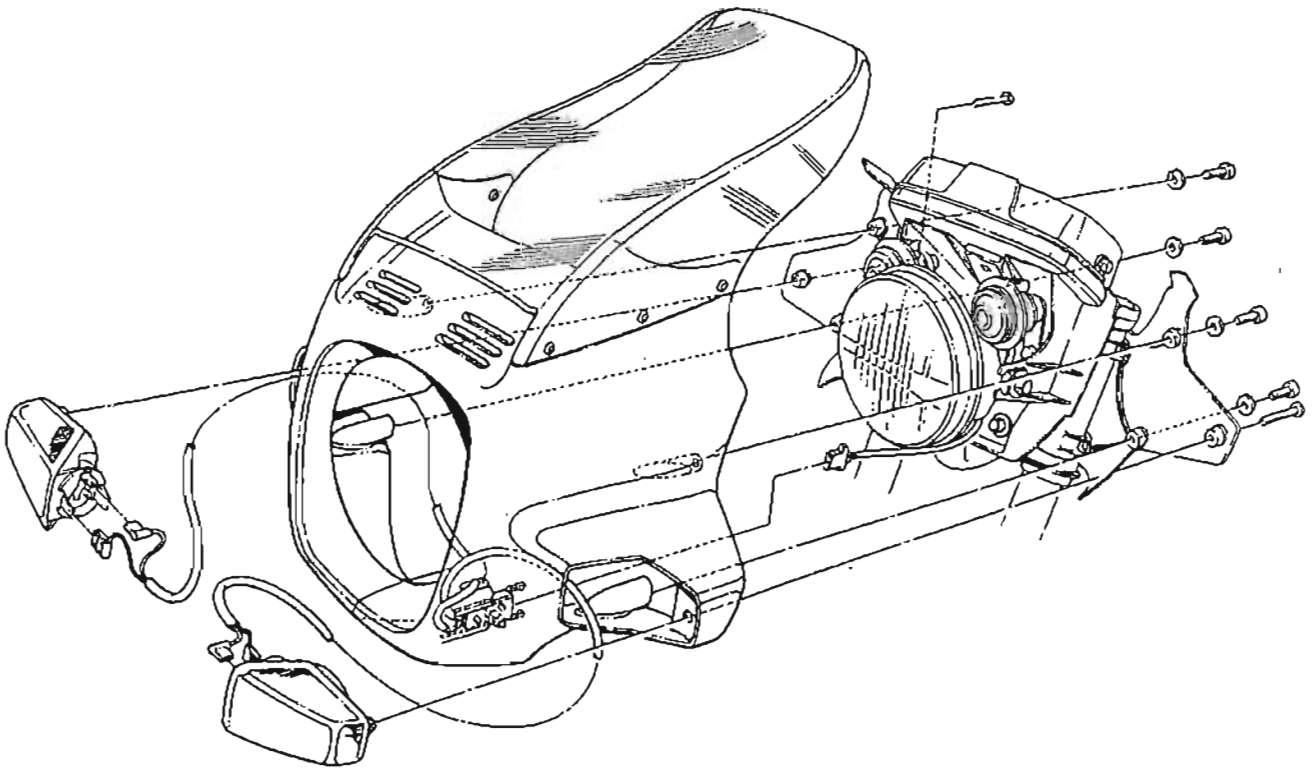

K 100 headlight fairing – removing and installing

Remove retaining screws on left and right (arrows), pull the fairing forwards to remove and allow to hang down freely.

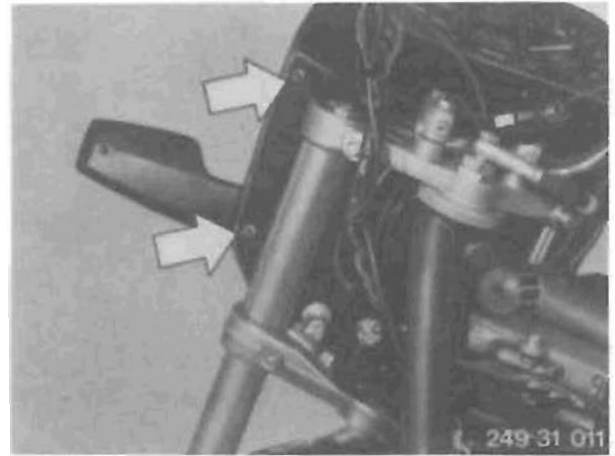

Slacken off the headlight mounting at left and right. Pull the headlight forwards out of holder. Pull electric cable off reflector (arrows).

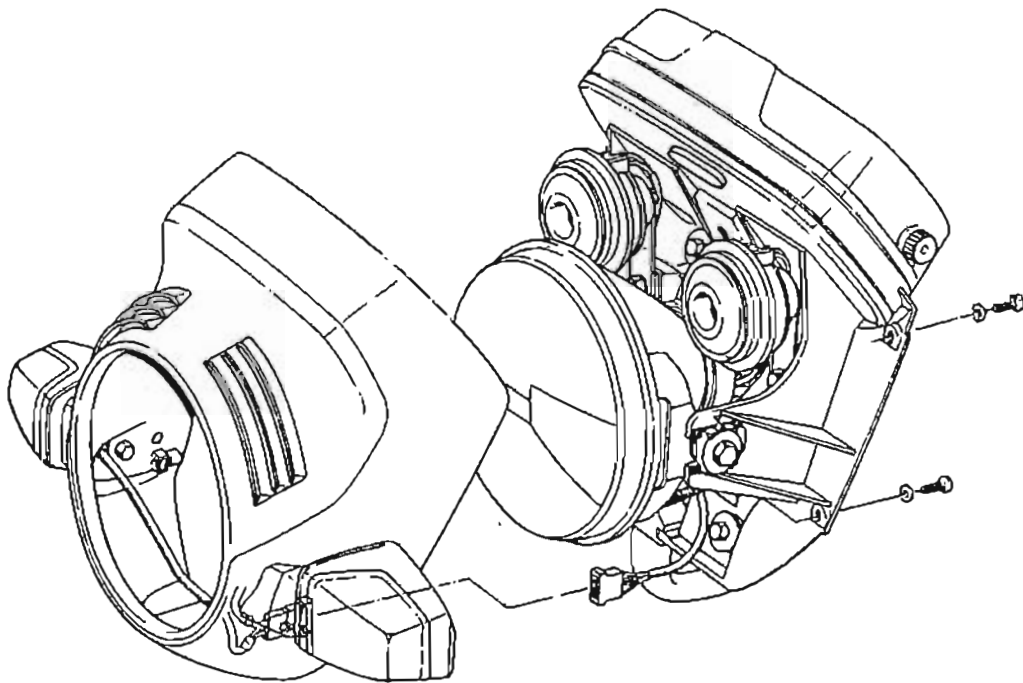



Slacken off hex retaining bolts (arrows) for horn and pull electric cables off the horns.
Remove cover (1) for multi-pin plug in instrument housing and pull out multi-pin plug.

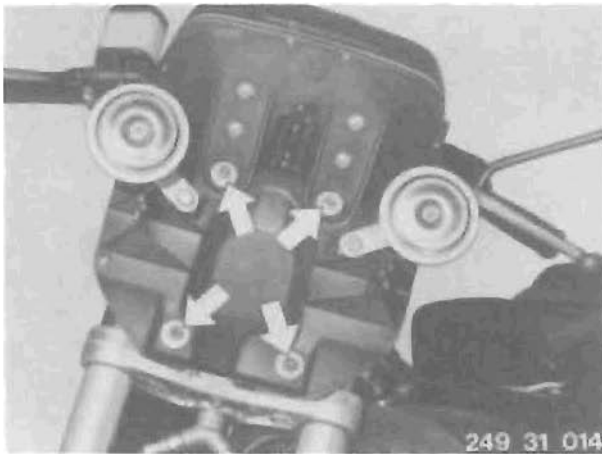

Remove the four Allen screws (arrows) and take off the rear panel together with the instrument cluster.
Install following the same procedure but in the reverse order.

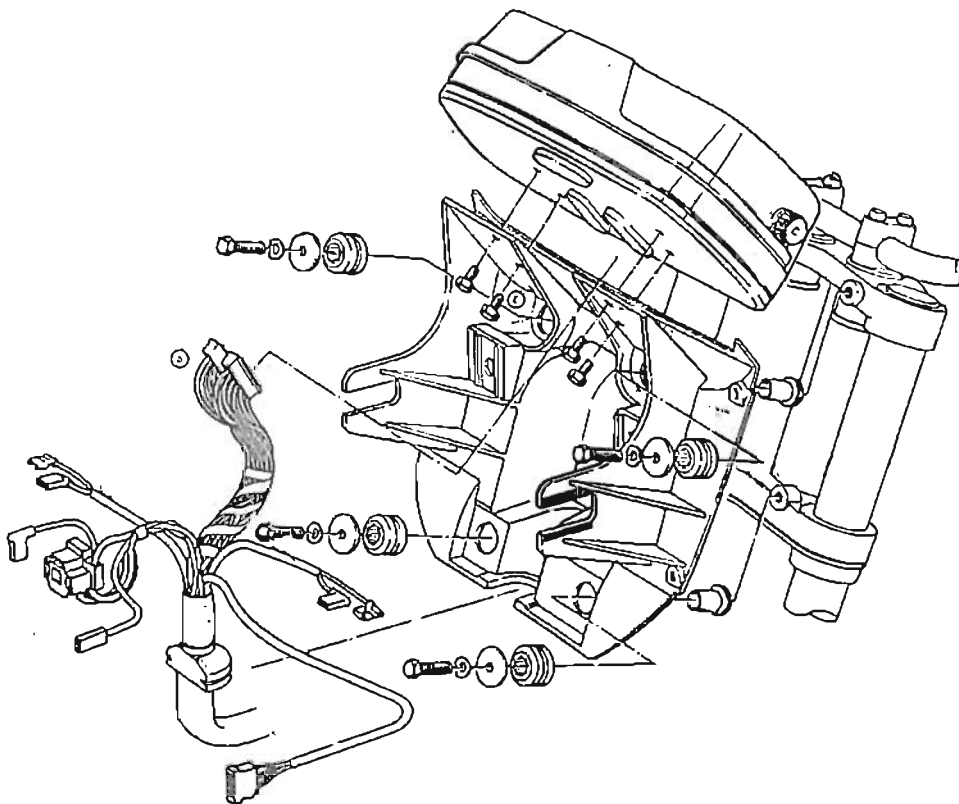

K 75, K 75 c radiator trim – removing and installing

Carefully press radiator trim out of rubber sleeve on right and left at the fuel tank with BMW lever 46 5 700.



Pull radiator trim slightly forward, lower and take off to one side.
Install following the same procedure but in the reverse order.

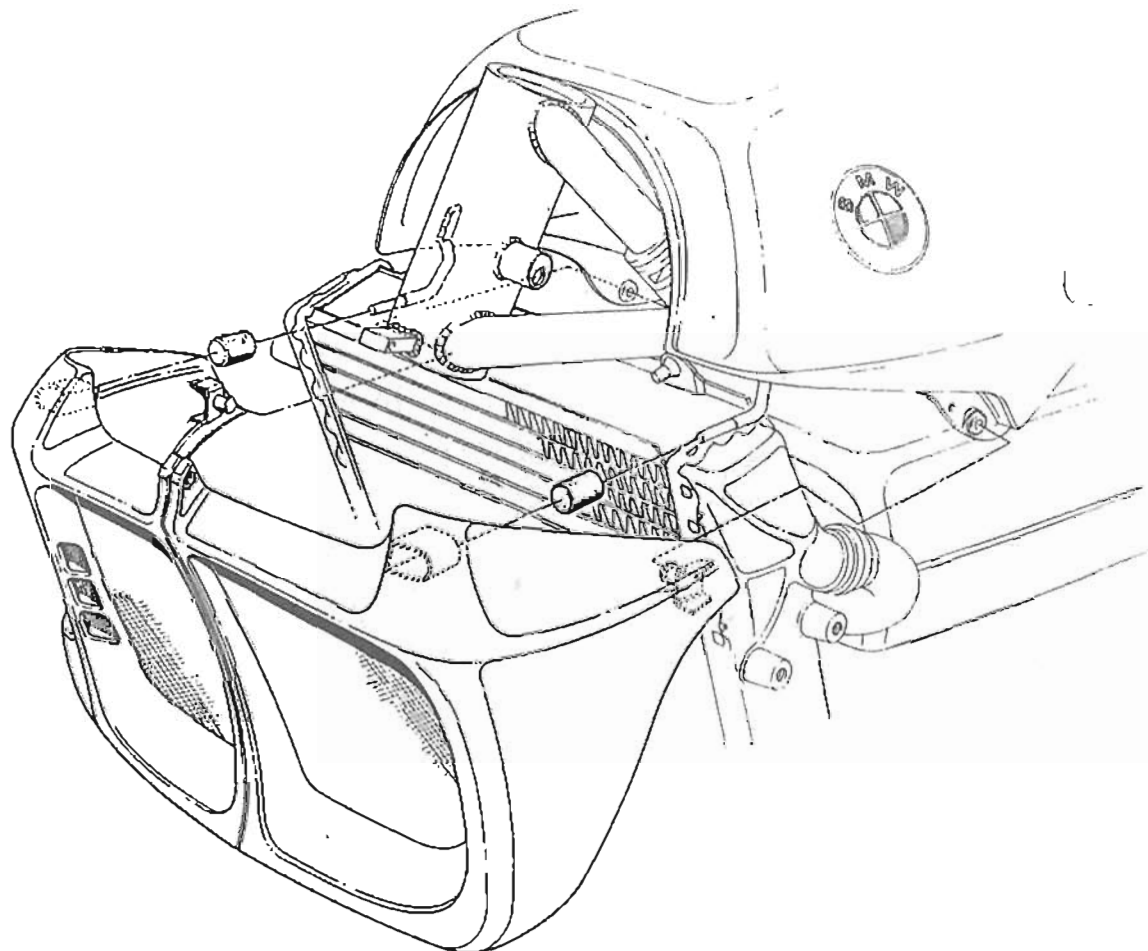

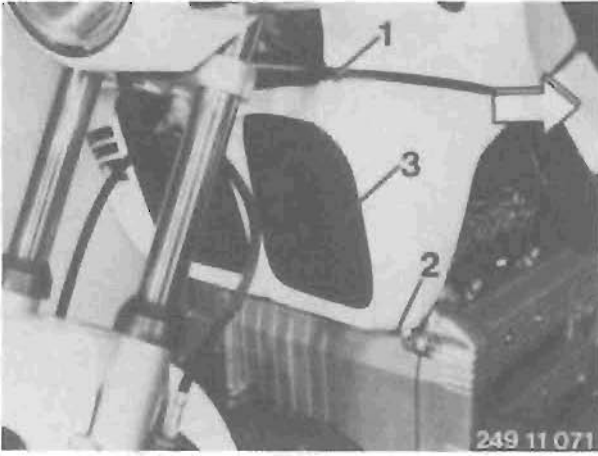

K 100 radiator trim – removing and installing

Remove retaining screws on left-hand side section of radiator trim, then pull out of rubber sleeve on fuel tank (arrow).



Pull right-hand side of radiator trim out of rubber sleeve on fuel tank (arrow) and take off radiator grille with side section.

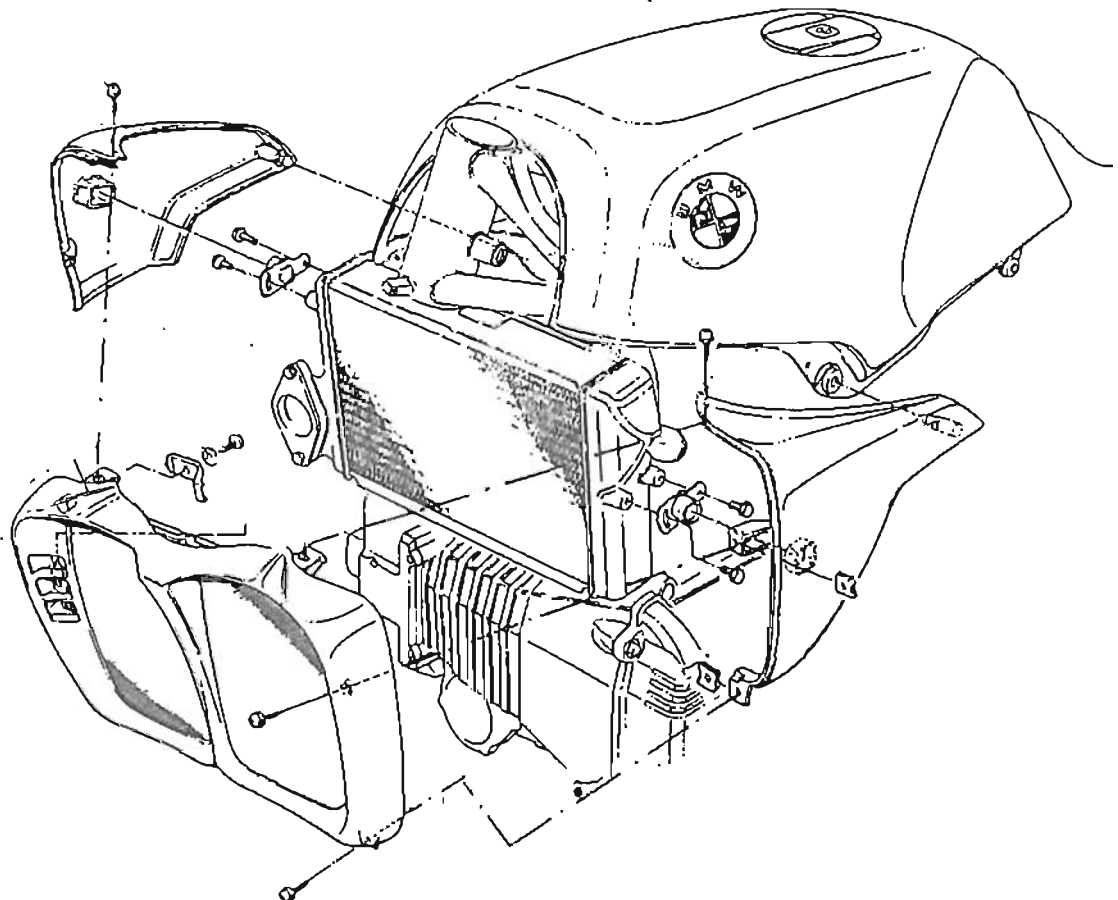

**K 75 s fairing – removing and installing
Windshield – removing and installing**

Remove the four retaining screws (1) for windshield.
Take off windshield.



Radiator trim – removing and installing

Remove the four retaining screws (arrows) for radiator trim.
Take off the radiator trim.
Remove centre retaining screw (1).

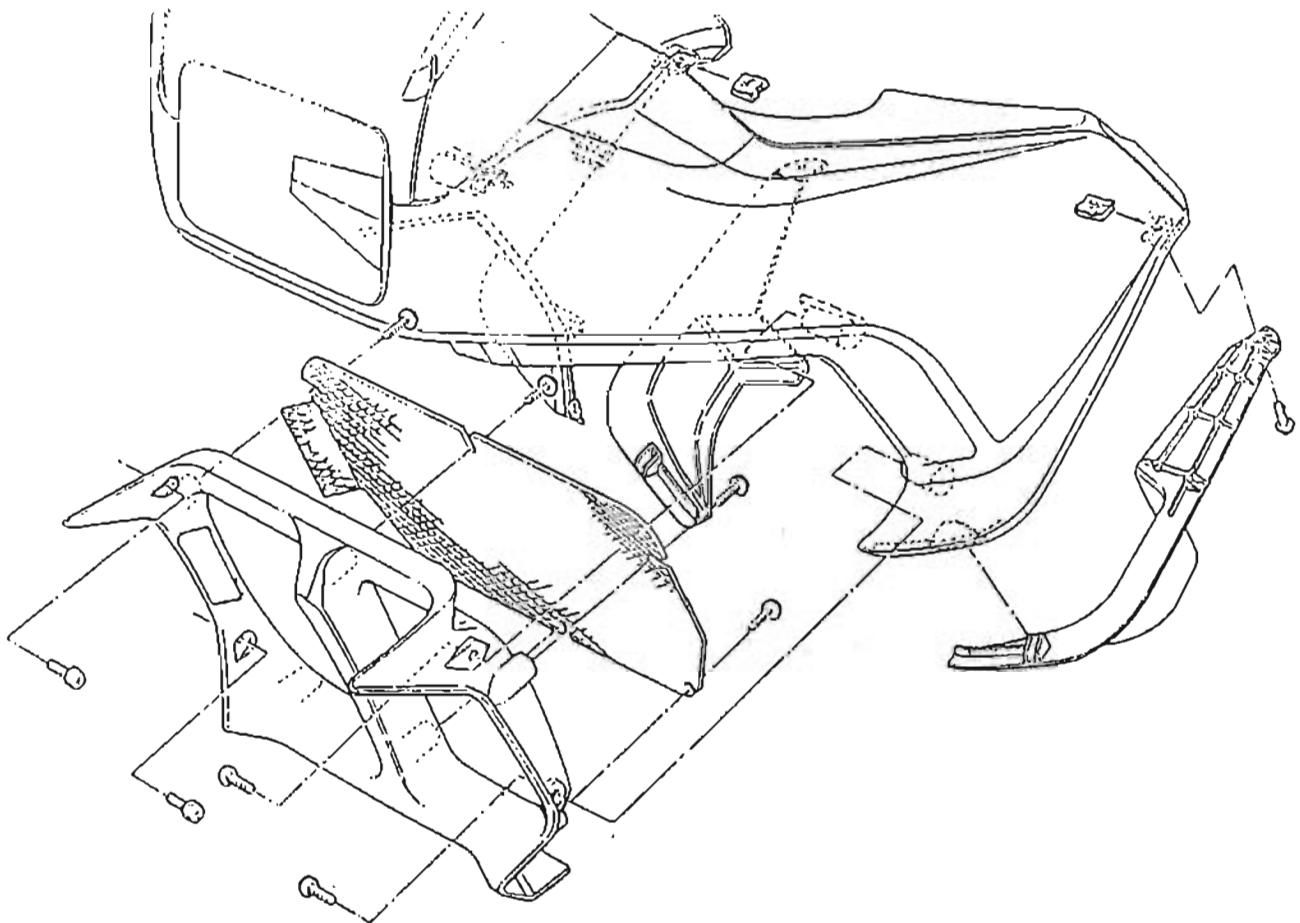
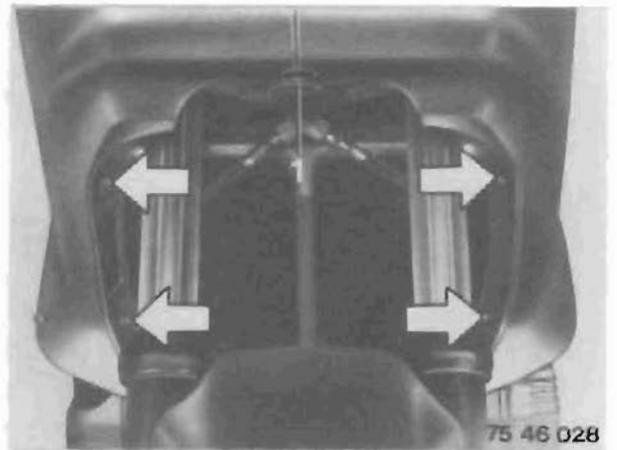

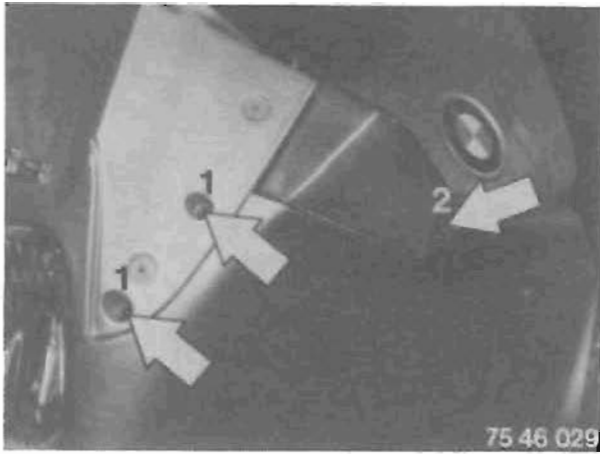

Side fairings – removing and installing

Remove retaining screw (arrow 1) for side fairing.
Remove retaining screw (arrow 2) for turn indicator housing.
Take turn indicator housing out of trim.



Pull off plug connections (1, 2).
Remove top retaining screw (arrow).

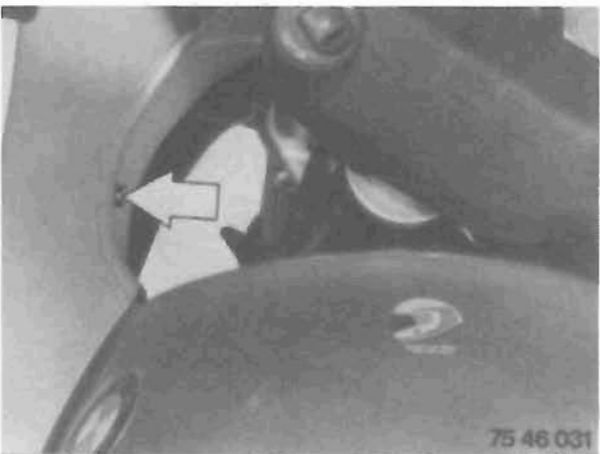

Remove retaining screw (arrow) on fairing inner cover.



Remove lower retaining screw (arrow) for cover.
Take off cover.

Remove retaining screw for fairing holder on frame.
Take off side fairing.

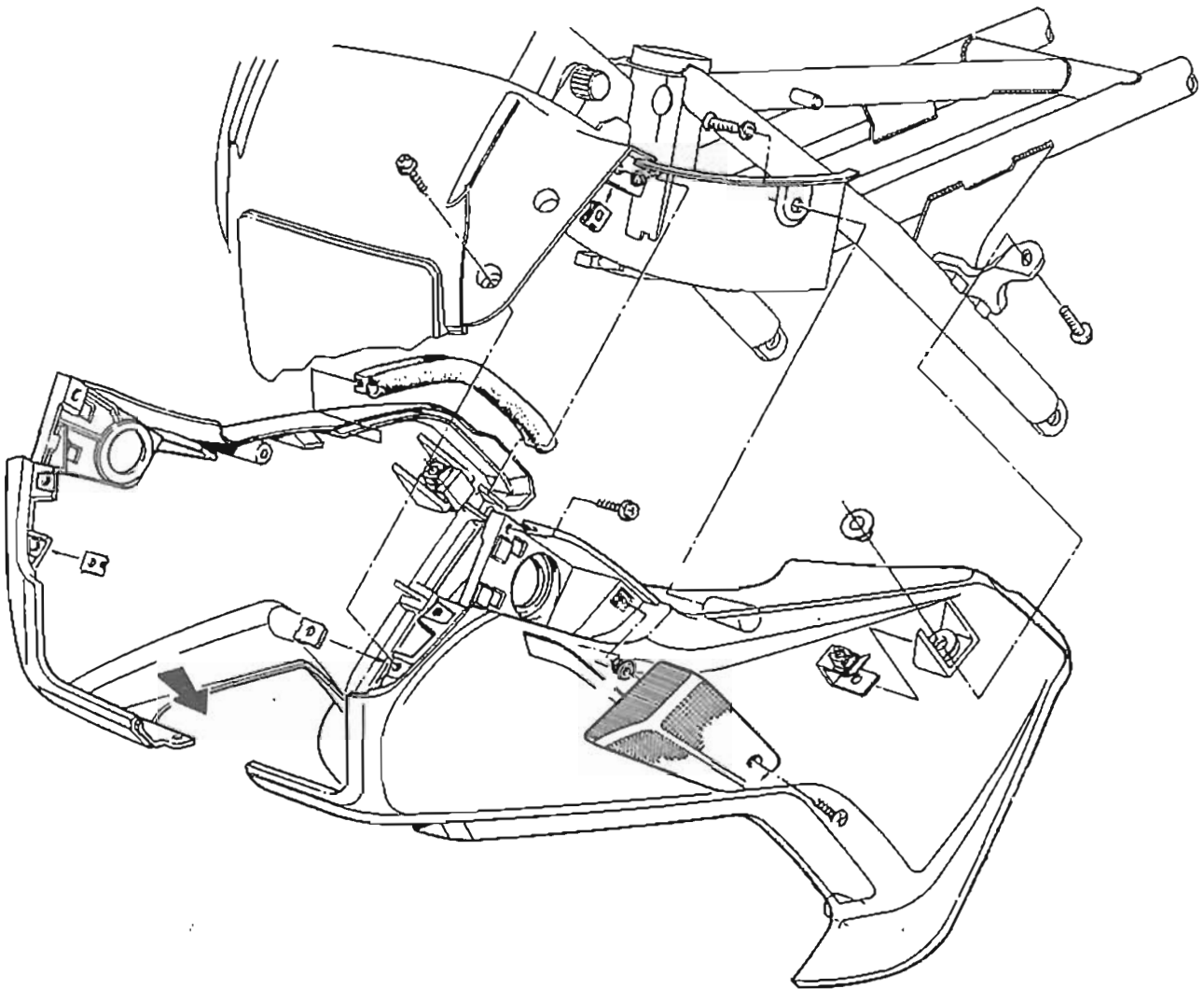

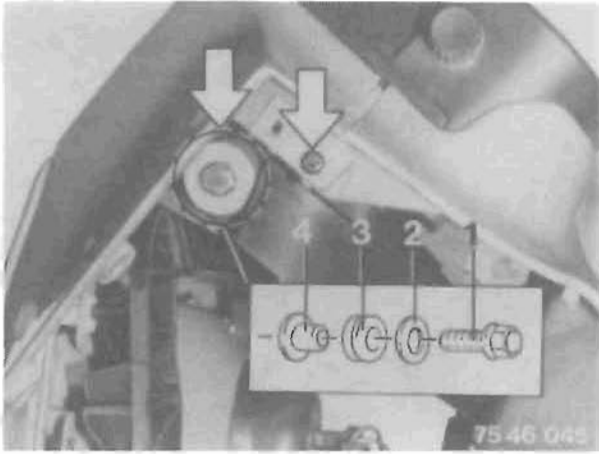

Centre fairing – removing and installing

Remove both retaining screws (arrows) on left and right on centre fairing.

When installing:

Note installation sequence of screws (hex screws):

- 1 Screw with spring washer
- 2 Washer
- 3 Rubber bushing
- 4 Plastic sleeve

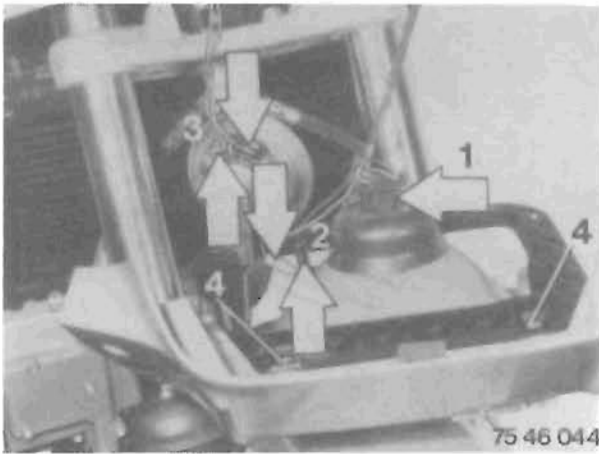

Take off centre fairing.

Disconnect the following leads (arrows):

- Combination plug for H4 bulb (1) [brown/yellow/white]
- Parking light bulb (2) [grey/white/brown]
- Horn (3) [green/grey/brown]

Disconnect retaining screws (4) on headlight ring.

Take off headlight ring together with headlight and horn.

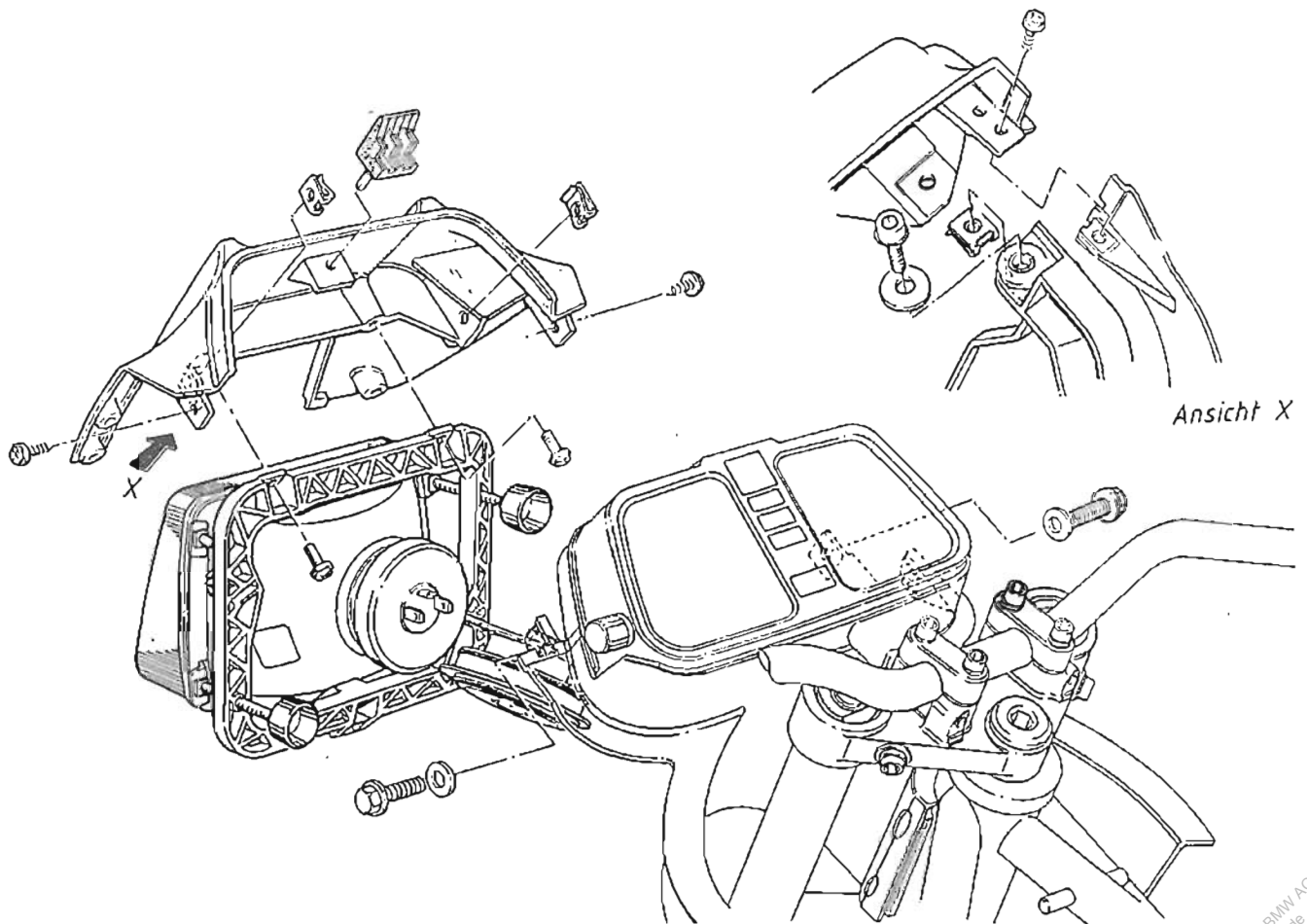

Instrument cluster – removing and installing

Take off cap (1) for instrument cluster plug connection.
Pull out plugs (2 and 3).



Remove four retaining screws (arrows) for instrument cluster.
Take off the instrument cluster.

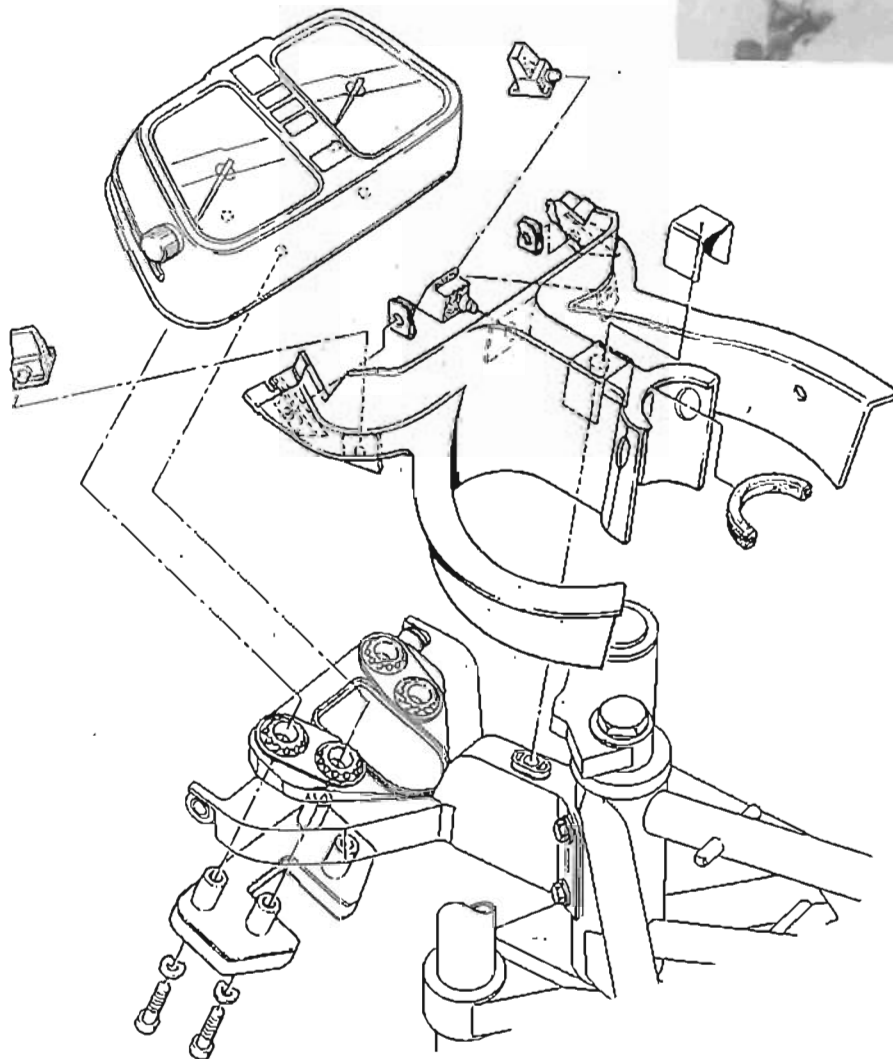
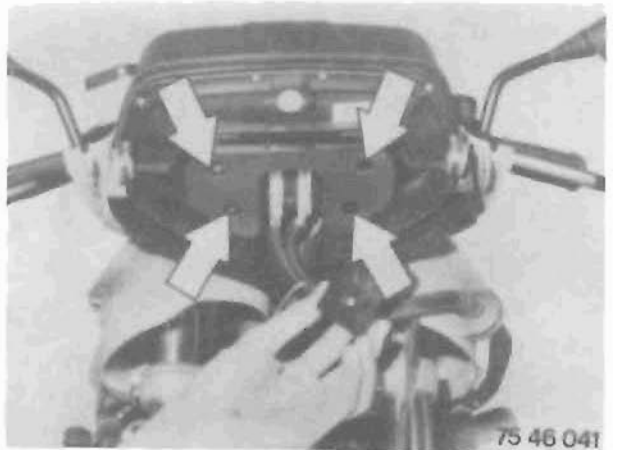

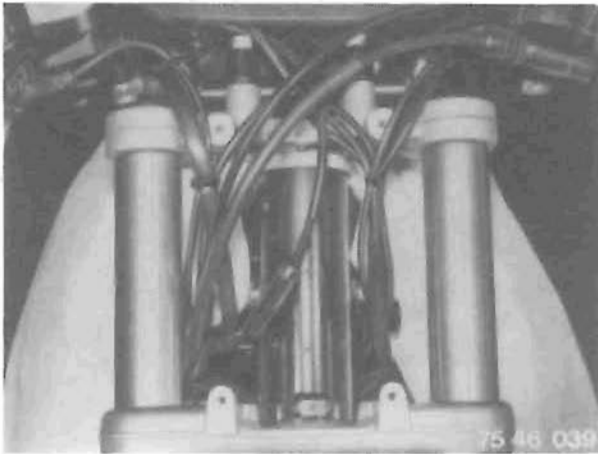

Fairing mounting – removing and installing

Remove both retaining screws for fork bridge trim and take off trim.

When installing:

When assembling the fork bridge trim, ensure that the electric cables and wire cables are properly located. Run the wire cables above the electric cables.

Note:

The fairing mountings have been removed here to provide a better picture.

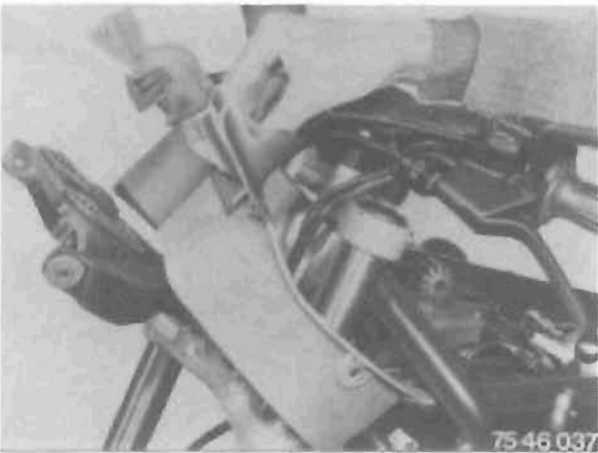

Remove cable strap for wiring harness on inner cover.

Lift out the inner cover.

Slacken off the fairing mounting retaining screws if necessary.



Remove the two retaining screws (1 and 2) on each side of the fairing mounting.

Take off the mounting.

When installing:

Screw (1) is of a tapered type for securing the fluidbloc; no other type of screw and no screw of a different length may be used.

Tightening torque:

Taper screw

$9 \pm 1 \text{ Nm}$

K75s

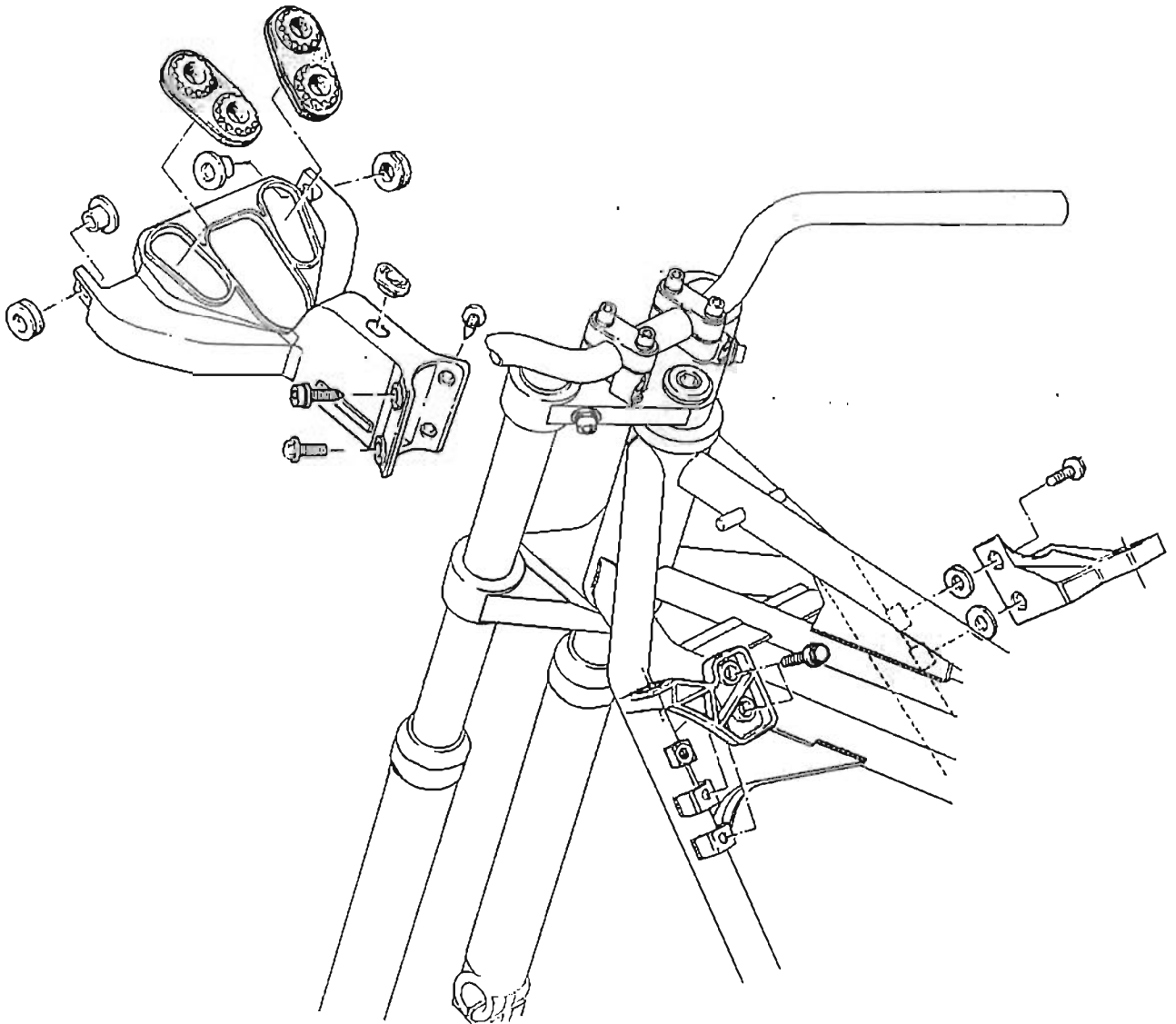

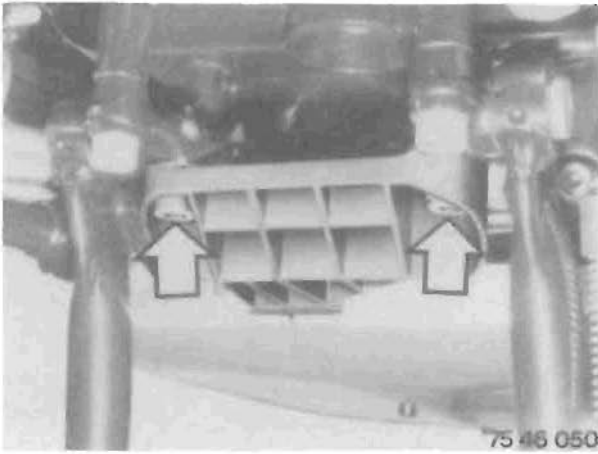

Engine spoiler – removing and installing

Remove two retaining screws (arrows) for rear holder on pivot block.

Note:

Note the shims between the holder and pivot block.

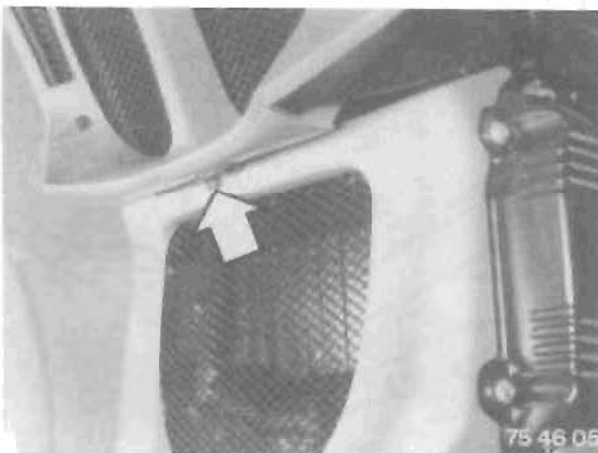

Remove retaining screw (arrow) for holder on radiator trim.

Note:

Note plastic shim between the holder and radiator trim.

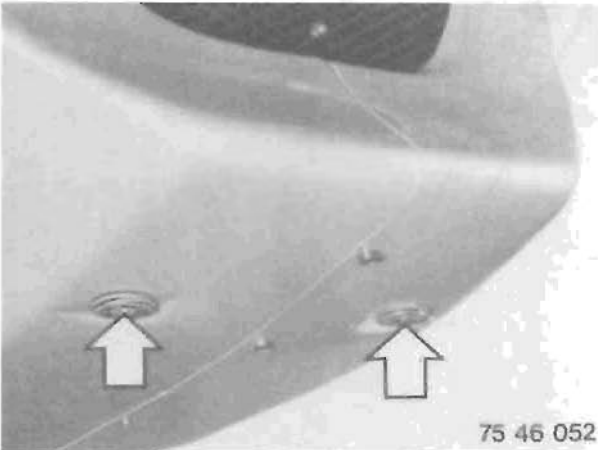

Remove both retaining screws (arrows) on underside of engine spoiler.



Pull the engine spoiler slightly down at the rear and pull forward out of the front holder.

When installing:

First push the engine spoiler with rubber bushing into the front holder.

Remove retaining screws (arrows) for holder on oil sump and take off the holder.

Install following the same procedure but in the reverse order.

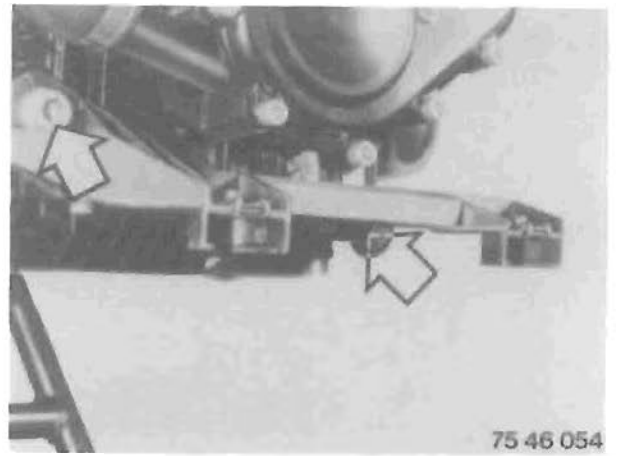

75 46 054

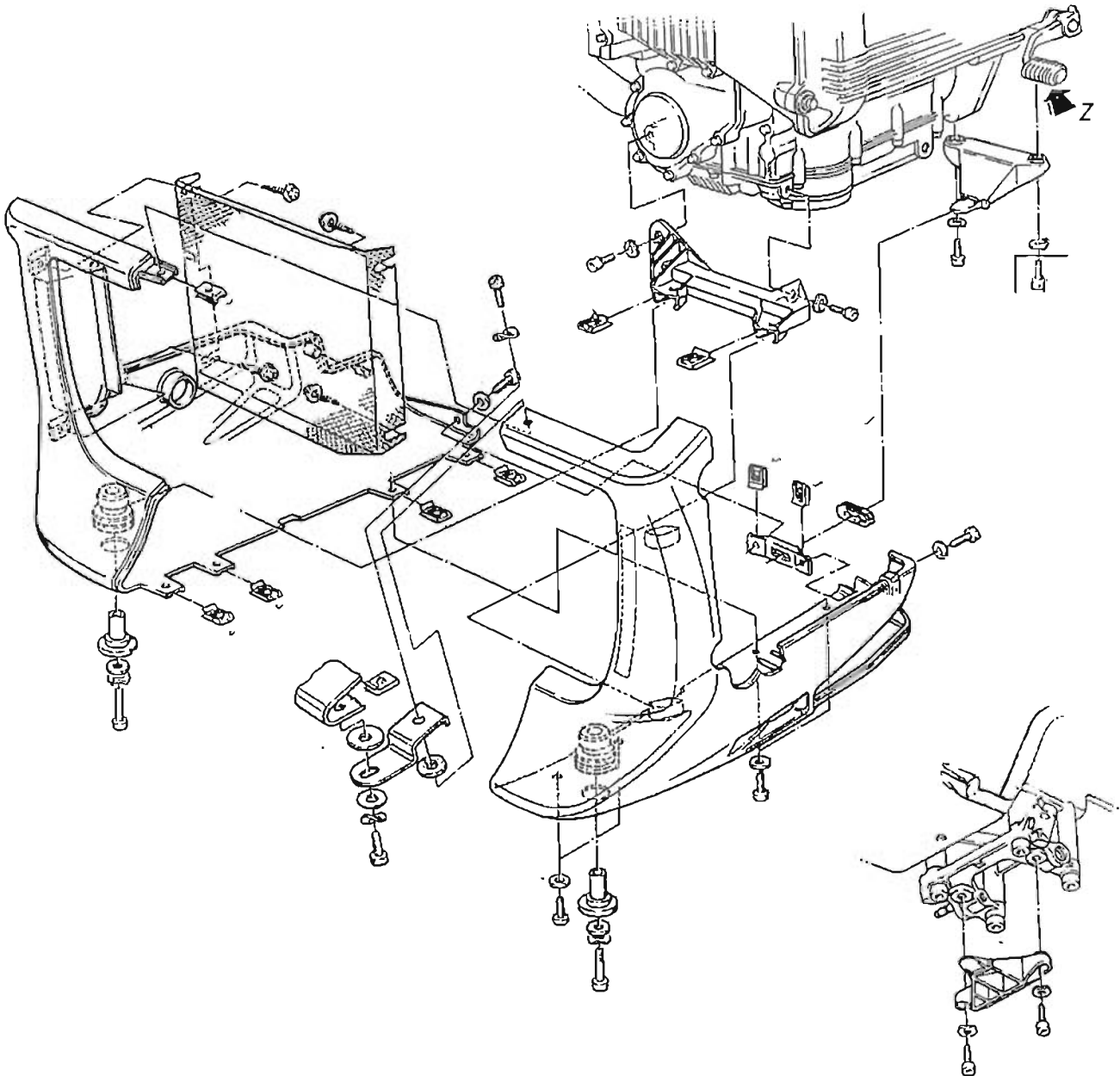

Ansicht Z

K 100 RS fairing – removing and installing

Knee pads – removing and installing

Remove retaining screw (arrow) at base of side section

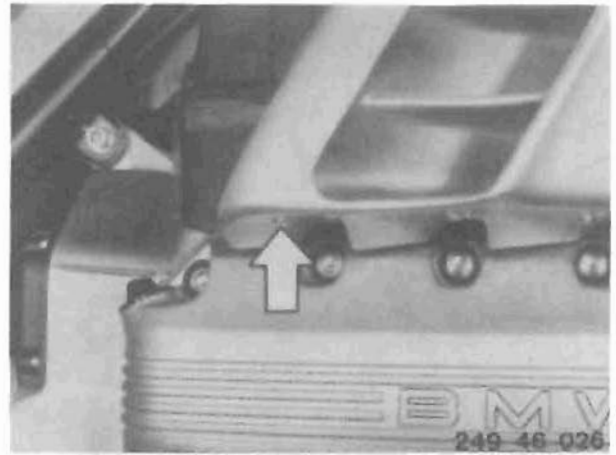

... and take out retaining screws in upper fairing (arrows);
take out the knee pad.

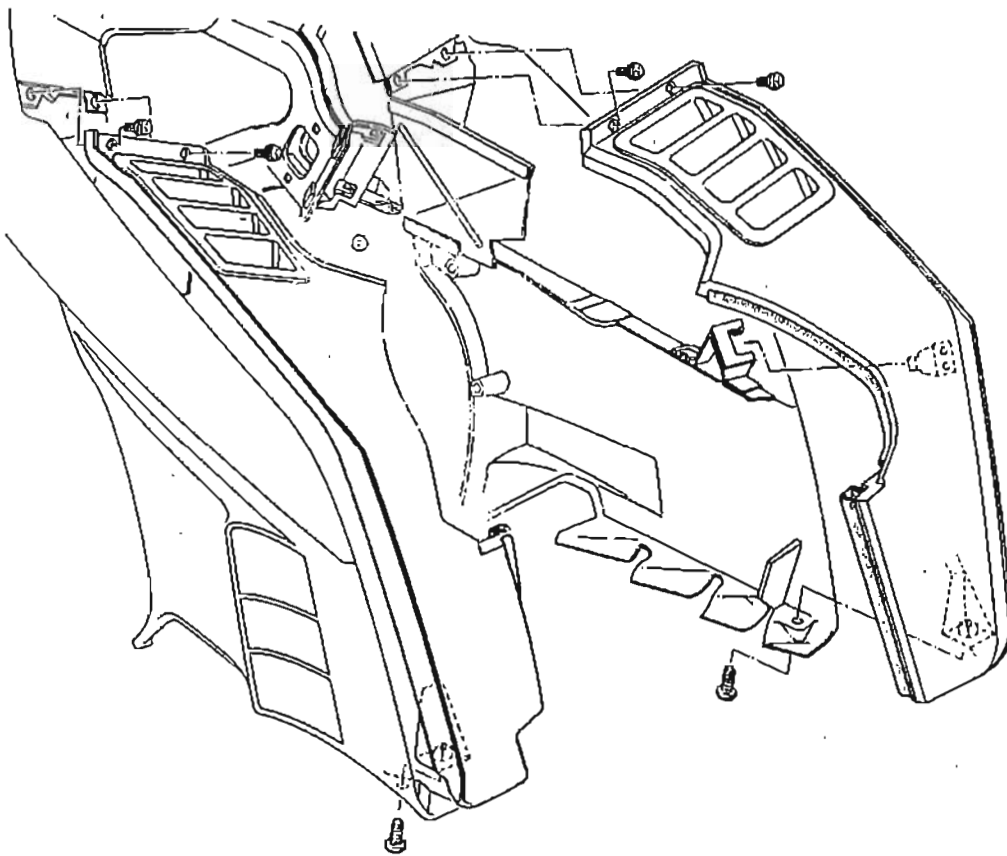
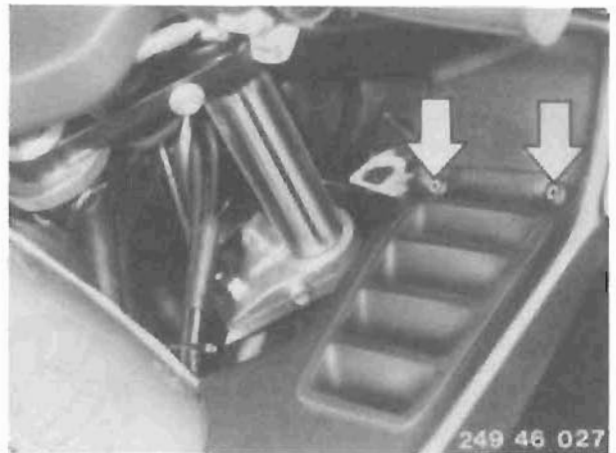

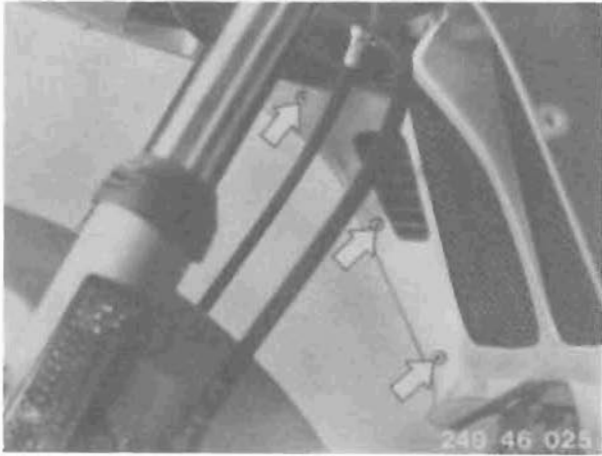

Side fairings on left or right – removing and installing
Remove retaining screws (arrows) in radiator trim.

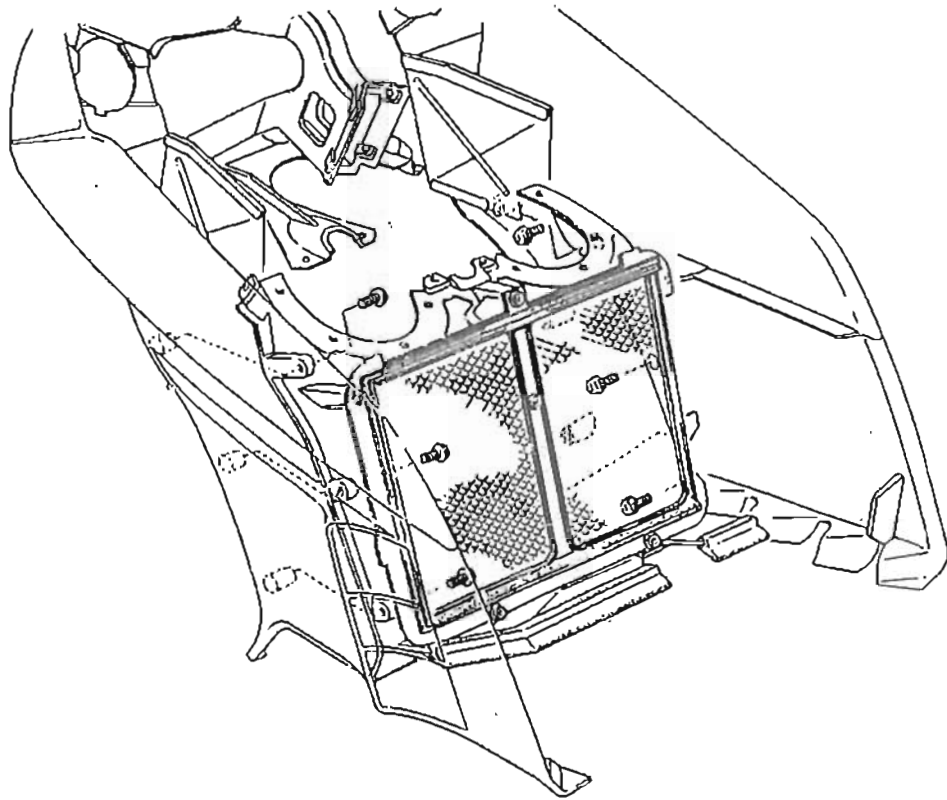

Remove retaining screw (arrow) on holder on engine block.

Remove lower fairing retaining screws on upper section and take off lower fairing.

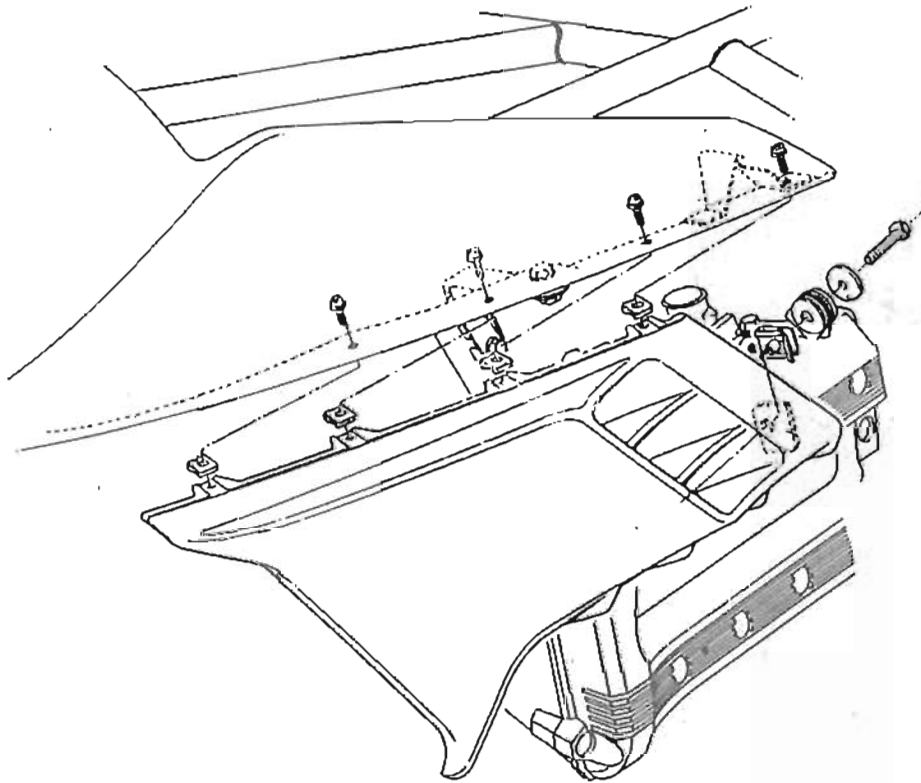
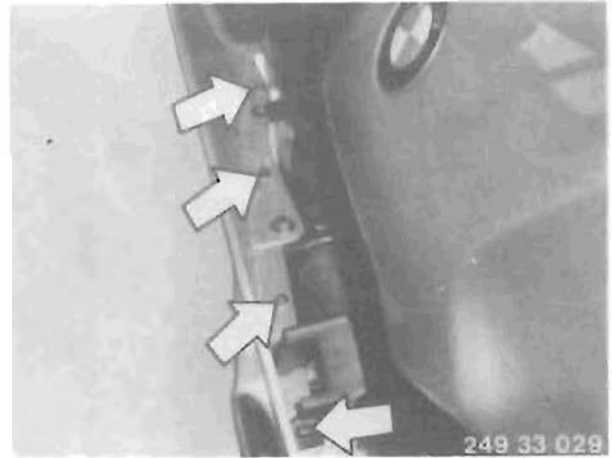

Radiator trim – removing and installing

Remove retaining screws for radiator trim on centre section.

Remove retaining screws for sealing gaiters on radiator trim. Take off the radiator trim.

When installing:

When installing, ensure that the air duct on the radiator trim is correctly fixed to the intake pipe; slacken off the intake pipe on the radiator if necessary.



Mirror with integral turn indicator – removing and installing

Gently strike the underside of the mirror with the palm of the hand, holding the mirror secure with the other hand. If necessary, push the mirror up until free at all three holders.

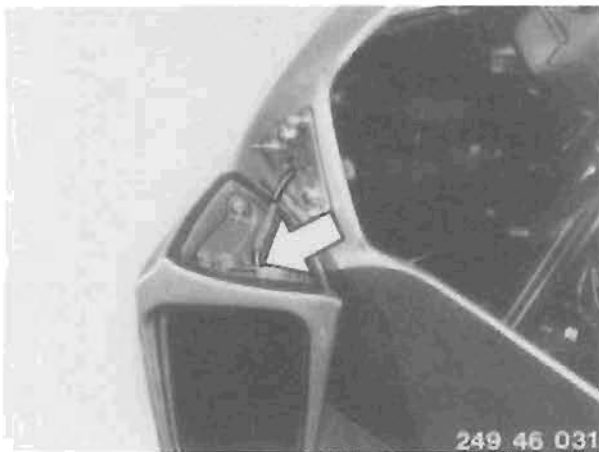

Pull electric cables off the mirror and take off the mirror.

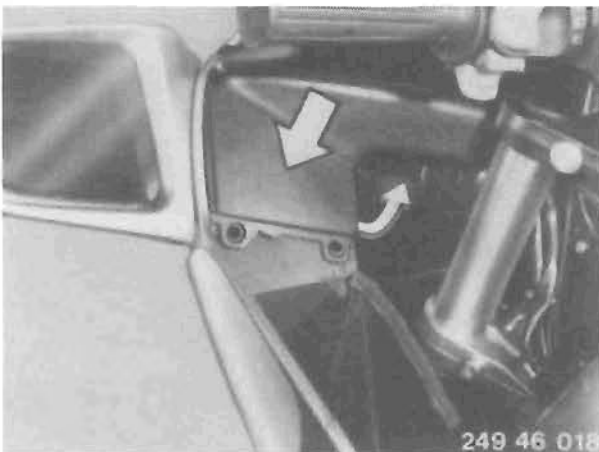

Inner fairing – removing and installing

Fold up the cover (arrow) at the lower edge (engaged) and take off.



Remove retaining screws for inner trim (arrows) and take out the inner section.

Remove retaining screw for top section (arrow) from outside (the horn has been removed to provide a better picture).

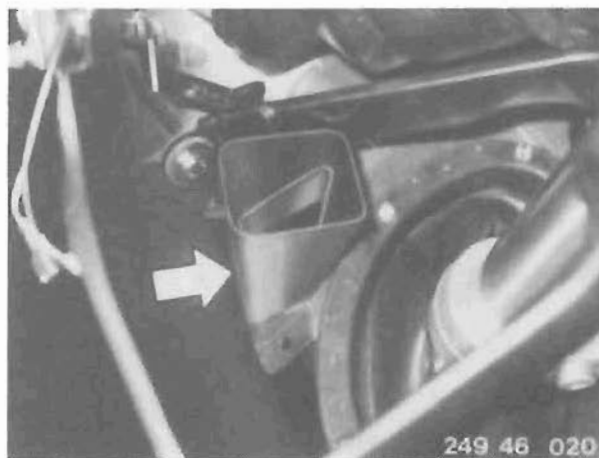

Remove the inner fairing on either side of the windshield (arrows) and pull out to the side.

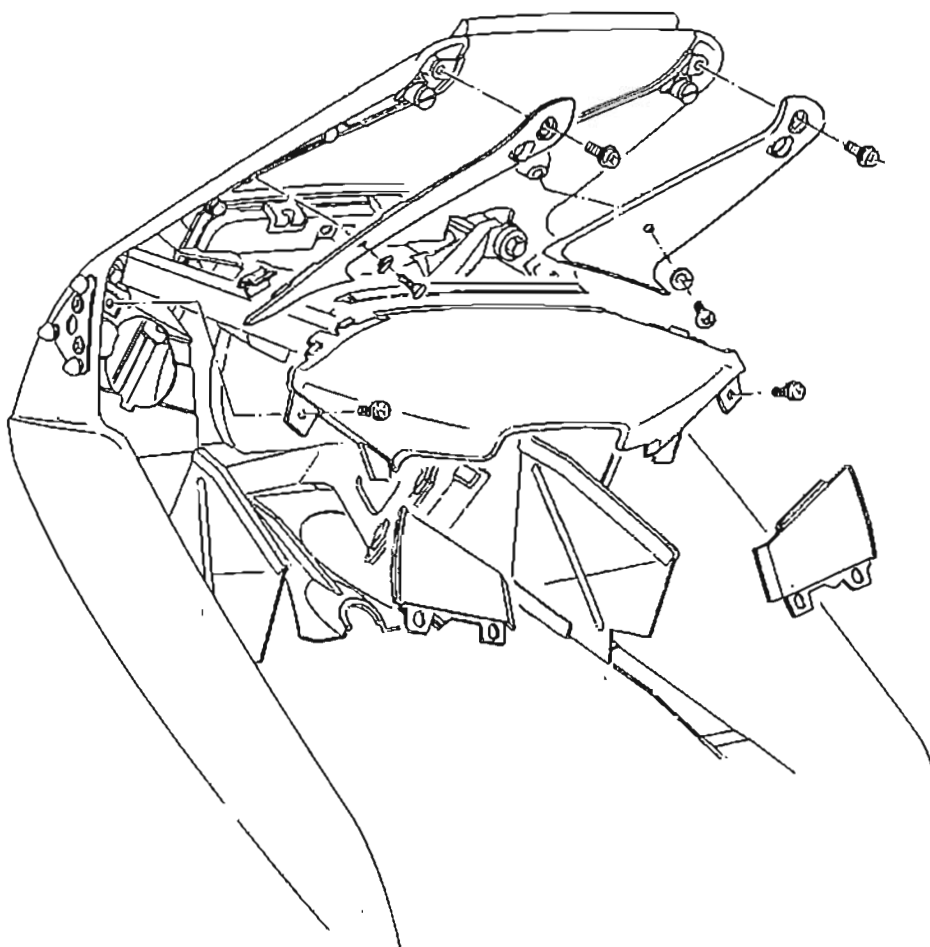
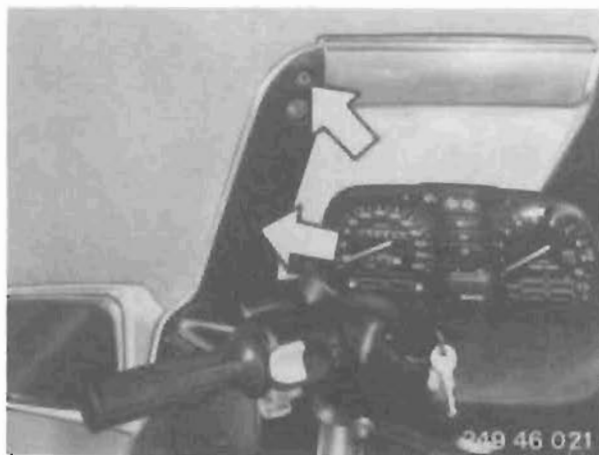

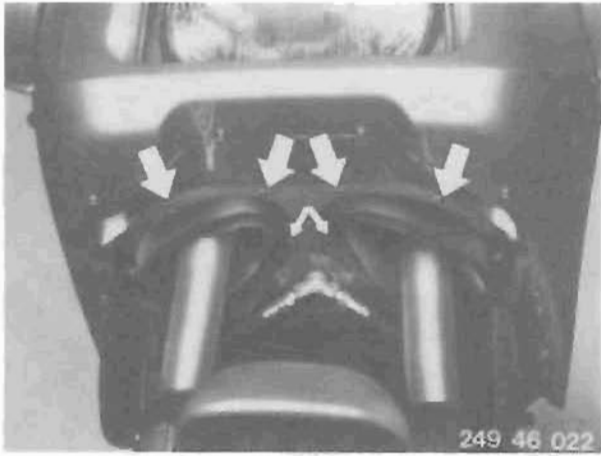

Upper fairing—removing and installing

Remove sealing gaiter retaining screws at trim (arrows).

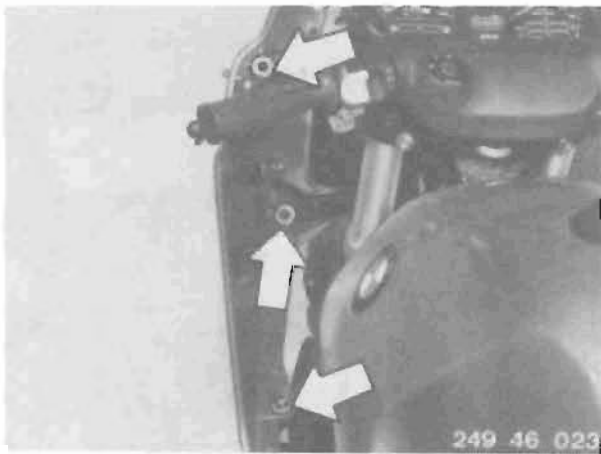

Pull off electric cables on the horns and headlight. Remove retaining screws (arrows) on either side on the fairing mounting and frame, and take off the upper fairing. (The horn has been removed to provide a better picture).

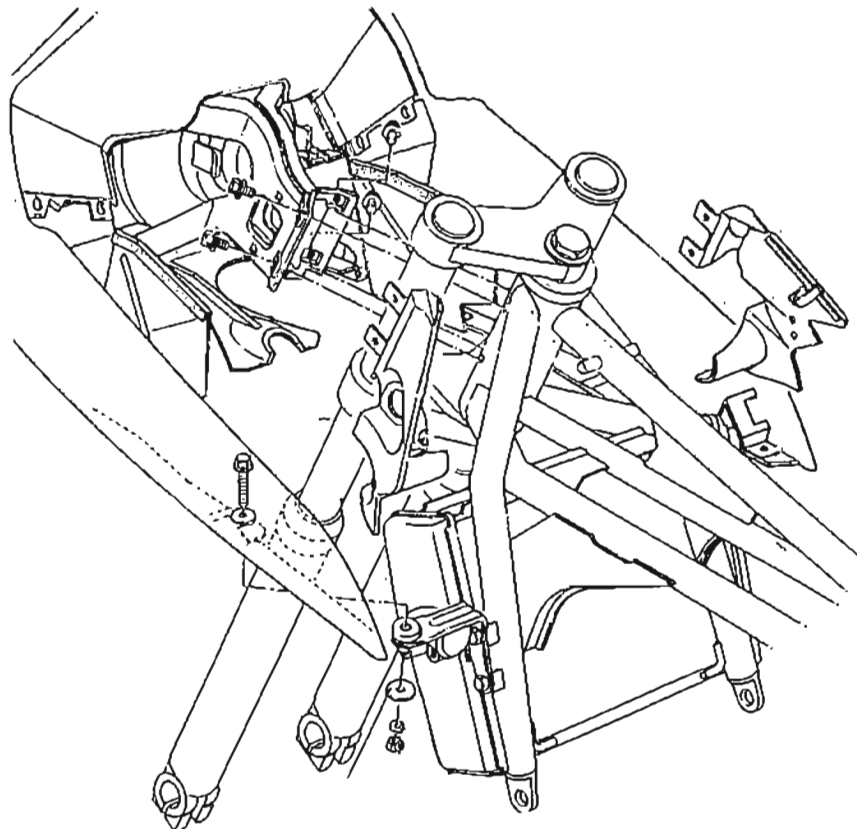

Fairing mounting – removing and installing

Remove retaining screws (arrows) on left and right and take off plastic cover on left and right.

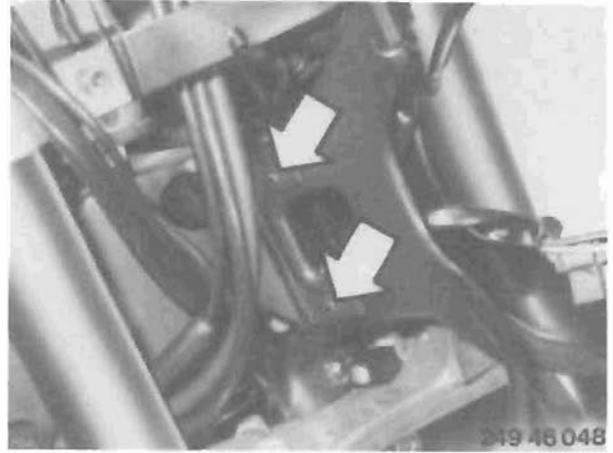

Disconnect cable straps (arrows) on fairing holder. Remove retaining screws (arrows) on left and right, and take off the fairing mounting.

Install following the same procedure but in the reverse order.

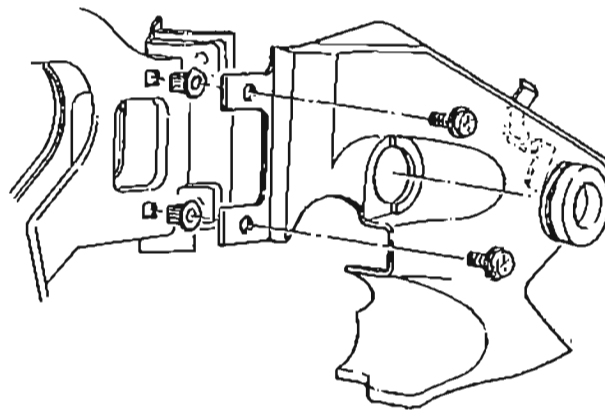
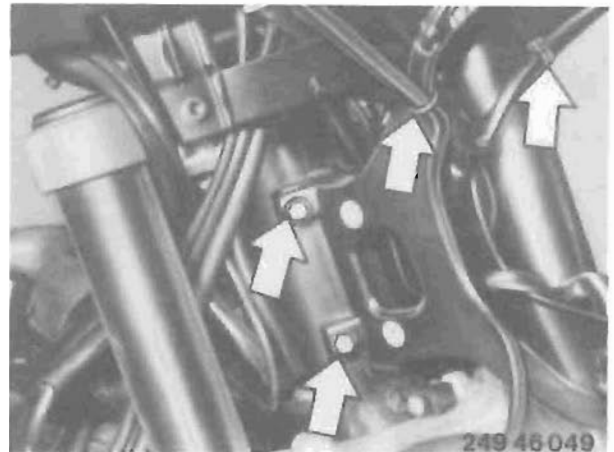

**K 100 RT, LT fairing – removing and installing
Storage compartment and knee pads on either side –
removing and installing**

Open the storage compartment and remove the retaining screws (arrows) for the storage compartment and knee pads on either side.

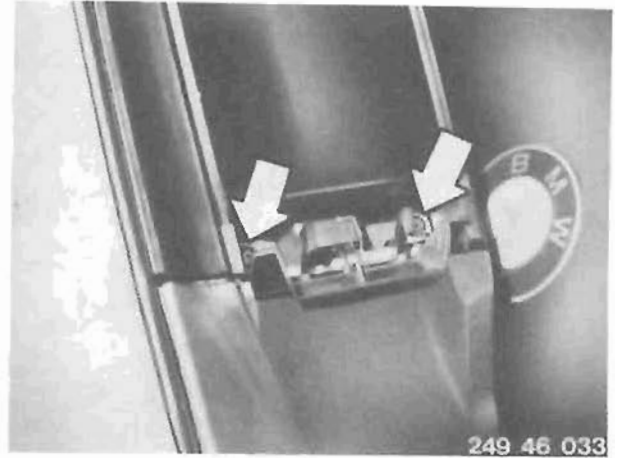

Remove retaining screws at base on either side (arrow).

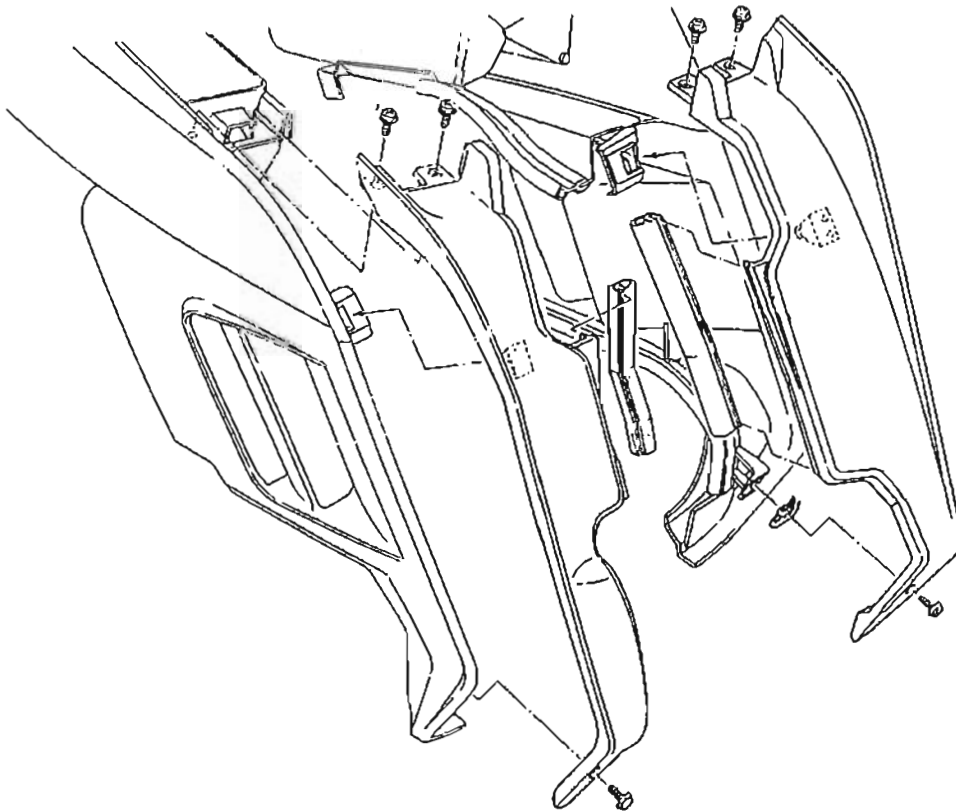

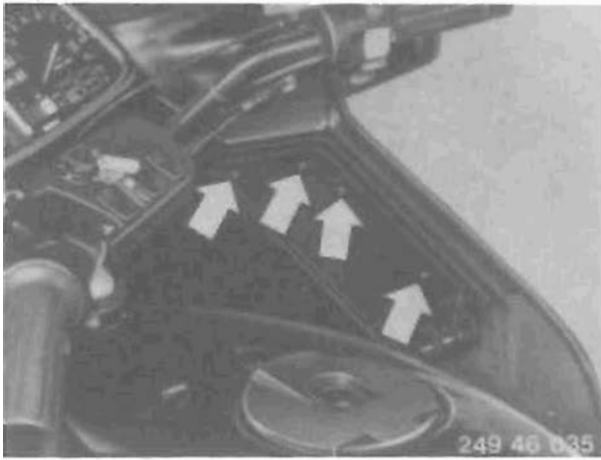

Remove retaining screws on either side for storage compartment (arrows).

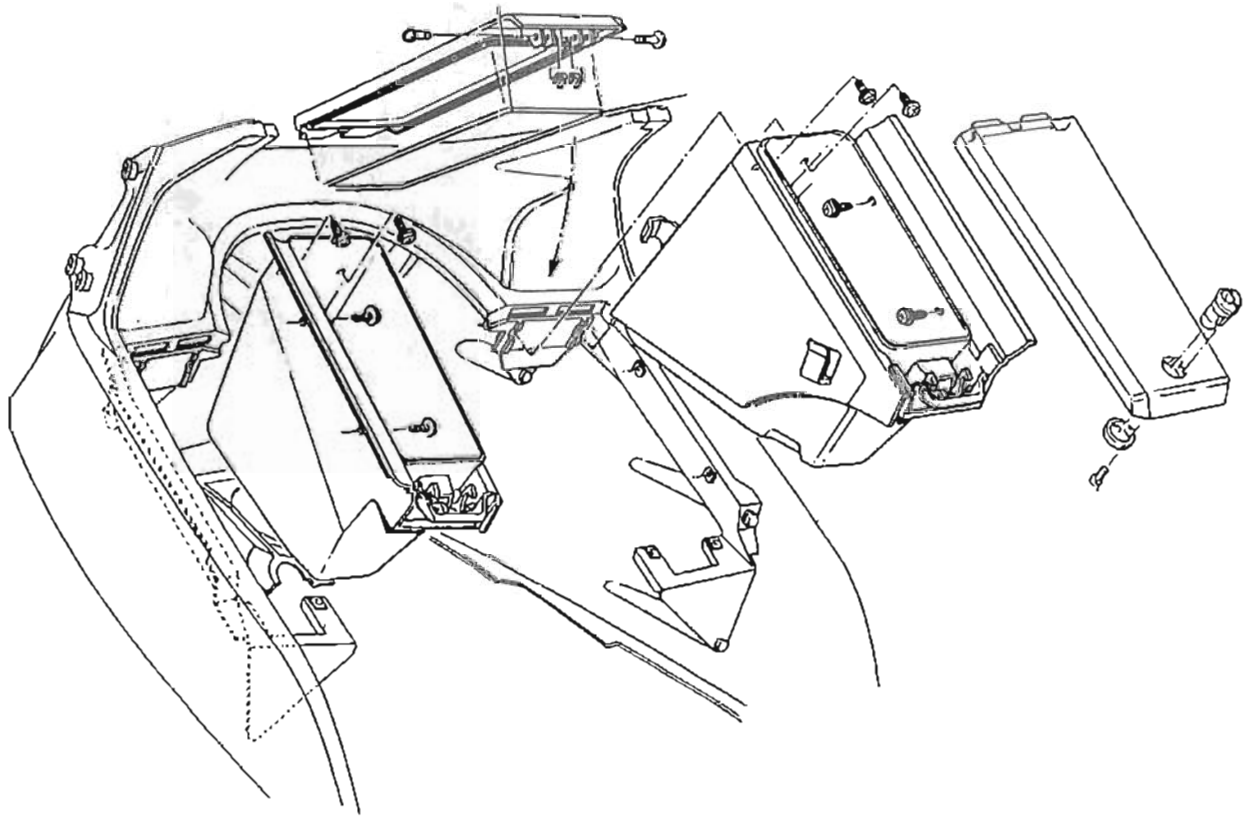

Lower fairing – removing and installing
Remove retaining screws and take out the divider.

Remove retaining screws in the radiator trim on either side (arrows).
(See also illustration on next page.)

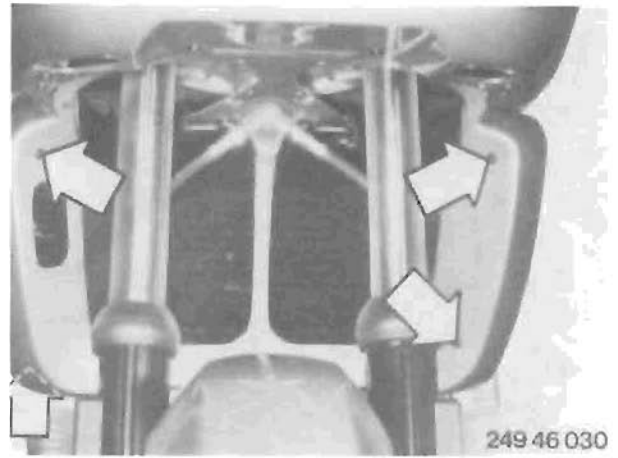

Remove retaining screws (arrows) in the vicinity of the cylinder head/crankshaft cover and take off the lower sections.

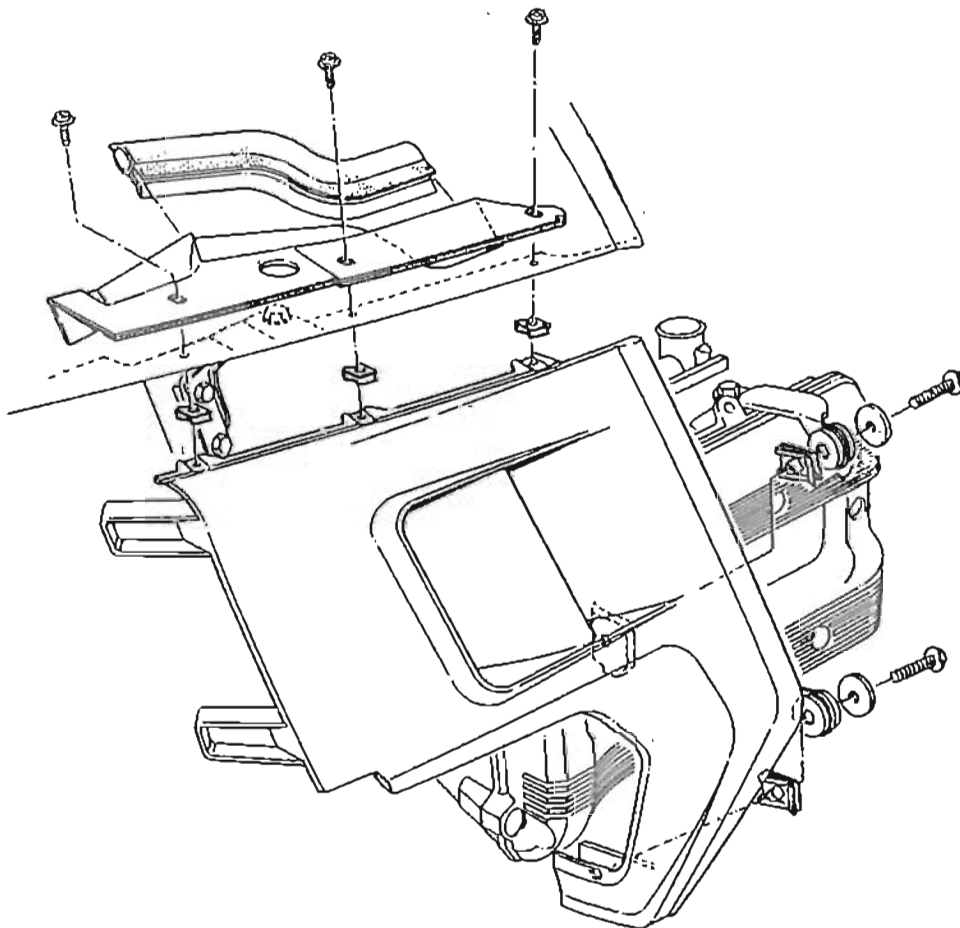

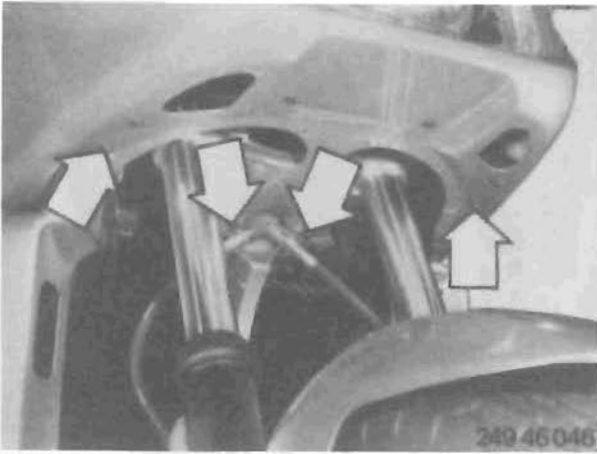

Radiator fairing – removing and installing

Remove retaining screws (arrows) at top of radiator trim and take off the radiator trim.

When installing:

When installing, ensure that the air duct on the radiator trim is correctly fixed to the intake pipe; slacken off the intake pipe on the radiator if necessary.

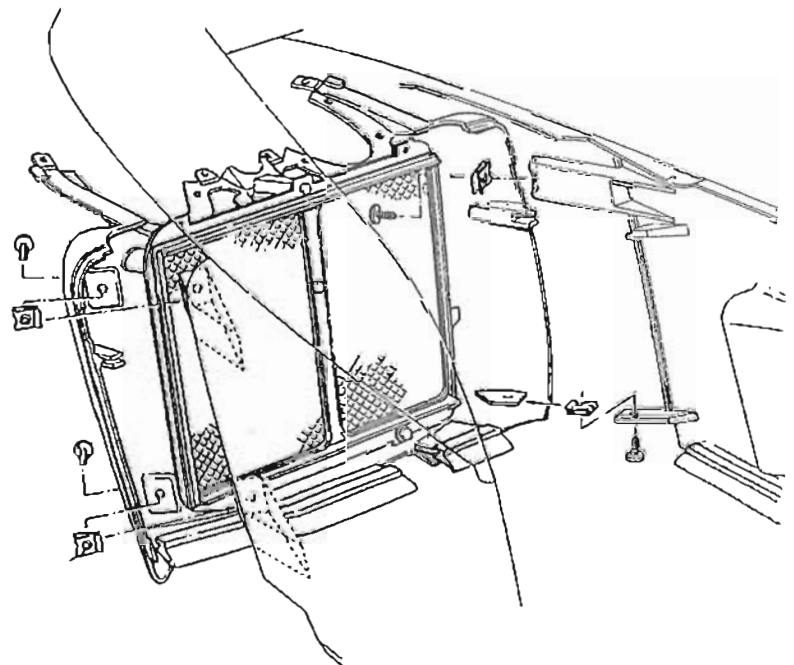
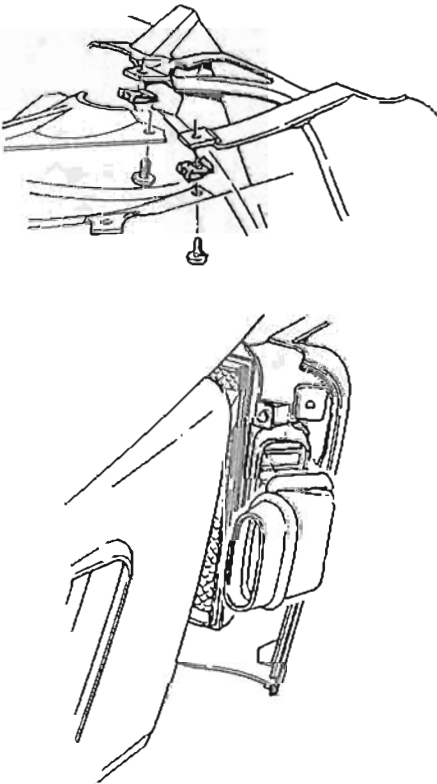

Windshield and Inner fairing – removing and installing

Remove retaining screws for windshield and inner fairing on either side (arrow).

Remove retaining screws on windshield (arrows).
Take off windshield and reinforcing plate.

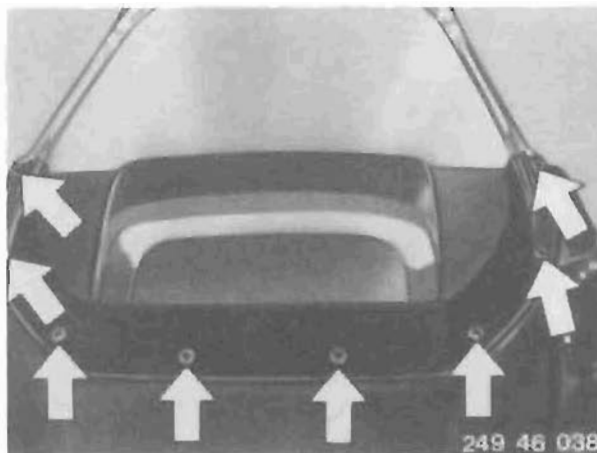

Pull back inner cover in the direction of the arrow and take off.

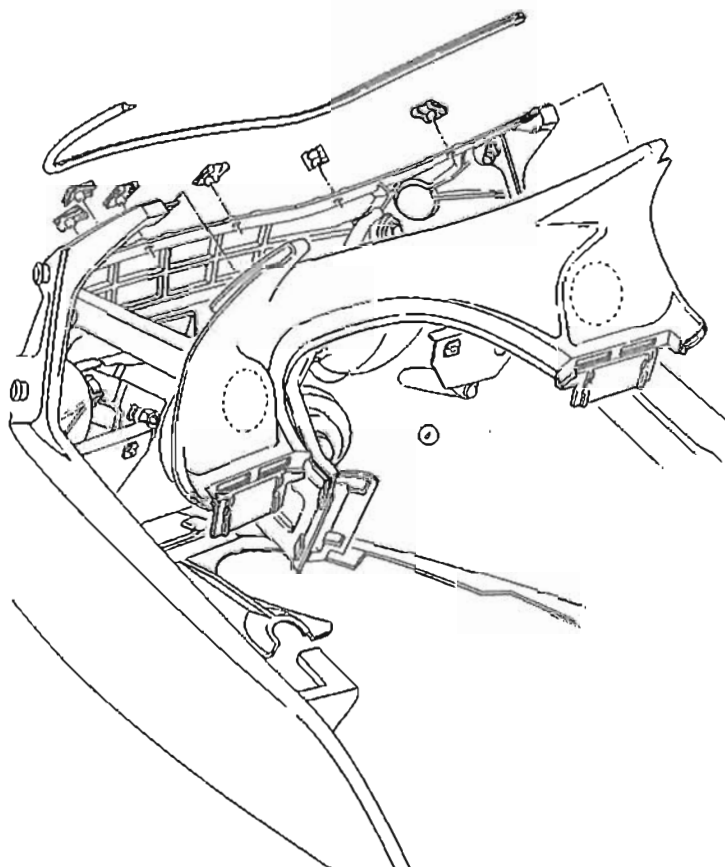
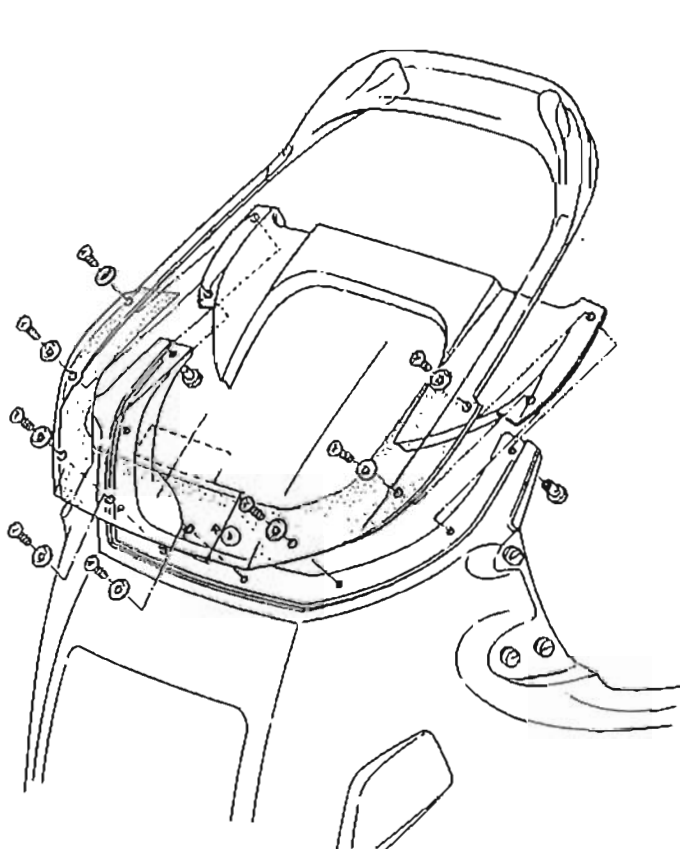
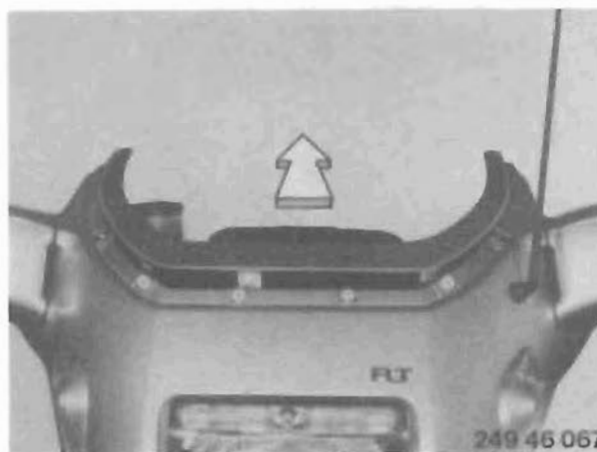

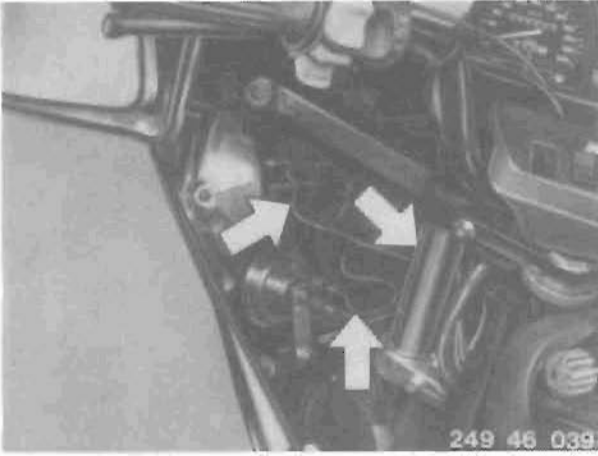

Upper fairing – removing and installing

Pull electric cables off turn indicators and horn (arrows) on either side, and pull off headlight cables.

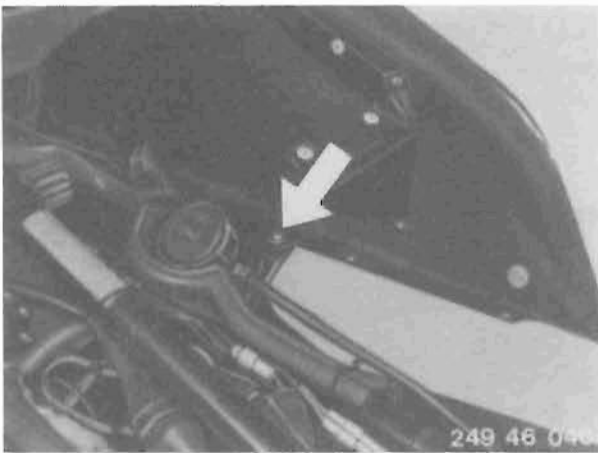

Remove side retaining screws on upper section of cockpit on either side (arrow).

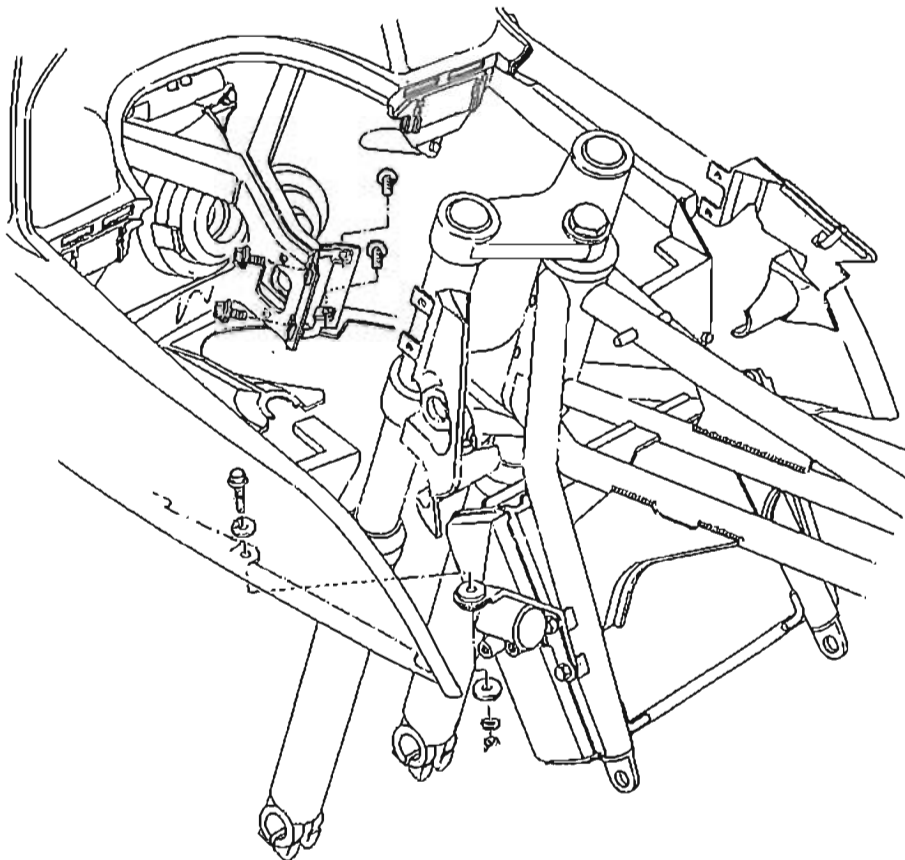

Remove retaining screws on fairing mounting (arrows) on left and right.
Take off fairing.



Fairing mounting – removing and installing

Remove retaining screws (arrows) on either side and take off the plastic covers on either side.

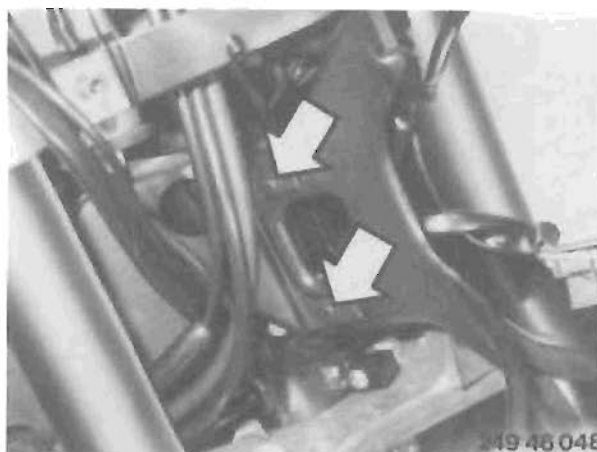

Disconnect the cable straps (arrows) on the fairing mounting.
Remove the retaining screws (arrows) on either side.
Take off the fairing mounting on either side.

Install following the same procedure but in the reverse order.

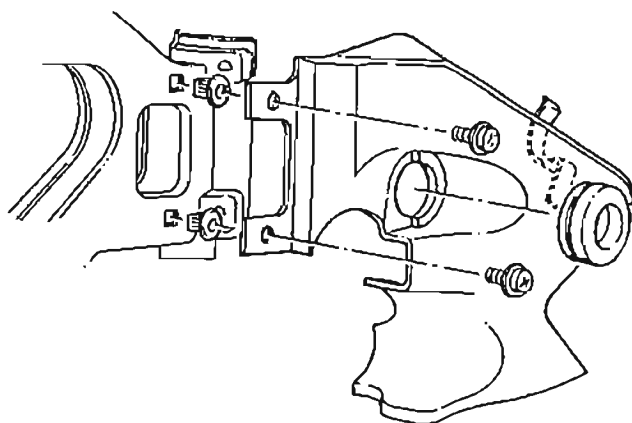
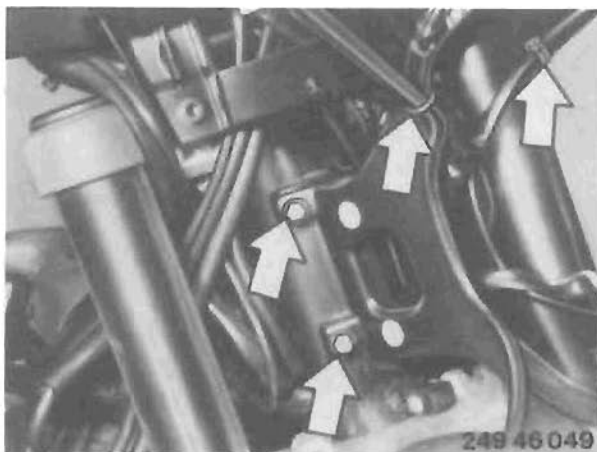

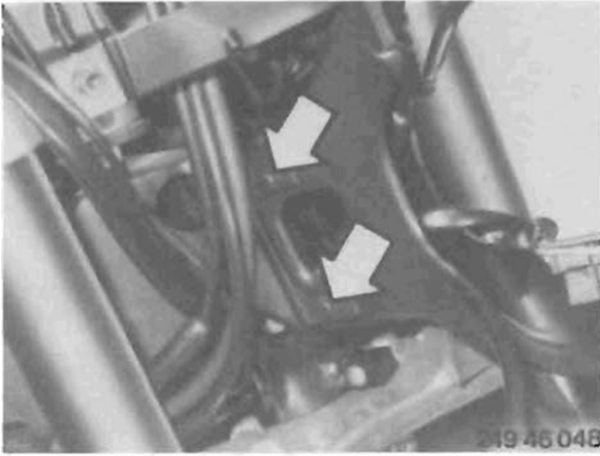

Frame – removing

Removing fairing for K 100 RS, RT, LT, K 75 s: see page 46–01.0.

Removing fuel tank: see page 16–01.0.

Remove battery earth lead and isolate cable.

K 100 RS, RT

Remove retaining screws for steering head cover (arrows) on either side.

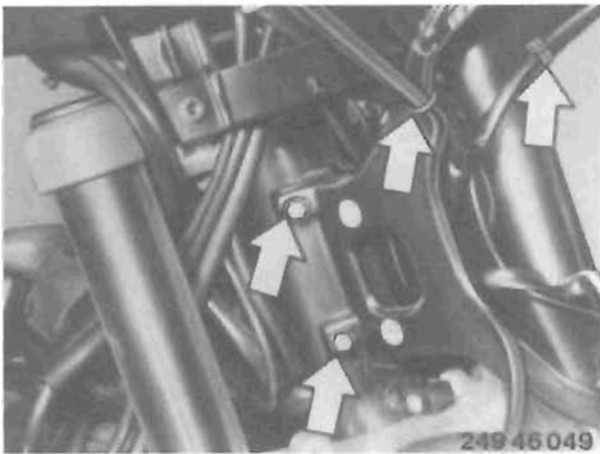

K 100 RS, RT

Remove cable straps for turn indicator cables on fairing mounting.

 +  with fairing

Remove retaining screws (arrows) for fairing mounting on either side.

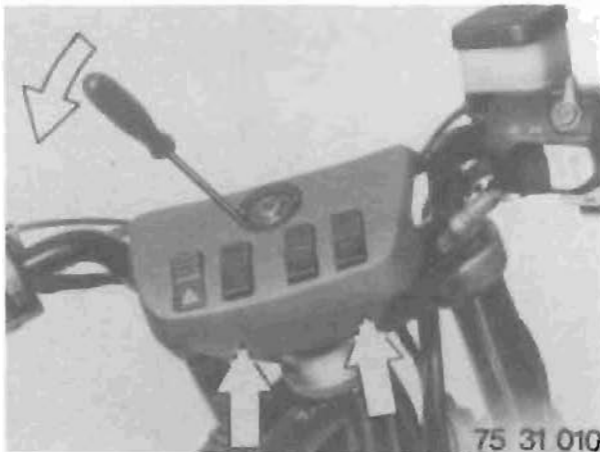

Remove handlebar and fittings.

Lever out marker disc for ignition lock with a small screwdriver.

Push in ignition lock retaining hook with a small screwdriver and pull down the ignition lock to remove. Remove retaining screws (arrows) and take off impact plate.

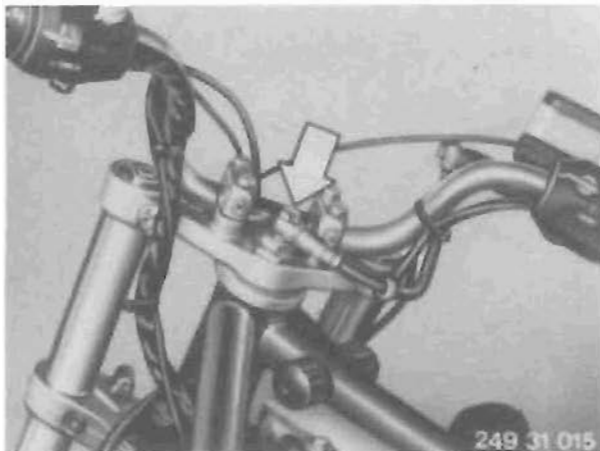

Remove hollow screw (arrow) for securing brake line to distributor pipe.

Note:

Stop up brake line with screw and seal rings.

Brake fluid attacks paintwork

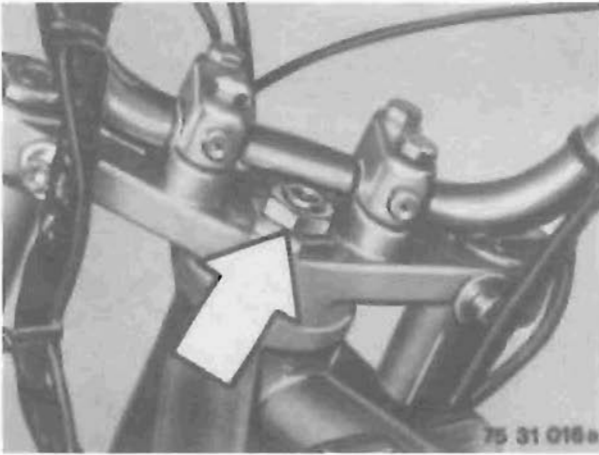

Remove plastic nut (arrow) on distributor pipe and pull down distributor pipe to remove.

Note:

Stop up the distributor pipe.

Brake fluid attacks paintwork

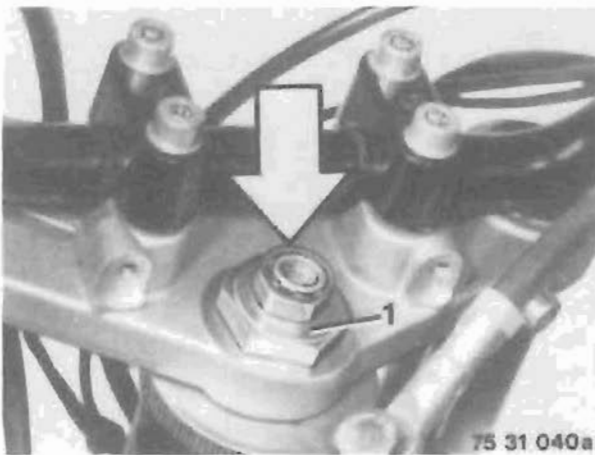

Remove clamp (arrow) on distributor pipe and pull down distributor pipe.

Note:

Stop up the distributor pipe.

Brake fluid attacks paintwork

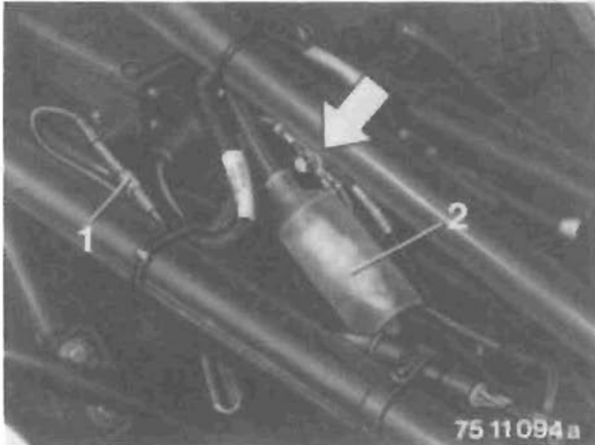

Disconnect clutch cable at withdrawer arm on gearbox and pull out as far as the handlebar.

Disconnect the clutch switch (1) and left fitting (2), and pull out the leads as far as the handlebar.

Remove retaining screw (arrow) for central earth on frame.



Slacken off wire cable for increased starting speed at the throttle butterfly switch.

Remove the locking nut (1) and screw the adjusting screw (2) fully in.

Lever off the cap on the choke lever and remove the visible slotted screw.

Take off the lever and disconnect the wire cable.

Disconnect the cables for brake light switch (1) and leads for the right-hand fitting (2).

Disconnecting the throttle cable at the throttle butterfly system:

Push in the cam plate and disconnect the wire cable.
Disconnect the Bowden sleeve at the reaction bearing.

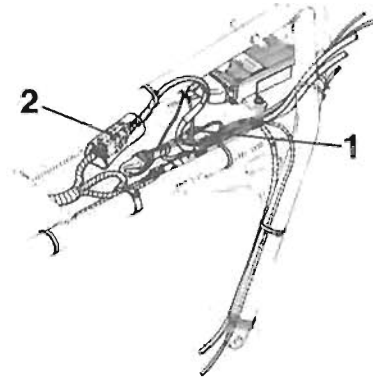

249 46 069

Remove retaining screws (arrows) for handlebar clamp blocks and take off complete handlebar together with fittings.

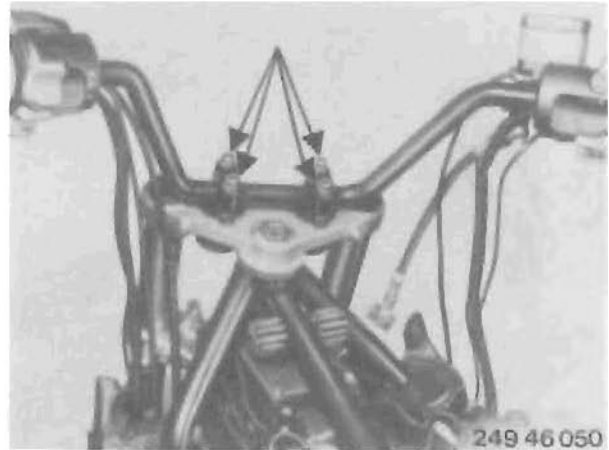

249 46 050

Telescopic fork with front wheel – removing



Slacken off the retaining screws (arrows), remove hex nut (1) and pull off upper fork bridge.

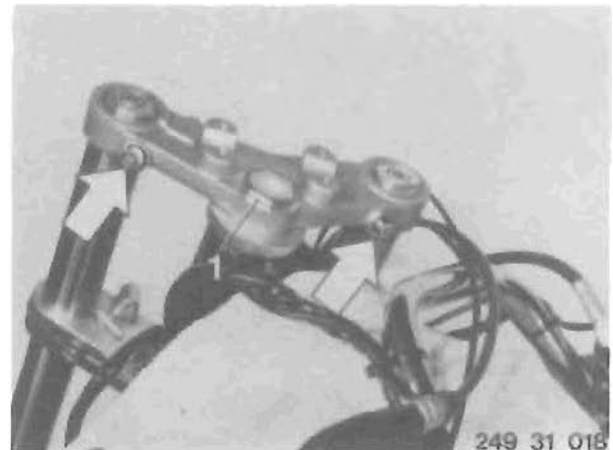

249 31 018



Slacken off retaining screws (arrows), remove stop screw (1) and pull off upper fork bridge.

Unscrew adjusting ring on steering head tube.

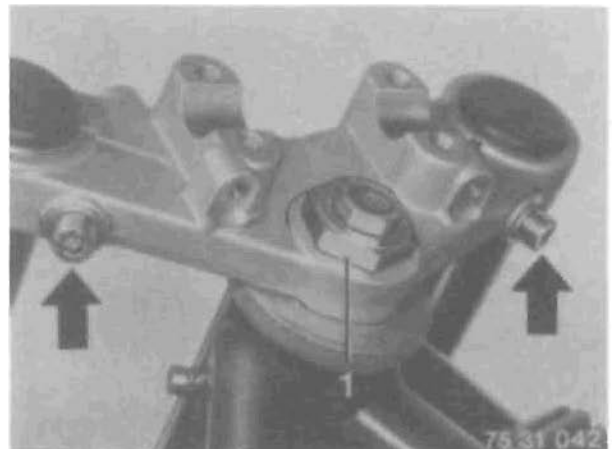

75 31 042



Tap the telescopic fork several times with a plastic mallet to push down until the upper bearing is exposed, and take out the bearing.

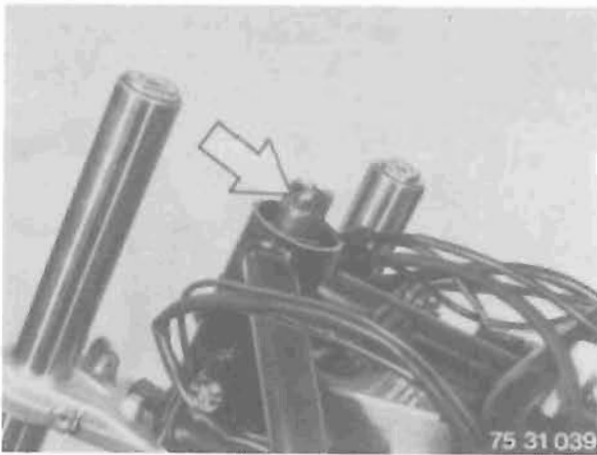

K 75 c with cylindrical steering head tube

To avoid damage to the fluidbloc cover over the thread on the steering head tube with 1 1/2 layers of adhesive tape.

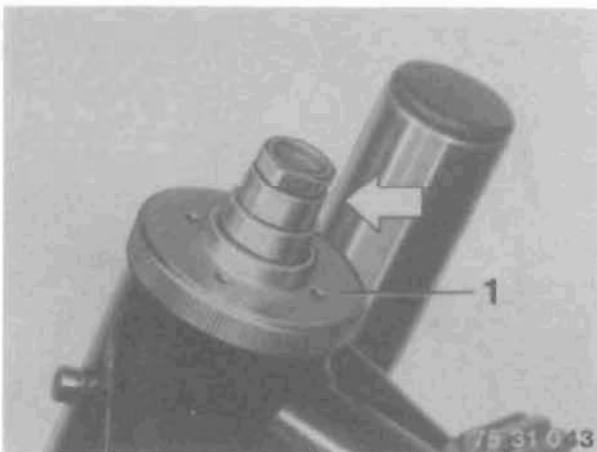

Secure locking tube (arrow), unscrew adjusting ring (1) and taper roller bearings on steering head tube.

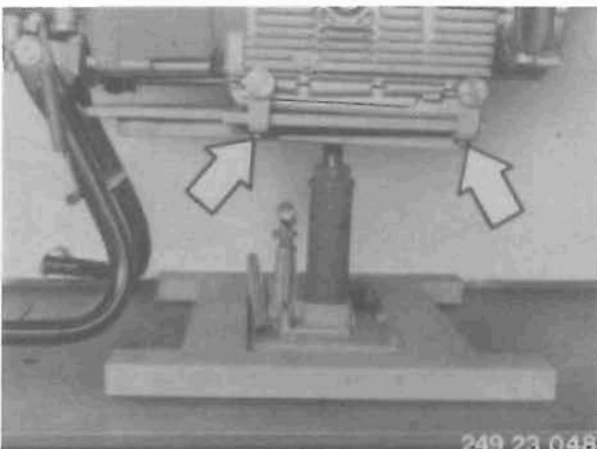

Secure BMW hoist 00 1 510 to the oil sump with 4 knurled screws.

Tighten the retaining screws (arrows).

Raise the engine until the front wheel clears the ground.

Pull telescopic fork together with front wheel out of steering head tube.

Note:

Support the distributor pipe to prevent it from falling.

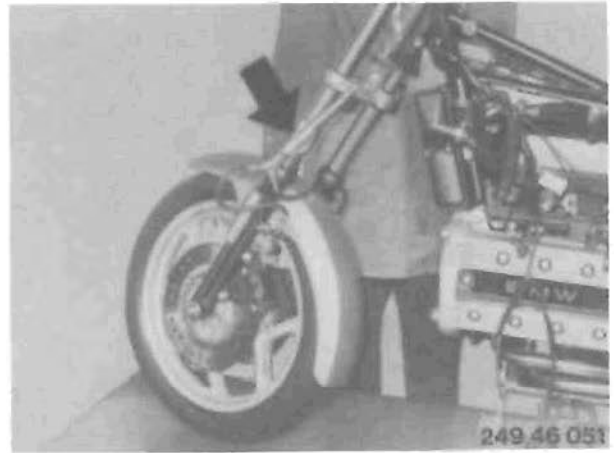

Radiator – removing

Remove stop screw (arrow) on water pump and drain off coolant.

Note:

Slacken off filler pipe cap to speed up draining process.

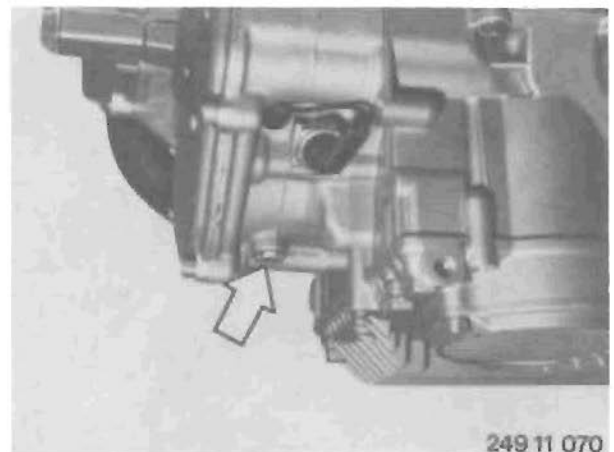

Pull air intake line out of lower section of air cleaner housing and pull off intake pipe.



Remove retaining screws (arrows) on frame for coolant filler pipe and overflow (1). Detach both coolant hoses at base (2, 3).

Note:

Stop up overflow.

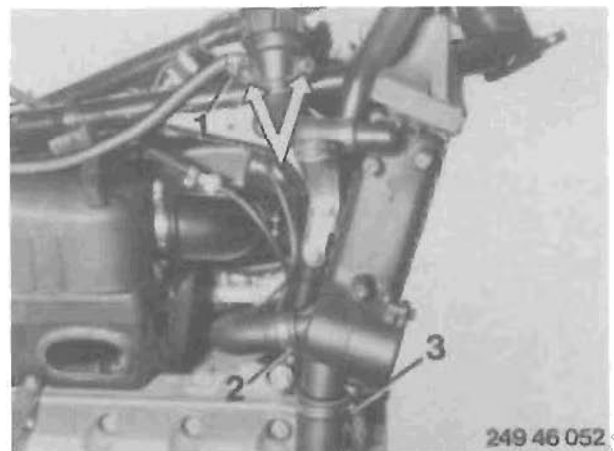

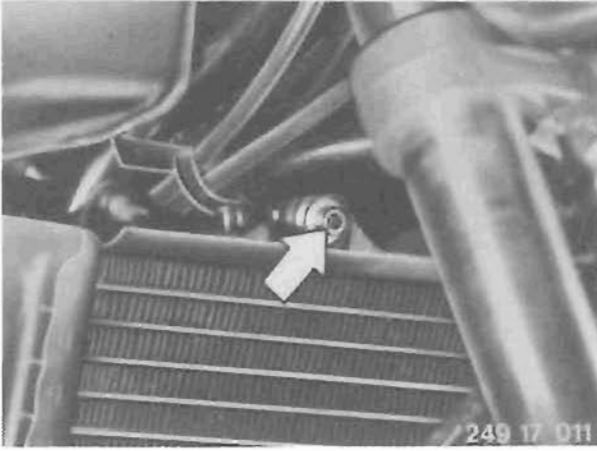

Remove retaining screw (arrow) on frame for radiator.
Tilt radiator up at front, disconnect plug on fan motor and
take out the radiator to the front.

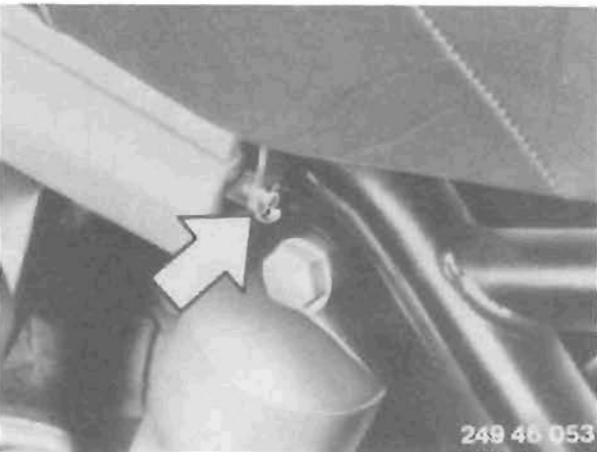

Dualseat – removing
Pull circlip (arrow) off pin on frame.

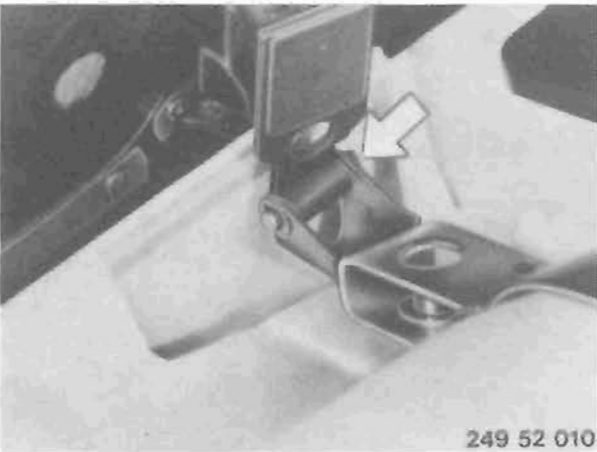

Fold up dualseat, remove retainer (arrow) on dualseat
hinge and pull out pin.



Remove retainer (arrow) from base of dualseat support.
Take off dualseat.

Rear section with rear mudguard – removing

Remove retaining screws (arrows) on licence plate holder, remove retaining nuts in storage compartment. Pull out the licence plate holder.

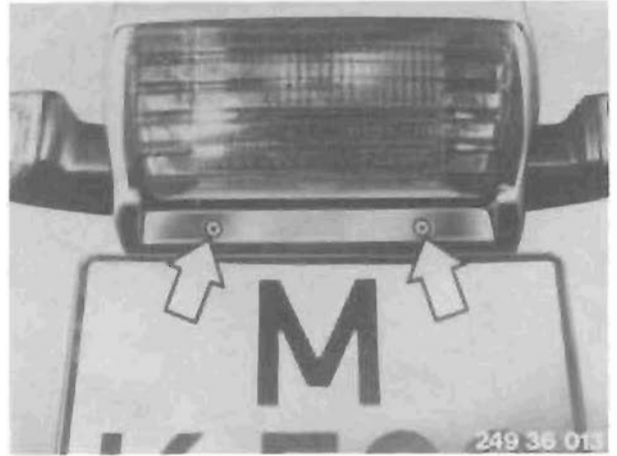

Remove the retaining screws (arrows) in the storage compartment. Take off the rear light cluster to the rear. Pull the multi-pin plug of the rear wiring harness out of the plug socket.

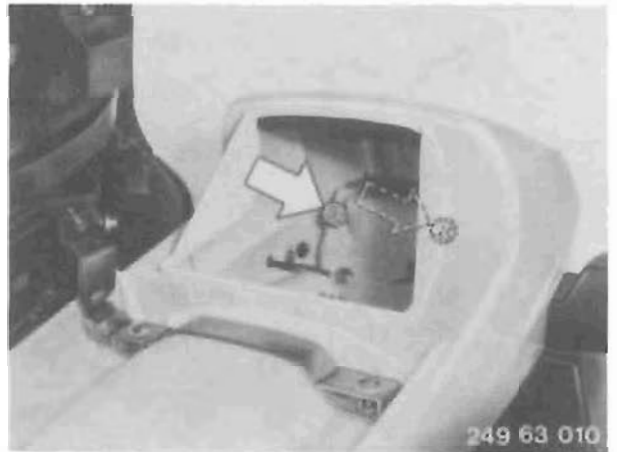

Remove the two recessed-head screws and two Allen screws on the bridge (arrows). Remove the complete rear section. Note the rubber discs.

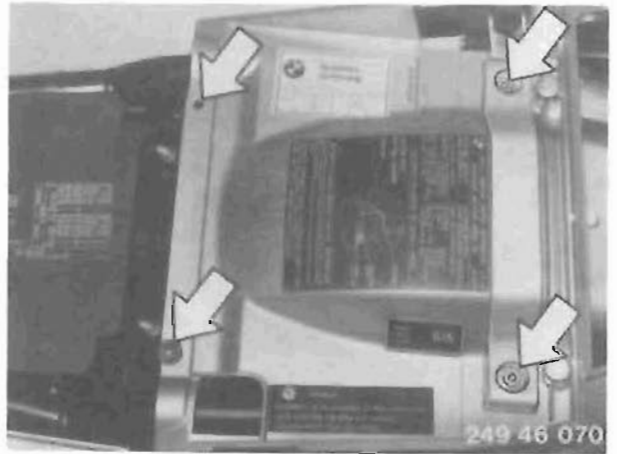

Remove the two last retaining screws for the rear mudguard (arrows) and take off the mudguard.

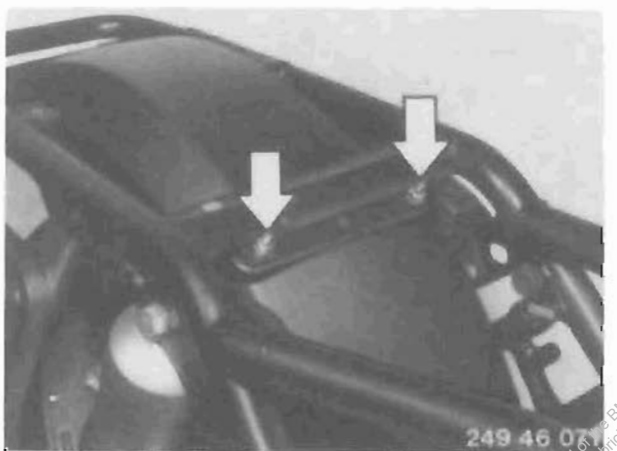

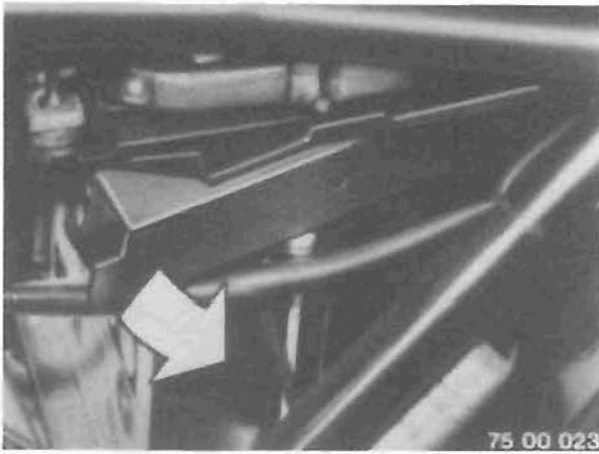

Fuel injection control unit – removing

Pull off cover for fuel injection control unit in the direction of the arrow.

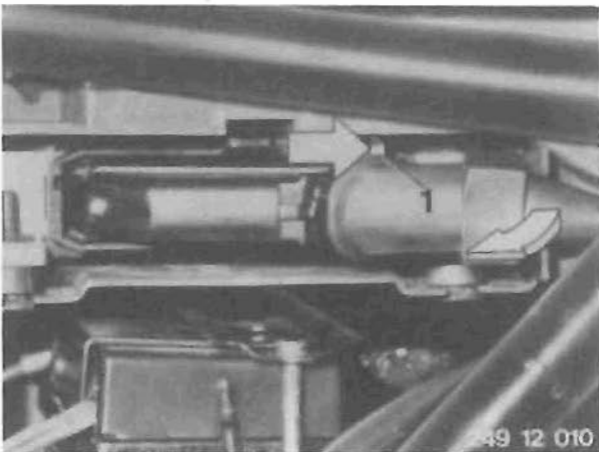

Push retaining loop back from multi-pin plug in the direction of arrow.

First pull the multi-pin plug back, then disengage at the front.



Lever out the storage compartment complete with fuel injection control unit.

Remove frame mounting at cylinder head and gearbox (at ignition coil end).

Electrical connections – disconnecting

Disconnect plug for engine wiring harness (arrow).
Disconnect cable strap for engine wiring harness.

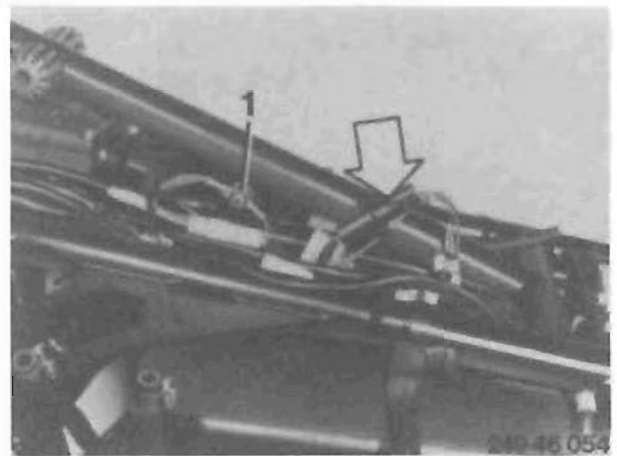

Disconnect cables:

- Disconnect battery positive lead
- Disconnect positive lead (arrow) at starter motor
- Disconnect engine/frame wiring harness plug connection.

Disconnect plug for Hall-effect transmitter (1) and oil pressure switch (2).

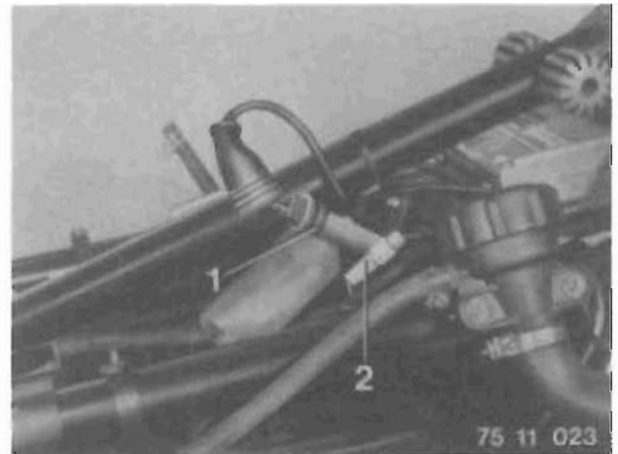

Disconnect plugs at rear right of frame:

- Speedometer plug (flat)
- Brake light switch plug (flat)
- Gear indicator plug (round)

Release all cable straps.

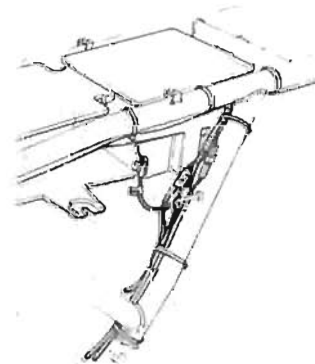

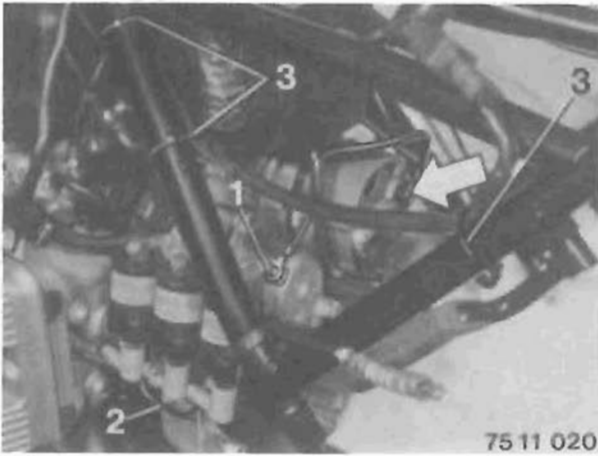

Pull plug (arrow) off alternator.

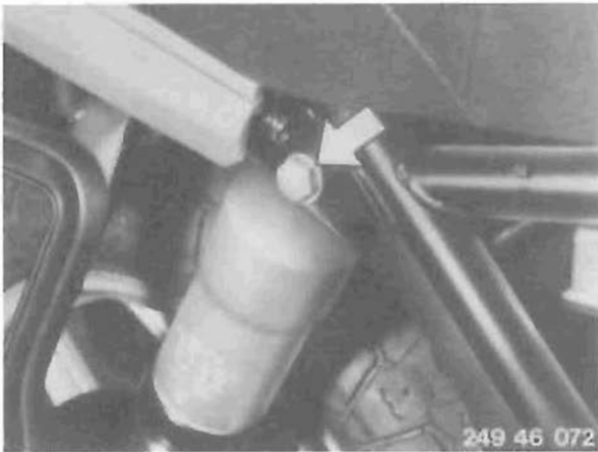

Frame – disconnecting from driveline

Remove frame retaining screws (arrow) at top of spring strut, on gearbox, intermediate flange and engine.

Note:

Note shims.

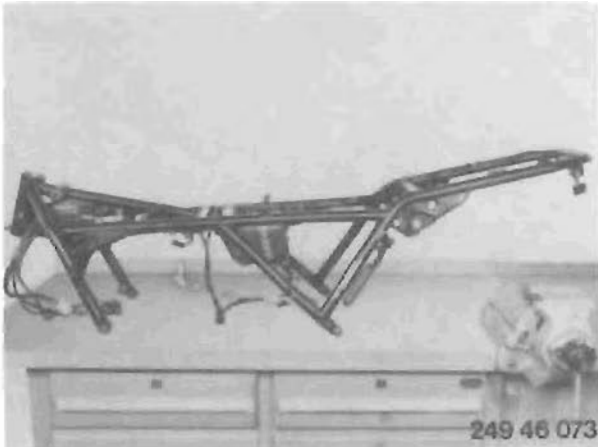

Remove battery mounting on right, pull out header tank and secure to the engine with wire.

Lift frame off drive unit and set down on workbench.



Steering lock – removing

Break plastic cover on steering lock and remove.

Lever notched pin out of frame with side cutter.

Lever metal cover off steering lock with a screwdriver.

Turn the steering lock with the key and pull out.

Ignition control unit – removing

Push back protective cap and pull multi-pin plug out of ignition control unit.

Warning:

Do not tilt, otherwise contacts may become bent.

Remove retaining screws (arrows) on left and right.

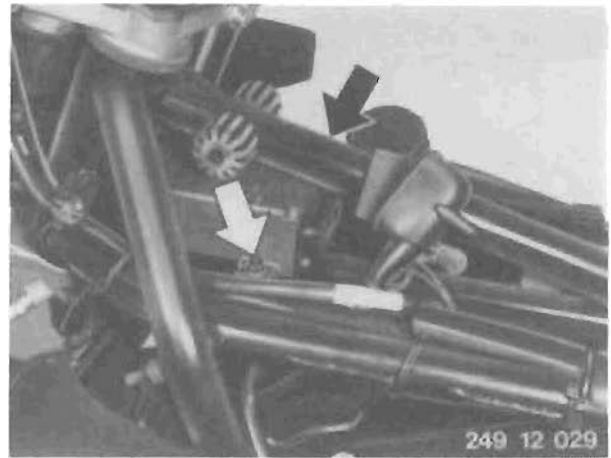

Push back the ignition control unit until the lug (arrow) projects completely out of the steering head. Take out the ignition control unit to the right or left.

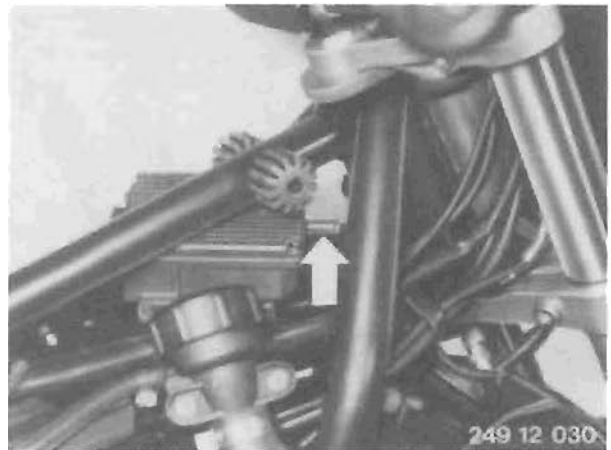

Frame wiring harness – removing

Disconnect all cable straps, pull out all fuses and take out the central electrical equipment box together with wiring harness.

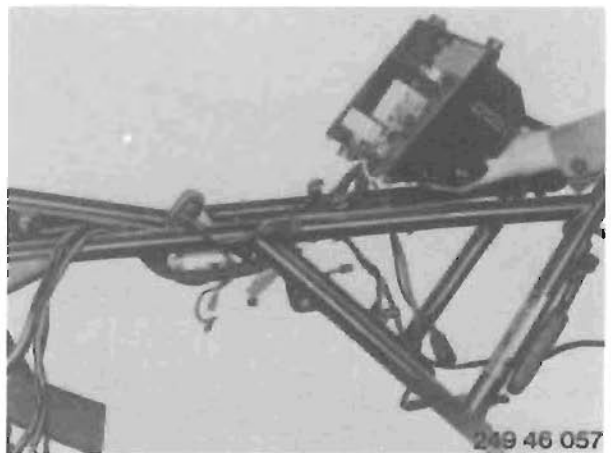

Dualseat lock – removing

Remove retaining screws (1, 2) for dualseat lock and take off lock.



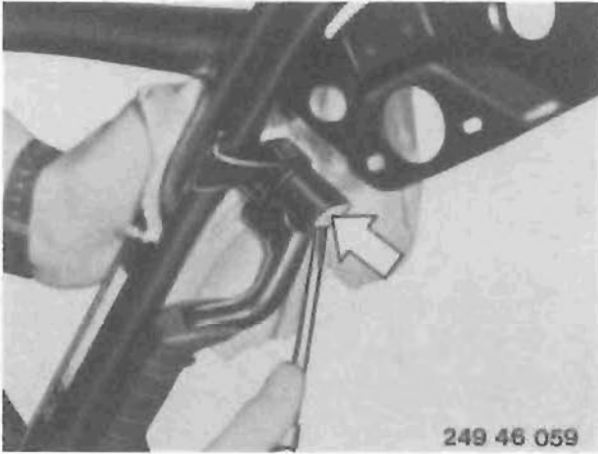

Grab handle – removing

Lever out the spring bearing (arrow) on the grab handle with a screwdriver.

Pull spring bearing off spring.

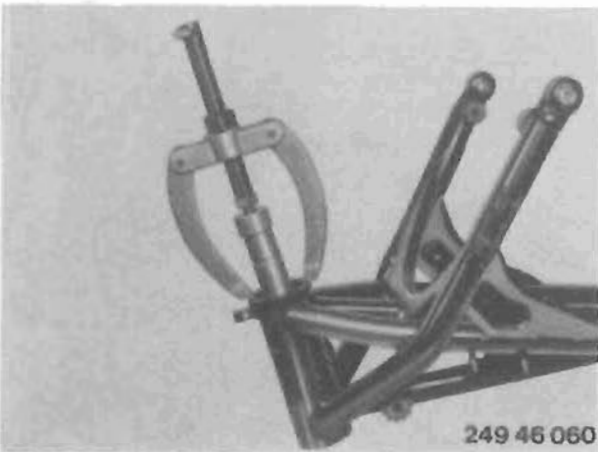

Bearing shells for steering head bearing – removing

Pull out steering head bearing outer race with Kukko puller, BMW 00 5 560, together with BMW support ring 31 4 800.

Note:

Do not mix up the upper and lower bearing shells.

Rubber bearing on frame – removing

Pull all rubber bearings off frame.

Remove rubber support for fuel tank at front and rear,
 rubber bearing for ignition control unit,
 rubber bearing for radiator,
 rubber bearing for central electrical equipment box and
 box for fuel injection control unit,
 rubber bearing for battery covers and
 all sheet metal nuts and cage nuts in rear frame section.



Remove taper screws on left and right of steering head and take out fluidbloc.

Frame – Installing

●●● Fluidbloc – Installing

Fill chambers in fluidbloc (1) with silicone grease and push into steering head (2) until screw imprints appear in both upper threaded holes. Screw in the taper screws (3).

Note:

Only use grade 300 silicone grease; other lubricants will alter the precisely specified frictional values.

Tightening torque:

Taper screws

$9 \pm 1 \text{ Nm}$

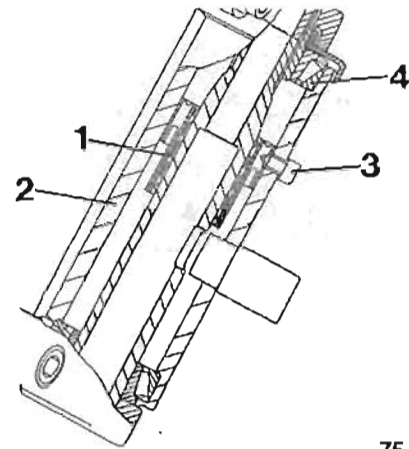

75 31 044

Bearing shells for steering head bearing – installing

Completely push in bearing outer races for taper roller bearing with feeler gauge spindle (1), BMW spacer 31 4 820 (2) with washer and hex nut (3).

Do not mix up the upper and lower bearing outer races.

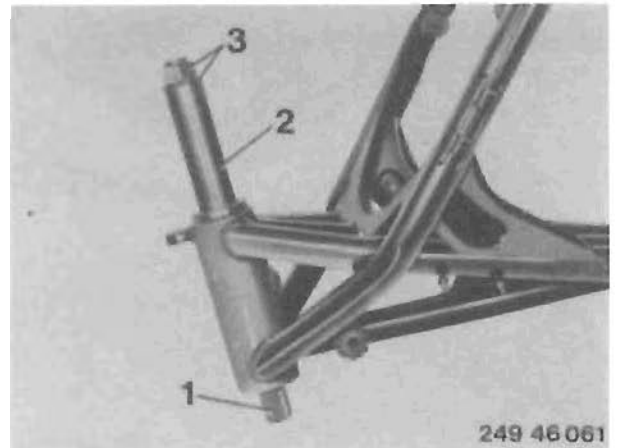

249 46 061

Affix the sheet metal and cage nuts and fit the rubber bearing.

Rubber bearings for:

Ignition control unit, radiator, central electrical equipment box, box for fuel injection control unit, battery trims and fuel tank at front (only at rear with plug-mounted fuel tank).

Front silentblocs – pressing in

K 100 RS, RT, LT

Press silentblocs in at front.

(1) M 10 × 140 screw with nut and long threaded piece.

(2) 13 mm socket wrench insert

(3) 22 mm socket wrench insert, 1/2" drive

When installing:

Apply lubricant (tyre mounting paste) before pressing in.

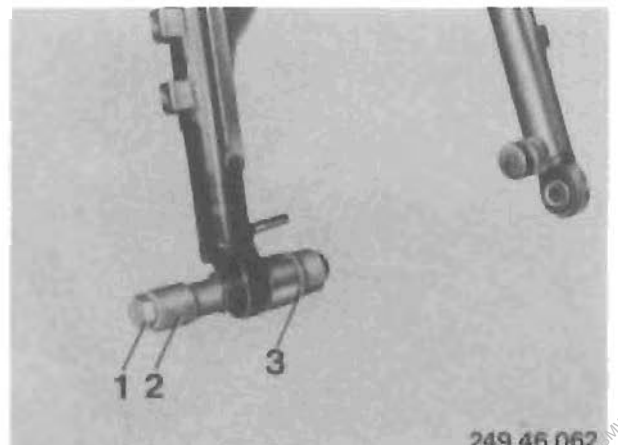

249 46 062

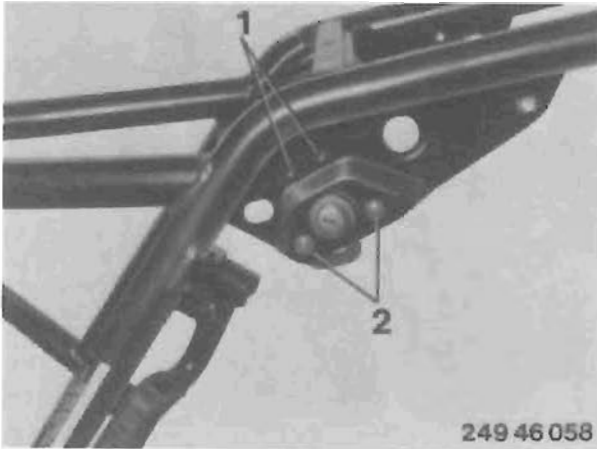

Dualseat lock – installing

Push dualseat lock into gusset plate and secure with recessed-head screws at top, then insert lock screws at base and tighten.

Steering lock – installing

Turn steering lock with key and insert. Secure cover with notched pin.



Lift handle – installing

Fit lift handle to greased tube on frame. Grease spring and push into tube with upper spring bearing. Push out spring with screwdriver until the lower spring bearing can be engaged.

Note:

The spring bearings must engage in grooves.

K 100 RS, RT, LT and K 75 s

Drive notched pins for steering lock limiting into the welded-on stop on the steering head.

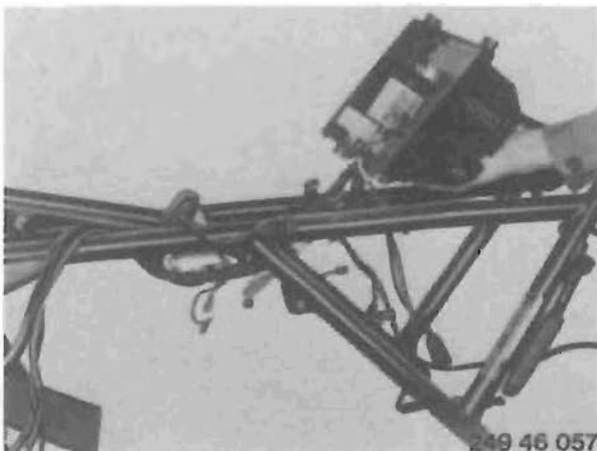

Frame wiring harness – installing

Install box for central electrical equipment together with wiring harness, and insert fuses.

Run the wiring harness from the centre to the front and rear, according to model.

Note the positions of cable straps.

Warning:

When installing the wiring harness, it is essential to avoid kinks and points where abrasion could occur.

Do not allow plug connections to make contact with the frame.

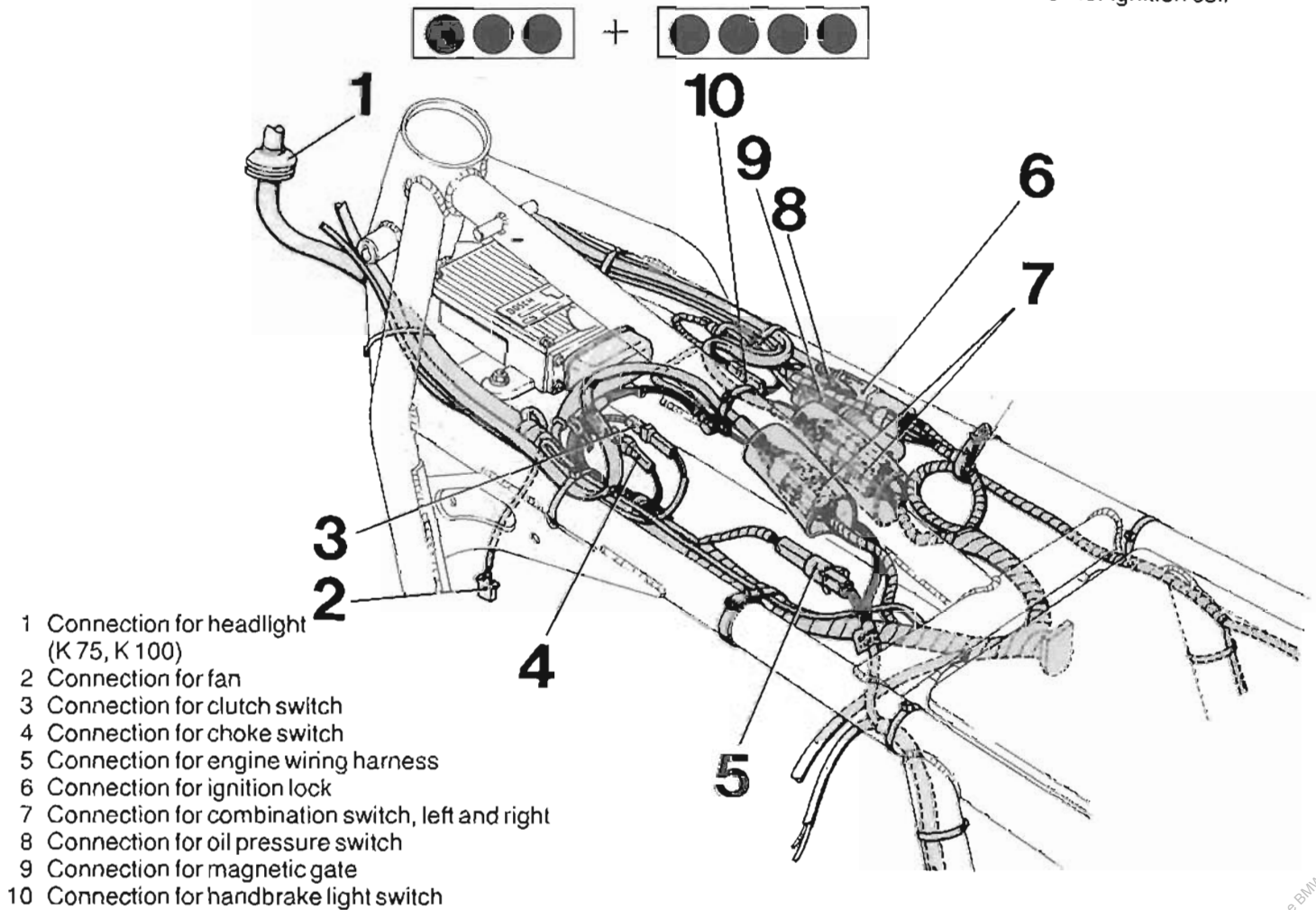
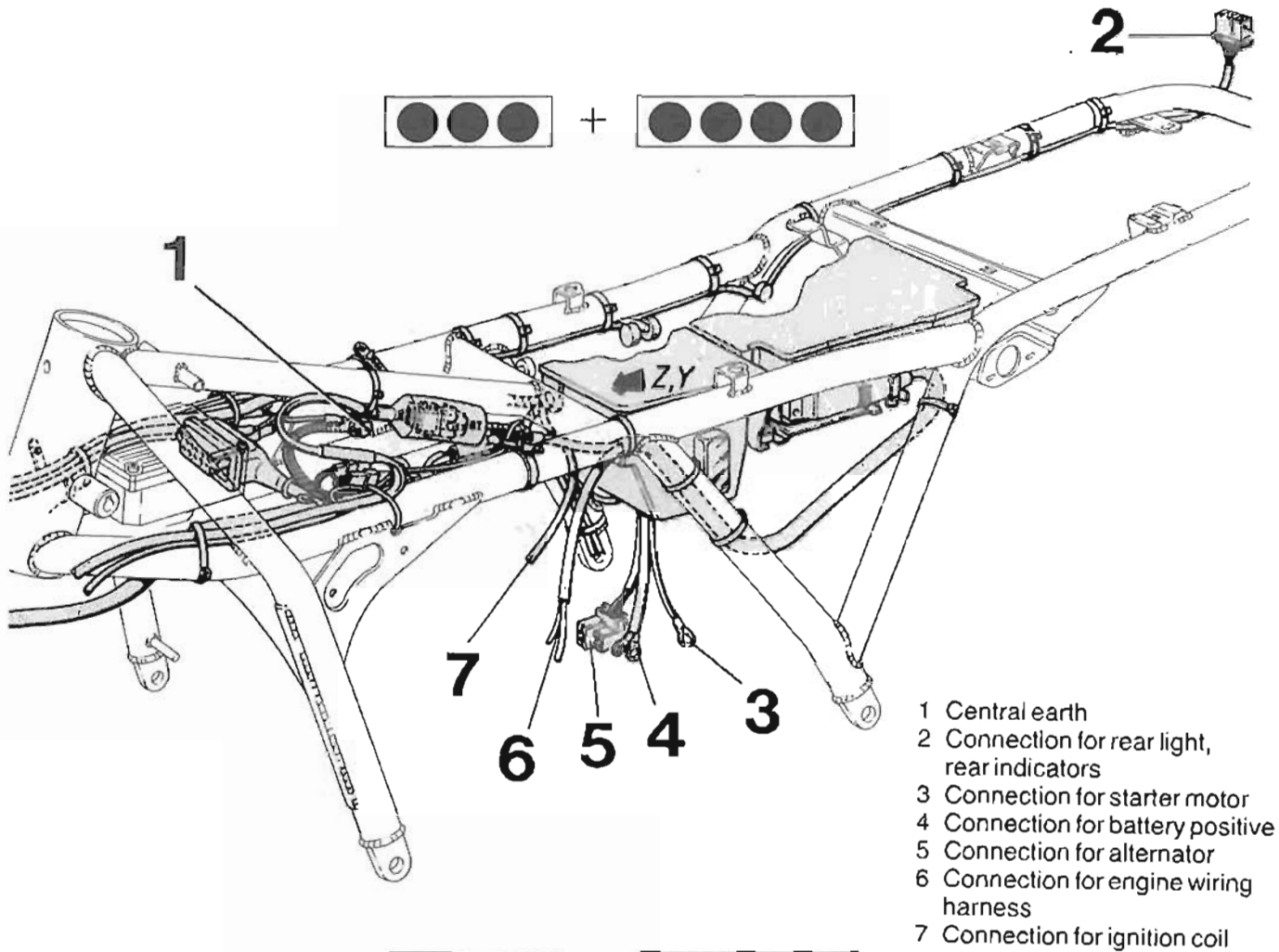

K 100

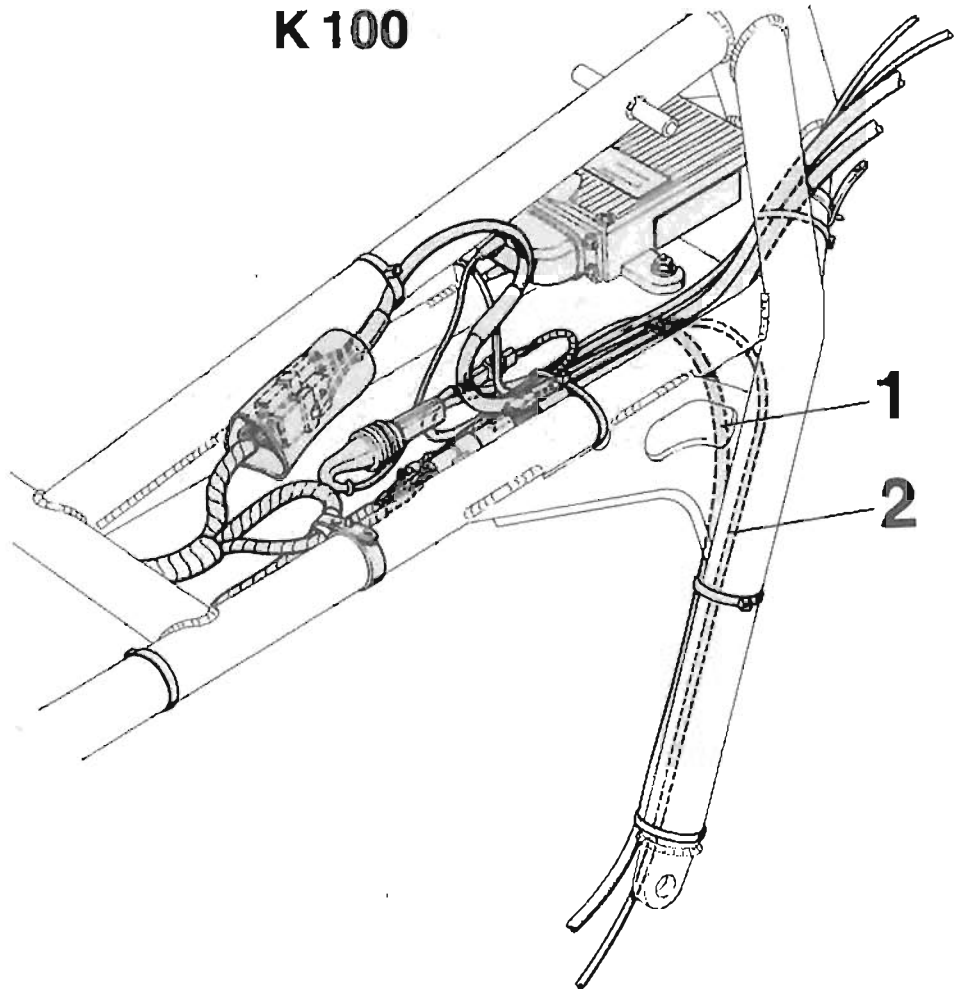

- 1 Magnetic gate wire
- 2 Oil pressure switch wire

K 100 RS, RT

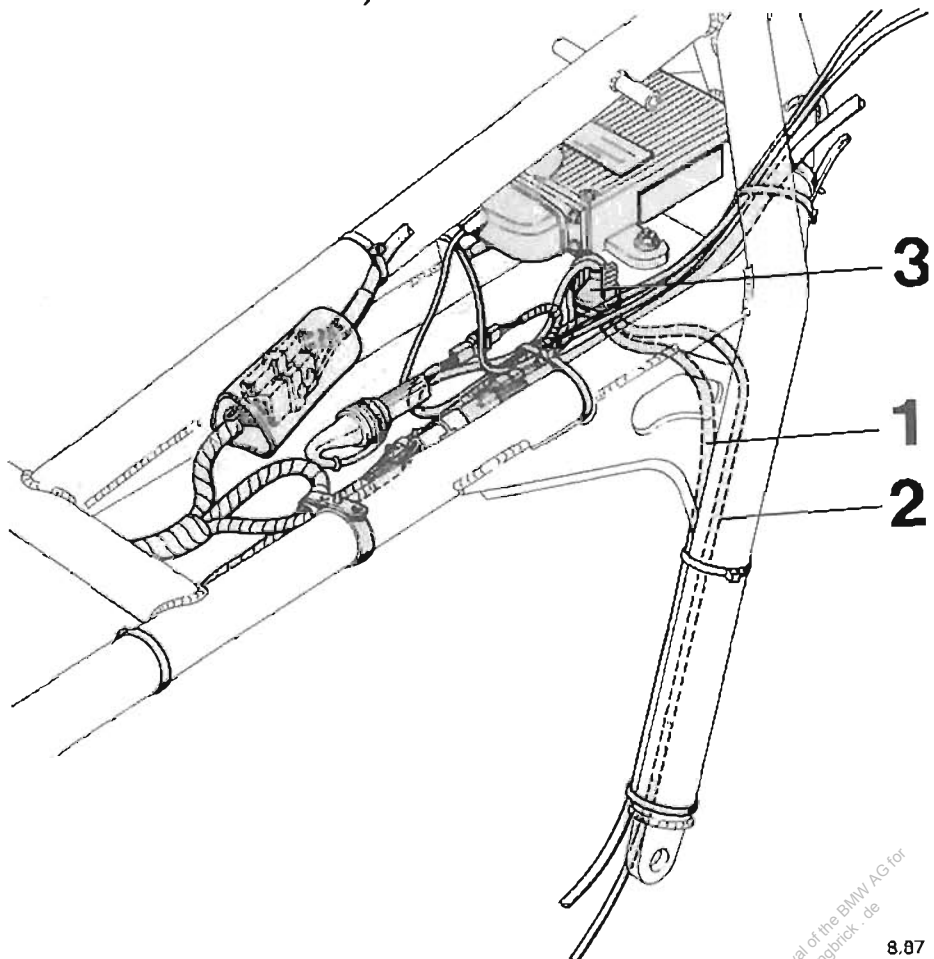

- 1 Magnetic gate wire
- 2 Oil pressure switch wire
- 3 Passage in divider

K 100 RS, RT

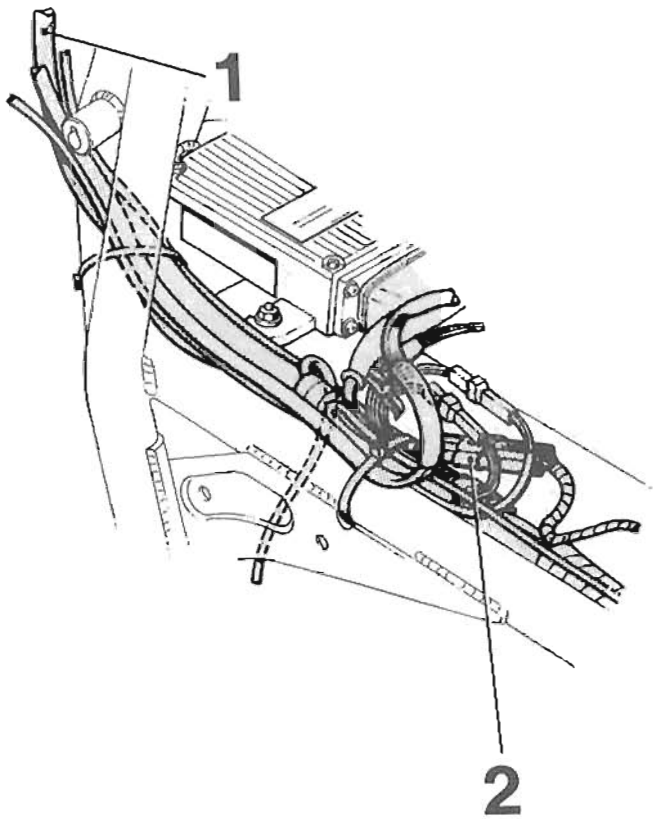

- 1 Connection for headlight/
instrument cluster
- 2 Connecting lead to fairing
(round 5-pin plug housing)

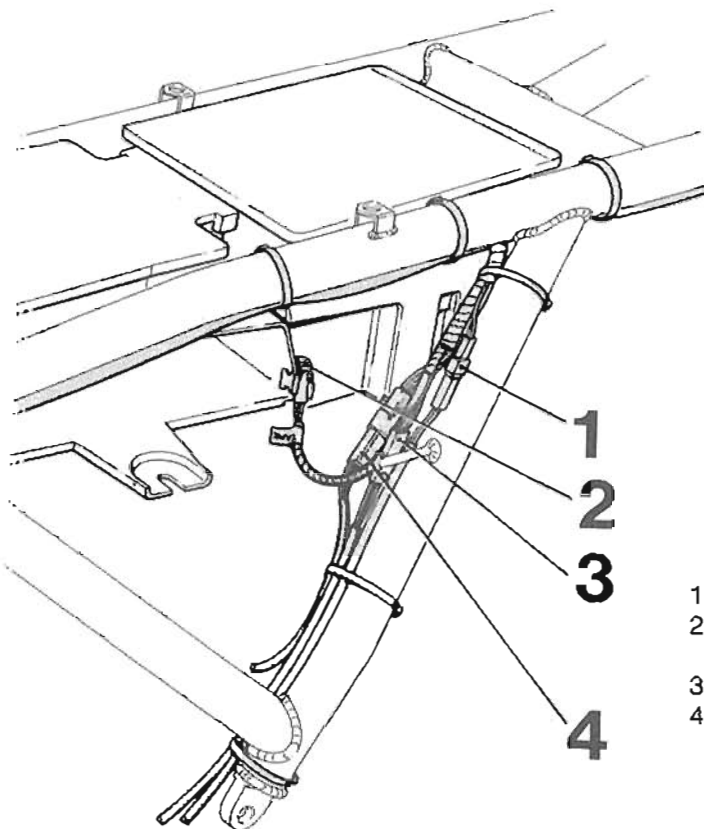
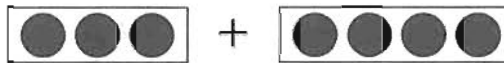

- 1 Connection for footbrake light switch
- 2 Connection for fuel level sensor
(lever sensor and fuel pump)
- 3 Connection for inductive sensor
- 4 Connection for gear indicator

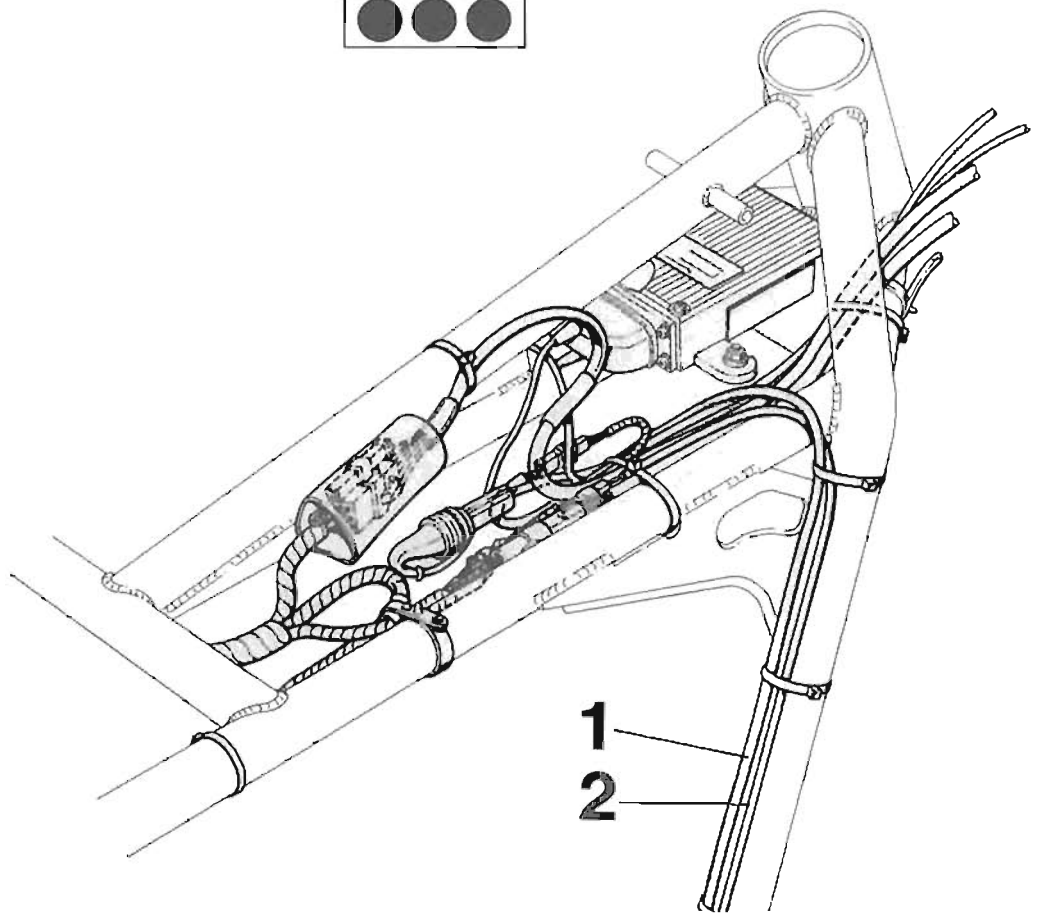

- 1 Magnetic gate wire
- 2 Oil pressure switch wire

K 75 s

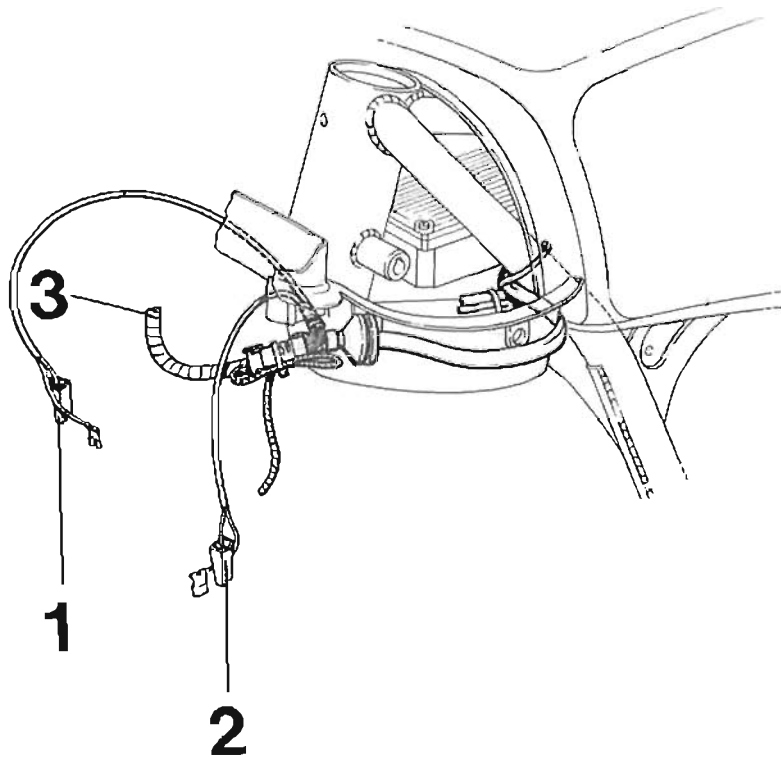

- 1 Right-hand indicator
- 2 Left-hand indicator
- 3 Headlights

46-66.0

Frame – fitting to driveline

and screwing tight according to model:

K 100 (bridge-mounted fuel tank)

Insert screws 1 and 2, and tighten.

Insert screw 3 and tighten.

insert screws 4 and 5 and tighten.

Tightening torque:

Frame to driveline 45 – 6 Nm

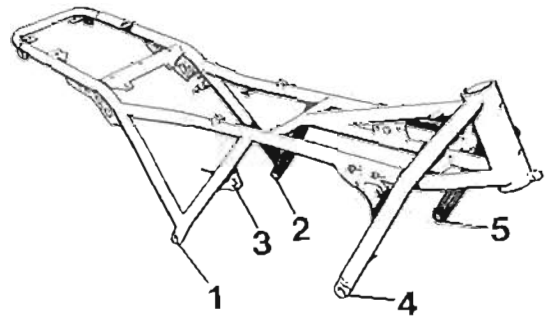

249 46 064

K 100 RS, RT (bridge-mounted fuel tank)

Insert screws 1, 2 and 3 and tighten.

Calculate gap between engine and frame for 4 and 5, and shim out.

Remaining gap must not exceed 0.25 mm.

Insert screws and tighten.

Tightening torque:

Frame to driveline 45 – 6 Nm

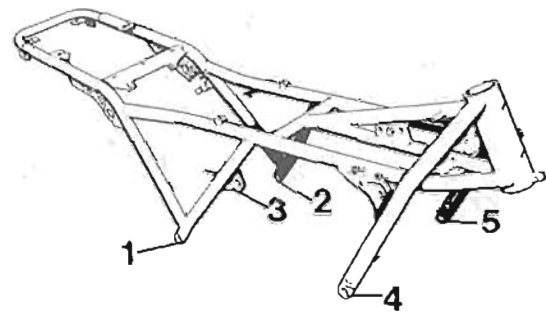

249 46 065

K 100, K 75 c, s (plug-mounted fuel tank)

Insert screws 1, 2 and 4, and tighten 1 and 2.

Calculate gap between frame and eye on intermediate flange and shim out.

Remaining gap must not exceed 0.25.

Insert screw 3 and tighten.

Insert screw 5, and tighten 4 and 5.

Tightening torque:

Frame to driveline 45 – 6 Nm

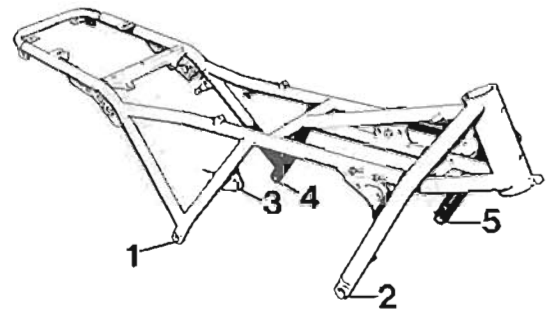

249 46 066

K 100 RS, RT (plug-mounted fuel tank)

Insert screws 1, 2 and 4, and tighten 1 and 2.

Calculate gap between frame and eye on intermediate flange and shim out.

Remaining gap must not exceed 0.25. Insert screw 3 and tighten, tighten screw 4. Calculate gap between engine and frame at 5 and shim out.

Insert screw 5 and tighten.

Tightening torque:

Frame to driveline 45 – 6 Nm

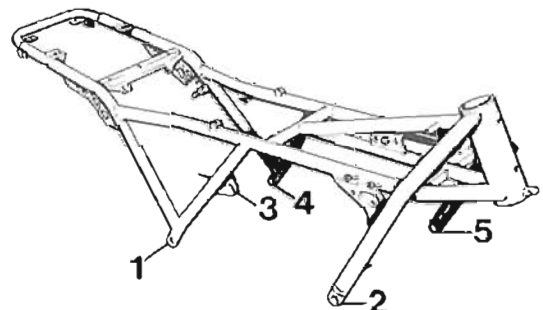

249 46 067

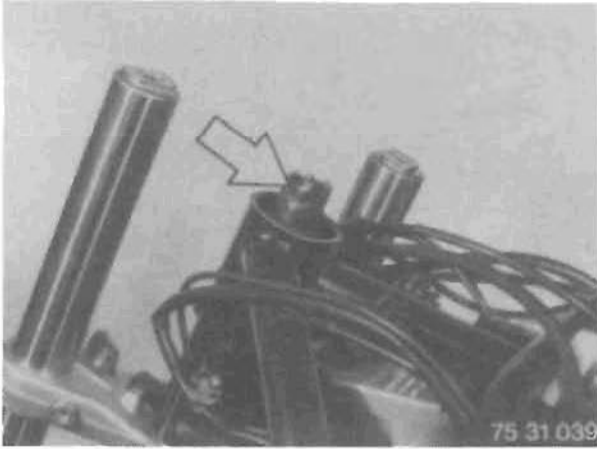

Telescopic fork – installing

Install the complete telescopic fork in the frame together with front wheel

Lower the engine hoist (with weight on front wheel).

K 75 c with cylindrical steering head tube: mask off thread with 1 1/2 layers of adhesive tape to prevent the fluidbloc from becoming damaged.



Note:

Only fill the fluidbloc chambers with grade 300 silicone grease; other lubricants will alter the specified frictional value.

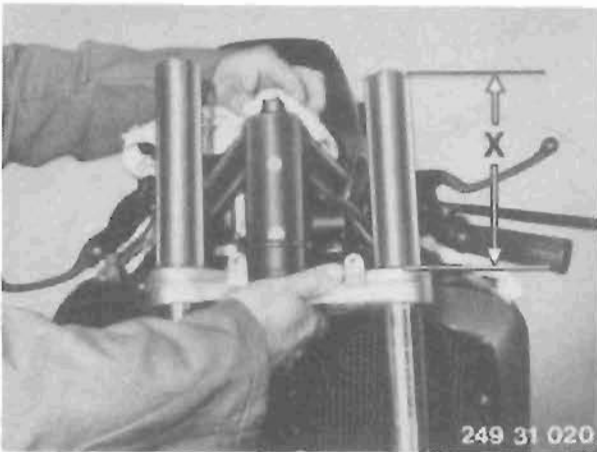

Gently heat up the taper roller bearing to app. 60°C and fit. Eliminate play at the round nut.

Dimension X should be app. 180 mm.

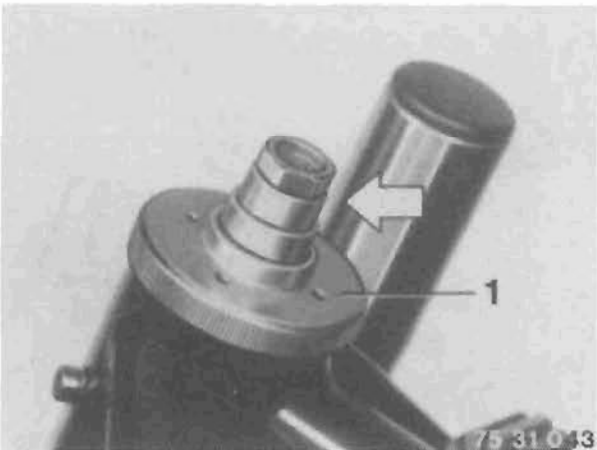

Screw adjusting ring (1) on to steering head tube together with taper roller bearing and locking tube (arrow).

Eliminate adjusting ring play.



Push on upper fork bridge.
Screw in clamping screws (arrows).

When installing:

Fixed tubes must lie flush with the upper fork bridge.
Screw on the stop screw (1).

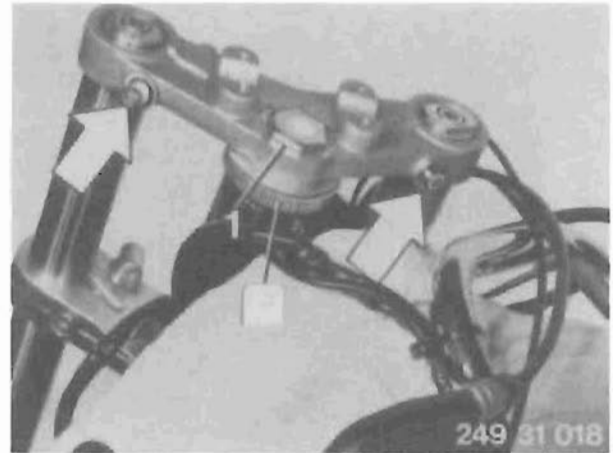

Push on the upper fork bridge, screw in the clamping screws (arrows) and fit the hex nut (1).

When installing:

Fixed tubes must lie flush with the upper fork bridge.

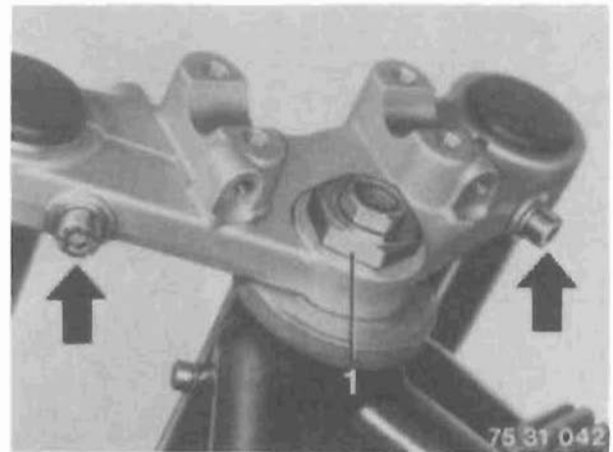

Handlebar

When installing:

The centre-punch mark (arrow) must lie between the two clamping block halves when assembled.

Tighten clamping block retaining screws.

Tightening torque:

Retaining screw 22 ± 2 Nm

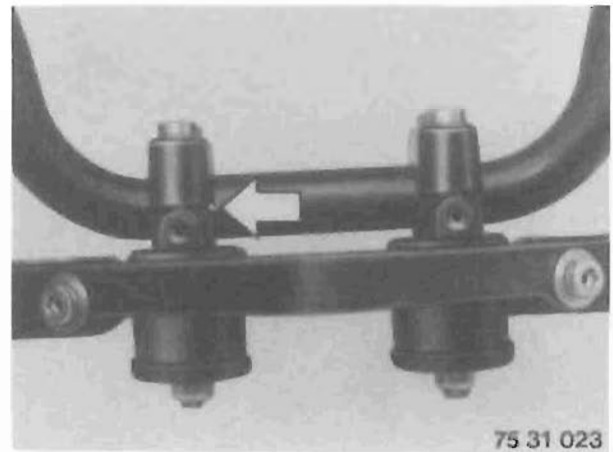

Steering head bearing – adjusting



Tighten stop screw (arrow).

Tighten the clamping screws first at the top, then at the base.

Tightening torques:

Stop screw 74 ± 5 Nm

Upper clamping screw 21 ± 2 Nm

Lower clamping screw 43 ± 3 Nm

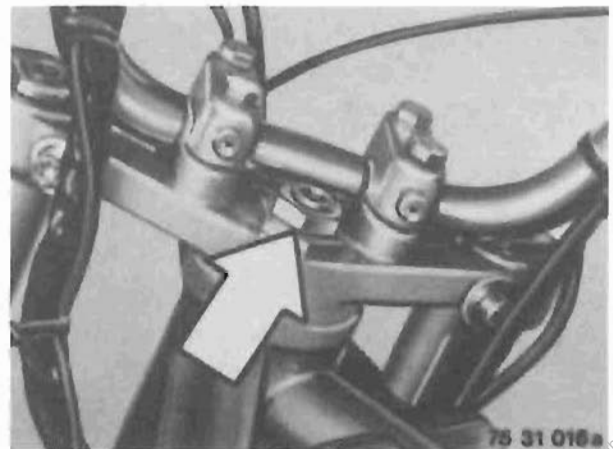

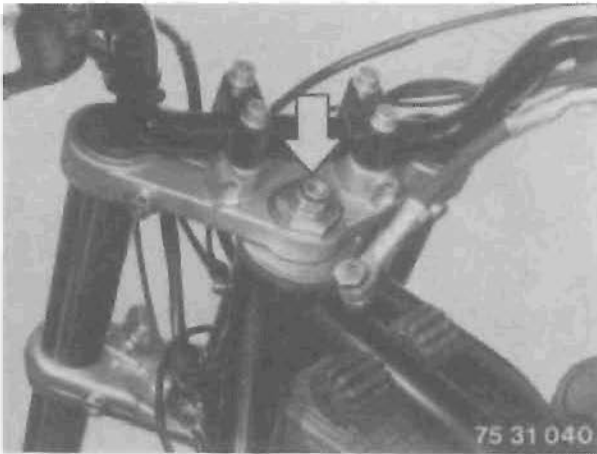

Remove the fluidbloc taper screws; tighten the locking tube (arrow).
Tighten the hex nut; tighten the clamping screws first at the top, then at the base.

Tightening torques:

Locking tube	$45 \pm 3 \text{ Nm}$
Hex nut, 5 mm deep	$45 \pm 3 \text{ Nm}$
Locking tube	$65 \pm 4 \text{ Nm}$
Hex nut, 7 mm deep	$65 \pm 4 \text{ Nm}$
Upper clamping screw	$21 \pm 2 \text{ Nm}$
Lower clamping screw	$43 \pm 3 \text{ Nm}$

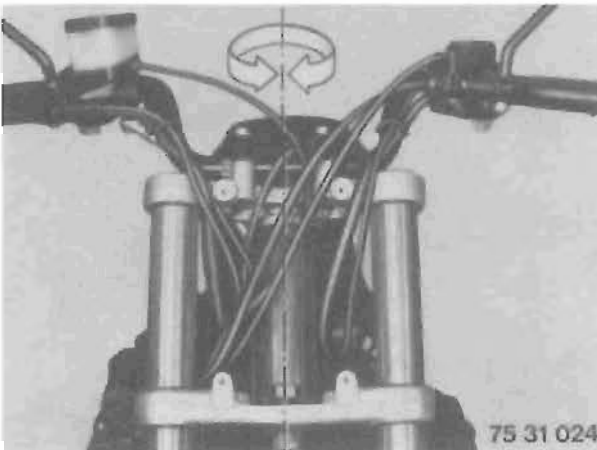

The telescopic fork must fall away randomly to either the left or right from its centre position when off-load.
Ensure that wire and electric cables are located properly: the electric cables should be located on the outside and the wire cables on the inside, above them.



Tighten fluidbloc taper screws.

Tighten torque:

Taper screws	$9 \pm 1 \text{ Nm}$
--------------	----------------------

Wire cables – adjusting

Connect up throttle cable to throttle butterfly system, connect up clutch cable and cable for increased starting speed.

Ensure that there are no kinks in the cables and that they are not subjected to tension when the handlebar is turned.

Note:

There should be 1 mm play at the handlebar fitting for the throttle cable.

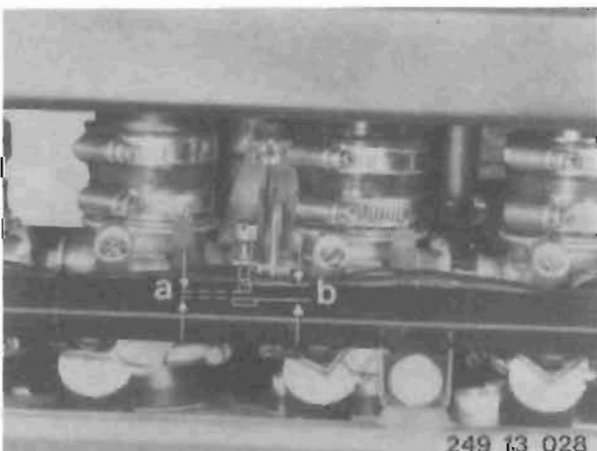

Push the cold-starting device on the handlebar to stage one and turn the adjusting screw until idle speed adjusting screw is raised through distance a. It must then move to distance b in stage two.



a = 1 mm
b = 2.5 mm



a = 1.5 mm
b = 3.0 mm

Distributor pipe – installing

Push distributor pipe up through steering head pipe.

When installing:

When installing, note lug at base of distributor pipe and on groove in the fork bridge.



Secure the distributor pipe with plastic nut (smooth side downwards).

Tightening torque:

Plastic nut

$10 \pm 1 \text{ Nm}$

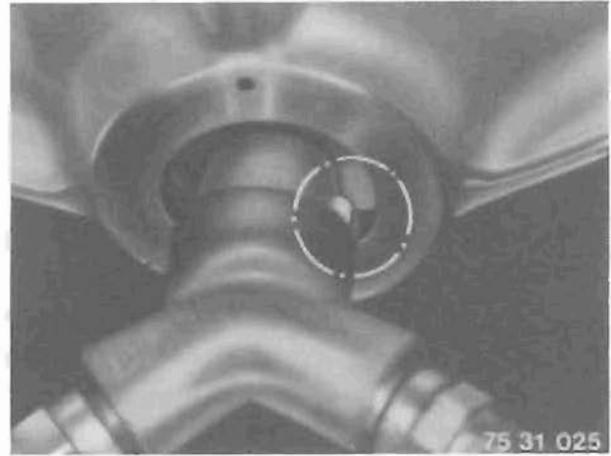

Fit clamp (arrow) on distributor pipe with a suitable tube (with spring lugs pointing upwards).

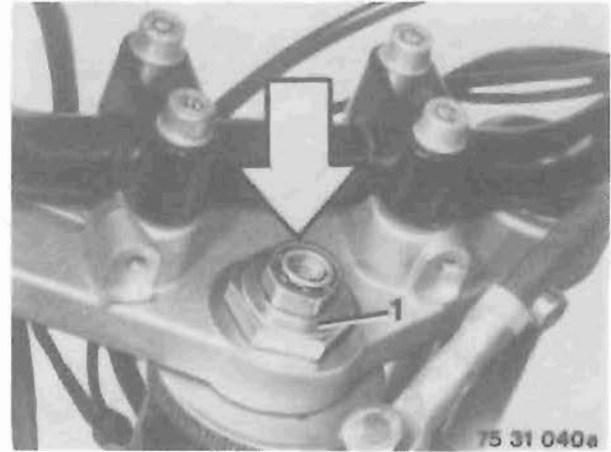

Secure brake hose to distributor pipe with hollow screw (arrow).

Renew sealing rings.

Tightening torque:

Hollow screw

$7 \pm 1 \text{ Nm}$

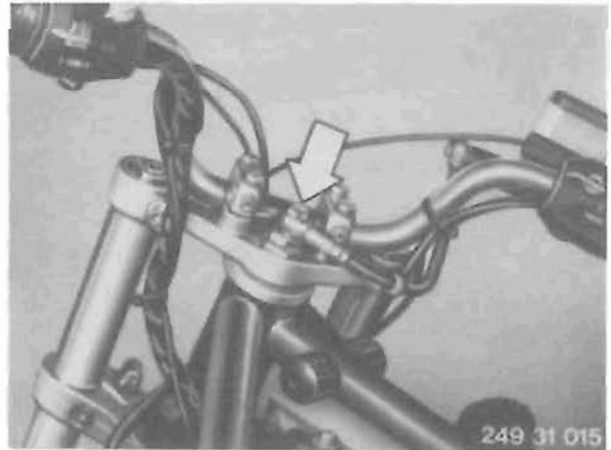

Turn handlebar to left-hand lock; pull handbrake lever several times and allow to detend back (bleed) until pressure builds up.

Press ignition lock into impact pad and secure impact pad.

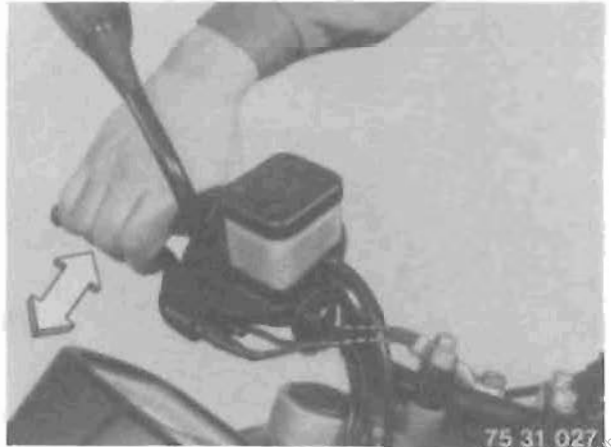

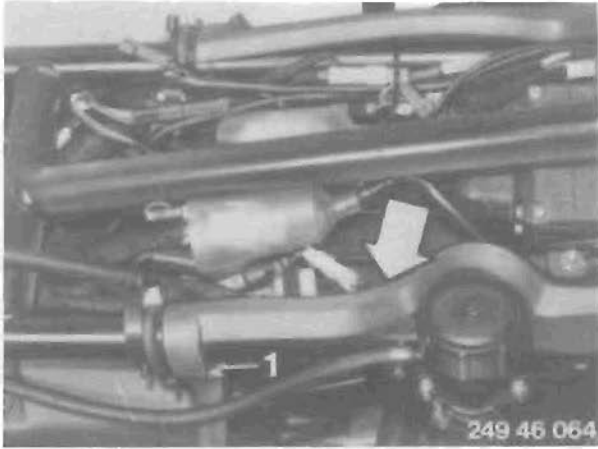

Divider – installing

K 100 RS, RT, LT

Place seal (arrow) on frame and secure with cable straps.
Insert the seal strip on the divider (1) between the upper section of the air cleaner housing and the collector, ensure it is properly located and secure together with the seal.



Install the coolant header tank next to the battery and secure with battery holder (arrow).

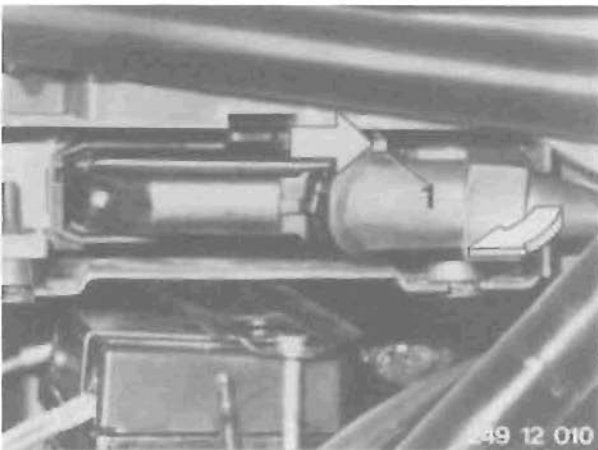

Engage the multi-pin plug first at the front and then press in at the rear until the securing loop (1) is heard to engage.
Insert the storage tray with fuel injection control unit.

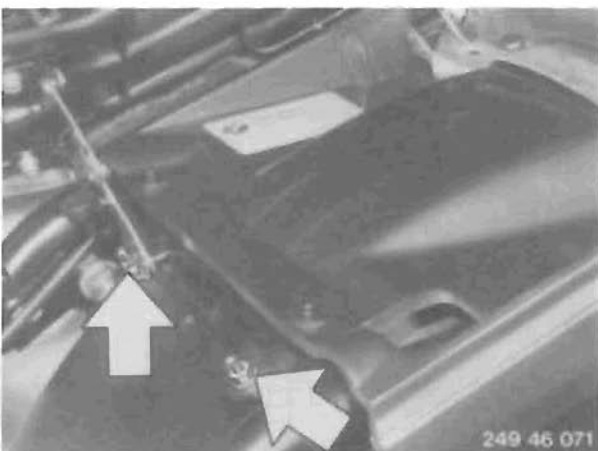

Rear mudguard – installing

Insert rear mudguard and lower section in lugs on gearbox. Insert loop with threaded pins through holes in mudguard and frame from the underside, screw on the nuts (arrows) and tighten.

Secure the spring strut to the frame

Tightening torque:

Spring strut to frame

$51 \pm 3 \text{ Nm}$



Rear section – installing

Fit large rubber discs and steel washers on the cage nuts on the rear frame section (arrows), and rubber discs with steel sleeve (1) on frame end welded-on lugs. Fit the rear section in such a way that the washers do not become displaced, and secure to the loop with recessed-head screws and Allen screws.

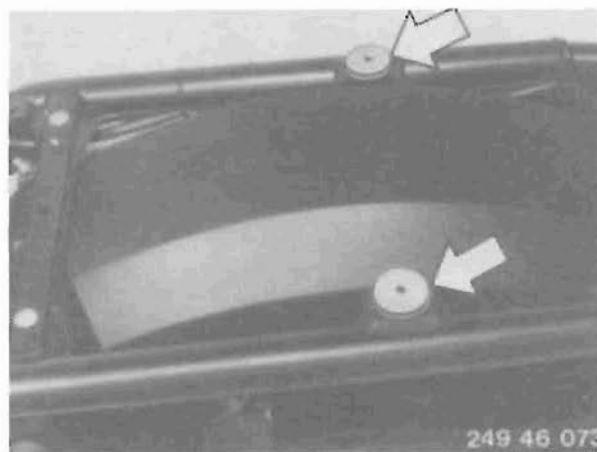

Push multi-pin plug into socket on rear section and secure rear light to rear section with knurled nuts (arrows).



Push loop with threaded pins through mudguard and storage compartment from beneath. Affix hex nuts and large washers loosely.

Push in licence plate holder, screw in recessed-head screws and tighten nuts in storage compartment.

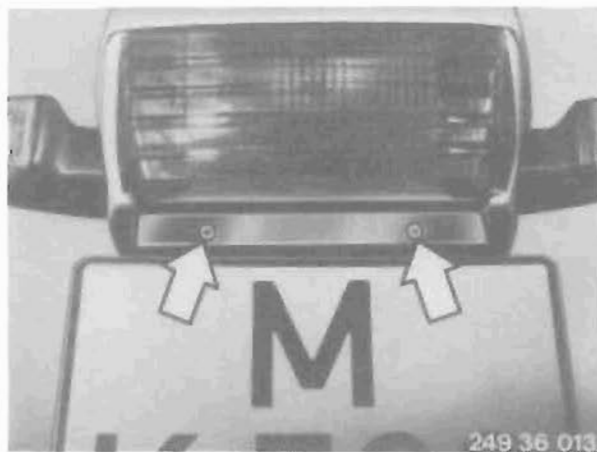

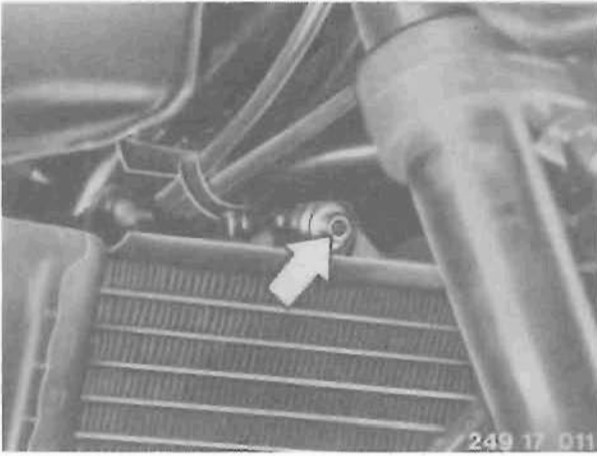

Radiator – installing

Insert radiator base in rubber bearing on frame, connect up fan motor and secure to frame with screw (arrow).

Secure coolant filler pipe, coolant hoses and overflow pipe to frame.

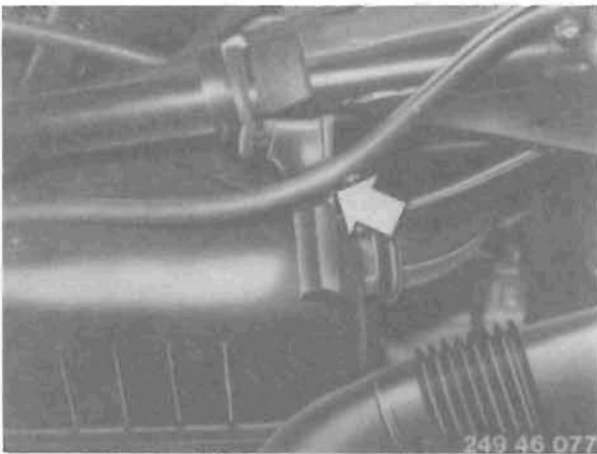

K 100 RS, RT, LT

Run overflow pipe (arrow) from filler pipe through passage in divider.

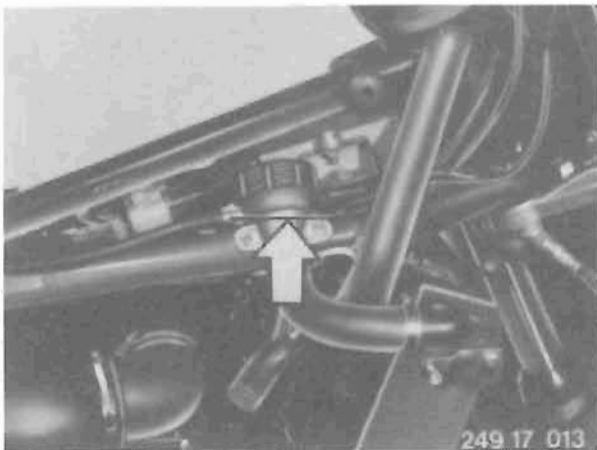

Coolant – topping up

Add coolant via filler pipe up to lower edge of overflow (arrow).

Note:

To bleed the radiator, turn over the engine with the starter motor and massage the coolant hose between the water pump and thermostat housing simultaneously. Add coolant if necessary.

Coolant mixture: 40 : 60

40% antifreeze to 60% water

for antifreeze protection down to -26°C

Coolant mixture: 50 : 50

for Scandinavian countries

for antifreeze protection down to -36°C

Screw the cap with seal on filler pipe.

Note:

Only use approved antifreeze grades.

See Technical Data, page 17–03.0.

Trim holder (only RS, RT): screw on to front frame struts at left and right.

Installing fuel tank: see page 16–01.0.

Dualseat – installing

Insert the hinged bolt and secure, locate the dualseat support in position and secure.

To set the dualseat lock, slacken off locking nut (arrow). Set the locking pin in such a way that the dualseat lies on the frame and the locking pin engages in the dualseat lock.

Tighten the locking nut again.

Installing fairing: see page 46–01.0.



Centre stand – removing and installing

Remove retaining screws (6) on either side. Disconnect the return springs (7).

Note:

The retaining screws are micro-encapsulated, and must not be re-used.

Models with rear disc brake:

Disconnect spring for main brake cylinder.

Bearing bushings for centre stand – removing and installing

Remove the Seeger ring (17) on the left-hand bushing. Lever out the bushing (5) at groove with screwdriver. Take off the centre stand (3).

Grease the pivot points and assemble the centre stand following the same procedure but in the reverse order.

When installing:

Clean thread passages of screws and holes with a thread cutter and apply Loctite 242.

Tightening torque:

Retaining screw for centre stand to pivot block 41 ± 5 Nm

Pivot block – removing and installing

Remove centre stand and bearing bushings as described above. Remove retaining screw (11) for side stand (9).

Remove retaining screws (2) for pivot block (2) on gearbox.

Note:

The side stand and pivot block retaining screws are micro-encapsulated, and must not be re-used.

Install following the same procedure but in the reverse order.

When installing:

Clean thread passages of screws and holes with a thread cutter and apply Loctite 242.

Tightening torques:

Retaining screws for pivot block to gearbox 41 ± 5 Nm

Retaining screw for side stand to pivot block 41 ± 5 Nm

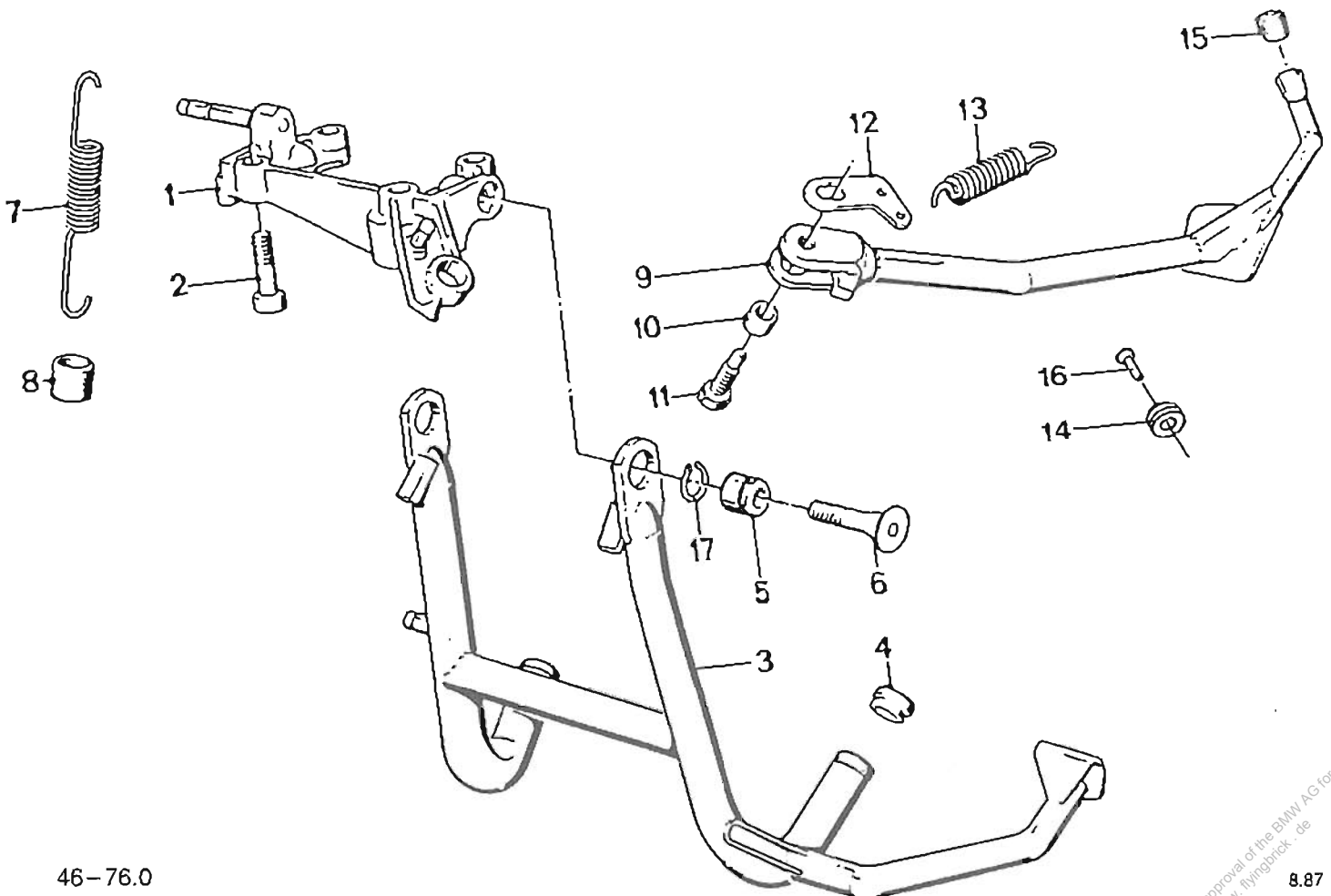

Lift handle – removing

Lever off spring bearing (arrow) on handle with a screwdriver.
Pull the spring bearing off the spring.

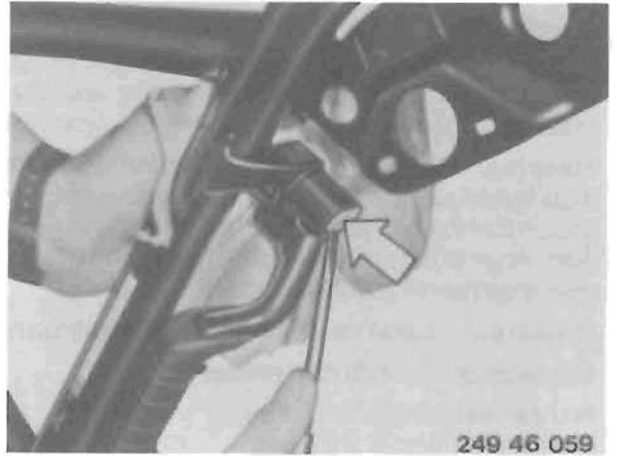

Lift handle – installing

Fit lift handle on the greased tube on frame.
Grease the spring and push into upper spring bearing in tube.
Push out spring with a screwdriver far enough to engage the lower spring bearing.

Note:
Spring bearings must engage in grooves.

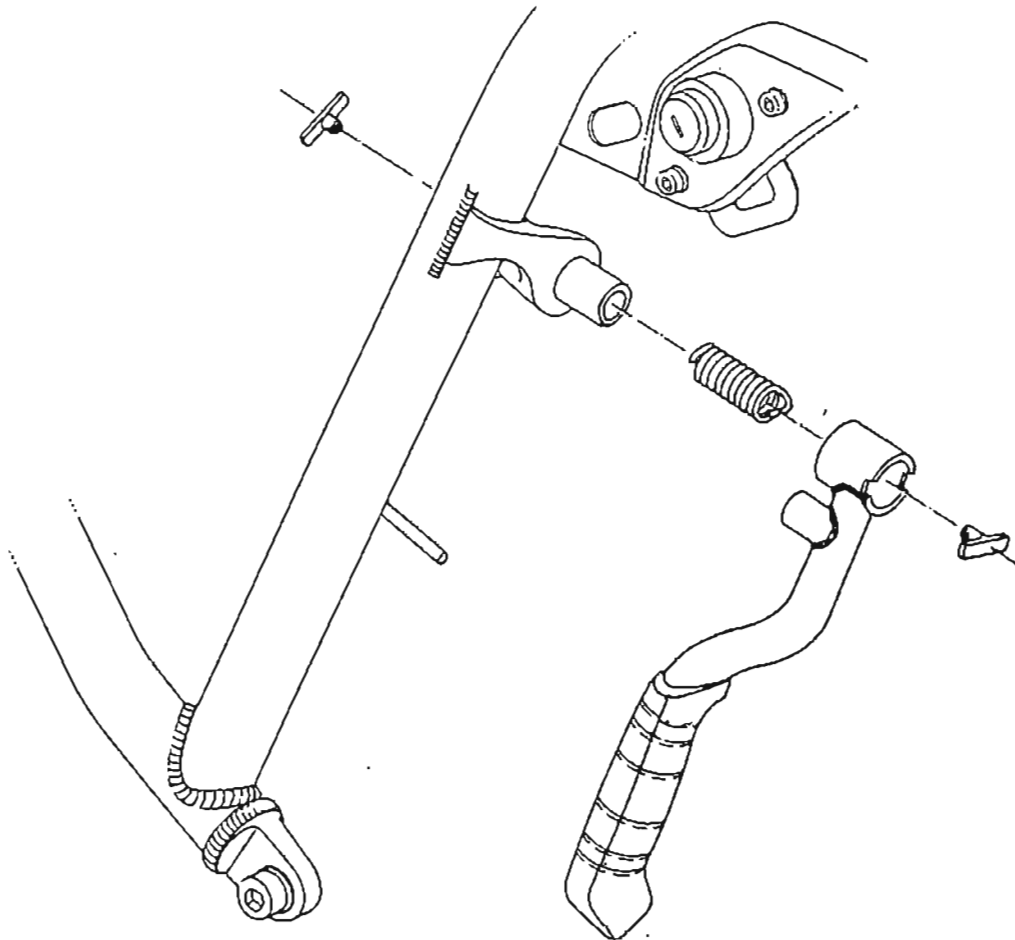
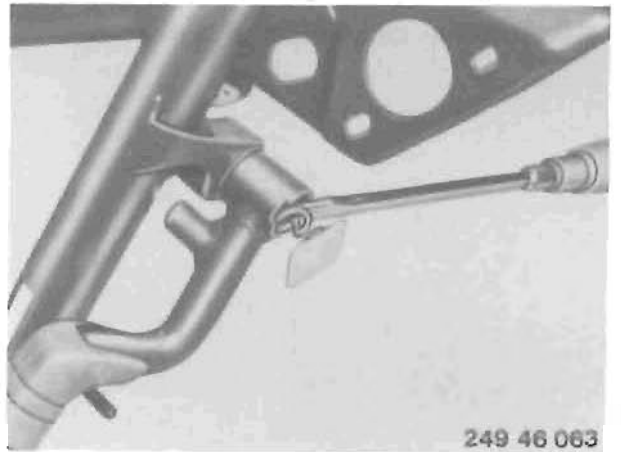

Wheel offset – measuring

Motorcycle geometry can be measured very simply with BMW wheel offset gauge 36 3 920.

Deviations and changes resulting from an accident which affect the frame or telescopic forks usually have a highly marked effect on road behaviour. Measuring wheel offset will reveal whether the motorcycle's geometry has altered.

Place the motorcycle on a level floor or lifting platform. Apply the wheel offset gauge to the right-hand side of the motorcycle. Set the adjustable supports so as to locate the measuring plane as close to the wheel centre as possible and so that the gauge can slide freely along the motorcycle. – The measuring stops must only make contact with the outer edge of the rim and **not** the tyre. Insert the pull hook in the cast or wire spoke and carefully pull the gauge to the rear wheel until it is firmly attached.

Measure and calculate wheel offset "S" as shown on page 46–79.0.

The exterior rim width for K models is:

Front wheel: 82 mm ± 0.5 mm

Rear wheel: 89 mm ± 0.5 mm

These figures are only outline values, and are not intended as a substitute for actual measurements.

Maximum permitted wheel offset: 5 mm.

Calculation of wheel offset "S"

EXAMPLE 1 –

Front and rear wheels of identical rim width

Formula: $A - B = S$

E.g.:

Reference value: $A \hat{=} 50 \text{ mm}$

Measured value: $B \hat{=} 46 \text{ mm}$

Calculation: $50 - 46 = 4 \text{ mm wheel offset "S"}$

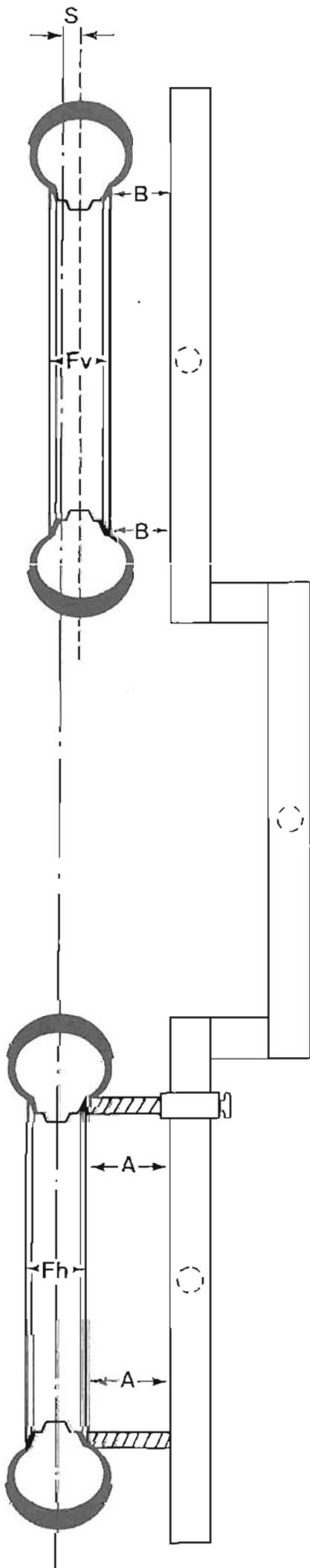

EXAMPLE 2 –

Front and rear wheels of differing rim widths

Formula: $A + \frac{Fh}{2} - \left(B + \frac{Fv}{2} \right) = S$

E.g.:

Reference value: $A \hat{=} 50 \text{ mm}$
 + half wheel rim: $\frac{Fh}{2} \hat{=} 44.5 \text{ mm}$ } = 94.5 mm

Measured value: $B \hat{=} 52 \text{ mm}$
 + half wheel rim: $\frac{Fv}{2} \hat{=} 41 \text{ mm}$ } = 93 mm

Calculation: $94.5 - 93 = 1.5 \text{ mm wheel offset "S"}$

Frame – checking

In the event of an accident, the forces affecting the motorcycle frame are not comparable with those arising during normal operation. If the frame has not been visibly affected by an accident, it can be checked with BMW frame checking gauge 46 5 600.

K 100 RS: removing fairing – see page 46–28.0.

K 100 RT, RL: removing fairing – see page 46–39.0.

K 75 c: removing cockpit – see page 46–15.0.

K 75 s: removing fairing – see page 46–21.0.

Telescopic fork – removing: see page 31–11.0.

The taper roller bearing outer races remain in the steering head.

Screw on BMW adapter 46 5 606 (arrow) instead of the rear engine retaining screws.

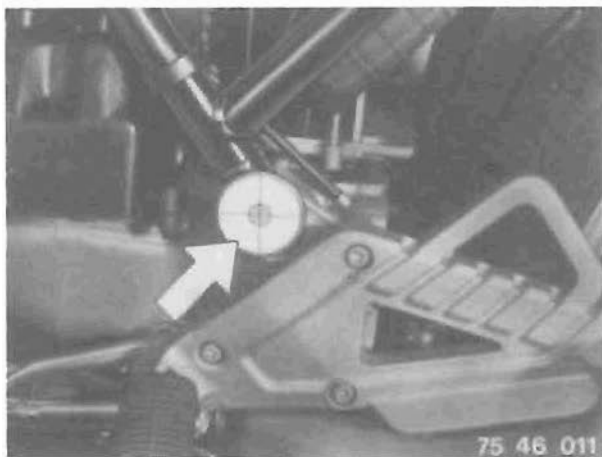

Screw measuring discs (arrow) on the adapter at either side at the same level.

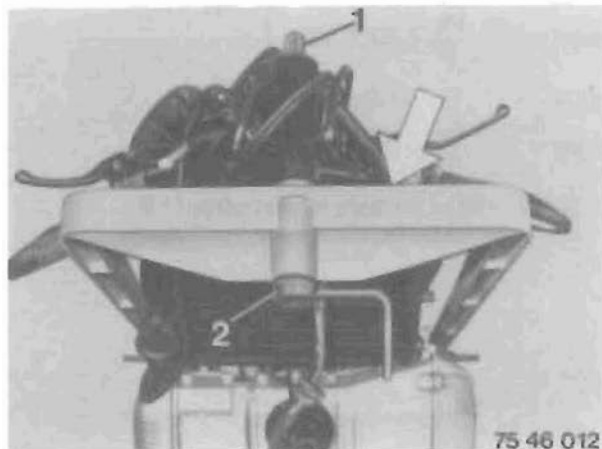

Apply the frame gauge (arrow) to the steering head from below and clamp together frame and gauge with spindle (1), washer and nut (2).

Insert the lightly greased measuring arbors in the rear holes (b) on the frame checking gauge.
Align the gauge in such a way that the same value is shown on the measuring scale on either side when the measuring points are gently touching the measuring discs.

The frame is in good order if the measuring points are at approximately the same position on either side within the tolerance circle (maximum deviation between left and right: 2 mm = 2 squares).

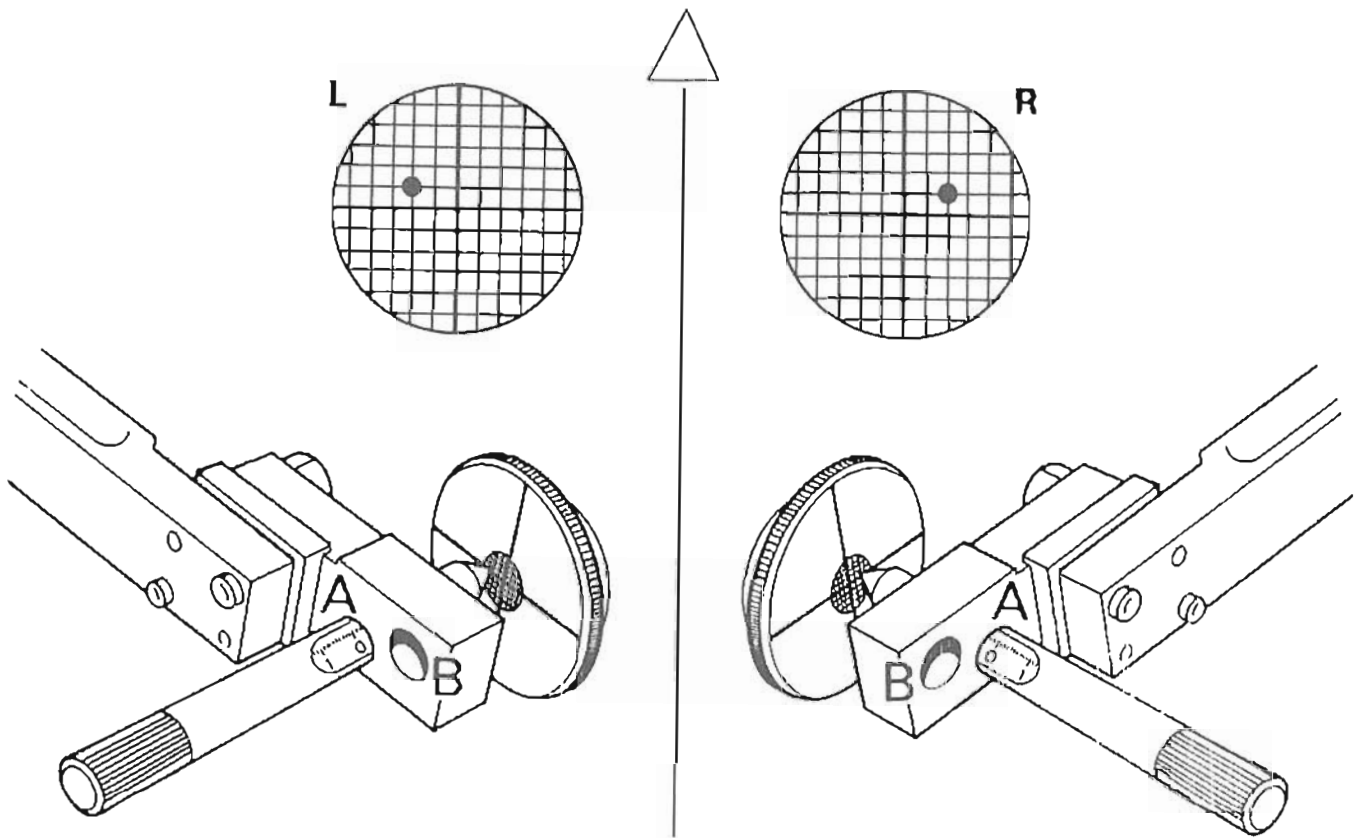
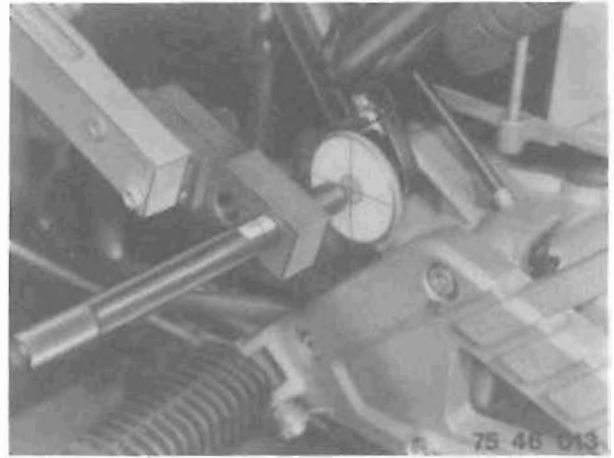

51

Equipment

51 Equipment

Steering lock – removing	Page 51–03.0
Dualseat lock – removing and installing	51–03.0

Steering lock – removing

Destroy plastic cover on steering lock and remove.
Lever grooved pin out of frame with side cutters.
Steering lock version with cover:
Lever off cover with screwdriver.
Release steering lock with key and pull out.



Install the lock in the reverse order.
Always replace the grooved pin.

- 1 Spring washer
- 2 Cover
- 3 Steering lock
- 4 Coil spring
- 5 Semi-circular grooved pin, 3 × 9

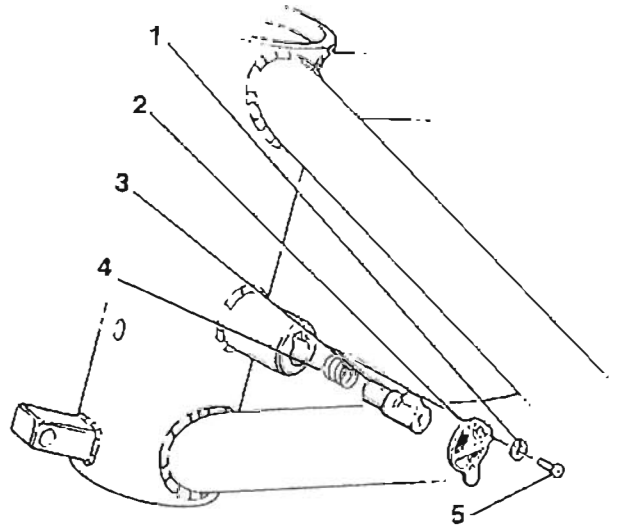

Dualseat lock – removing and installing

Remove retaining screws (1, 2) and take off lock.
If the lock is changed, it may be necessary to readjust the catch on the dualseat.



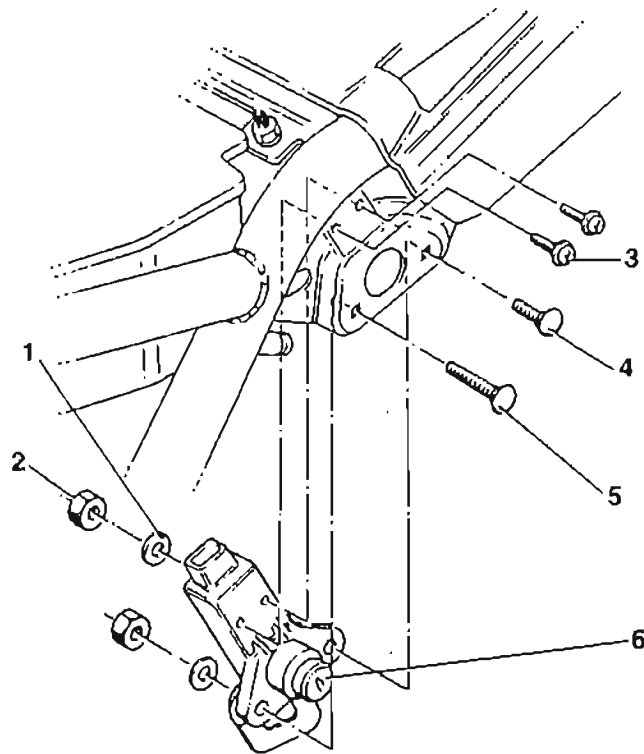

- 1 2 washers
- 2 2 hex nuts
- 3 Sheet metal nut, DIN 7981
- 4 Round-head bolt
- 5 Round-head bolt
- 6 Dualseat lock

52

Dualseat

52 Dualseat

Diagrams	Page 52-03.0
Dualseat – removing and installing	52-04.0

Dualseat on frame

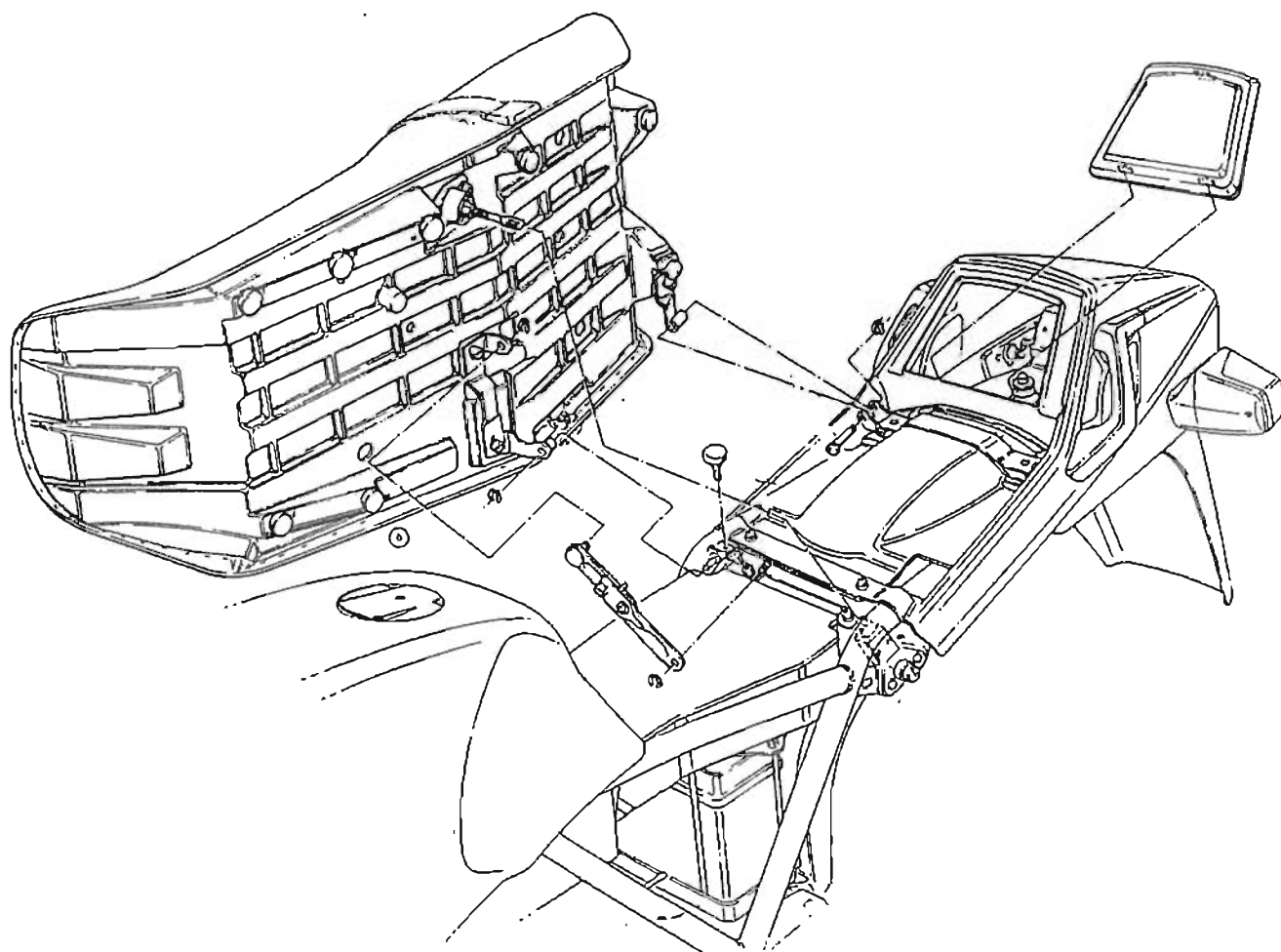

Dualseat – removing

Remove battery cover on right.
Pull circlip off pin on frame.

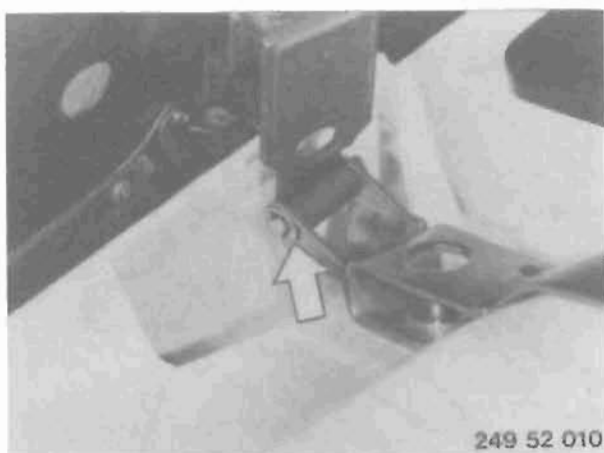

Fold up the dualseat.
Pull circlip off rear dualseat hinge and take out pin.

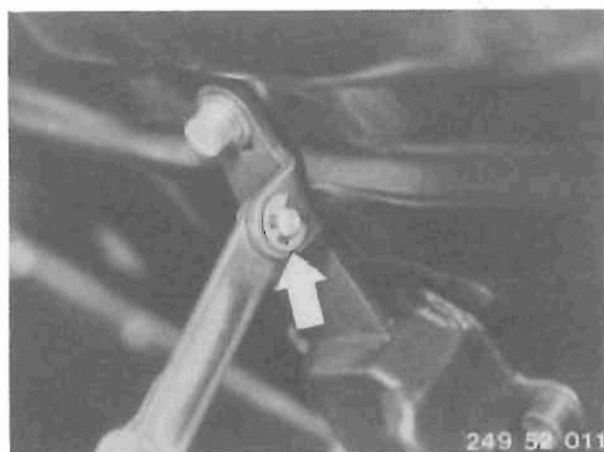

Pull circlip (arrow) off dualseat support and pull dualseat support out of front hinge.
Raise the dualseat at the rear and pull forward to remove from pin on frame.



Dualseat – installing

Assemble following the same procedure but in the reverse order.

To adjust the dualseat lock, slacken off the locking nut (arrow). Adjust the locking pin so that the dualseat makes contact with the frame and the locking pin engages in the dualseat lock.

Tighten locking nut again.

61

General electrical system

61 General electrical system

Specifications	Page	61-03.0
Diagrams		61-05.0
Battery – removing and installing		61-07.0
Left or right horn, K 75 c, K 100 – removing and installing		61-09.0
Headlight fairing – removing		61-09.0
Cockpit fairing – removing		61-09.0
Headlight – removing		61-09.0
K 75 horn – removing and installing		61-10.0
K 75 s horn – removing and installing		61-10.0
Left or right horn, K 100 RT, LT – removing and installing		61-10.0
Left or right horn, K 100 RS – removing and installing		61-11.0

General electrical system

Specifications

Model		K 75	K 75 c	K 75 s	K 100	K 100 RS	K 100 RT	K 100 LT
Battery		BMW Mareg with transparent polypropylene housing						
Standard version	V/Amp/h	12/20						12/30
Special version	V/Amp/h	12/30						
Alternator		Three-phase, with fully electronic regulator, direct drive (ratio 1 : 1.5)						
Output	W	460						
Starter		Permanent-magnet version with four stage reduction gears (27 : 1) and freewheel						
Output	kW	0.7						
Power circuit fuses		"Minifuse" (flat-type) fuses, 7 circuits						
Maximum load	A	7.5 (3 circuits)						
	A	15 (4 circuits)						

Cable connector arrangement on frame

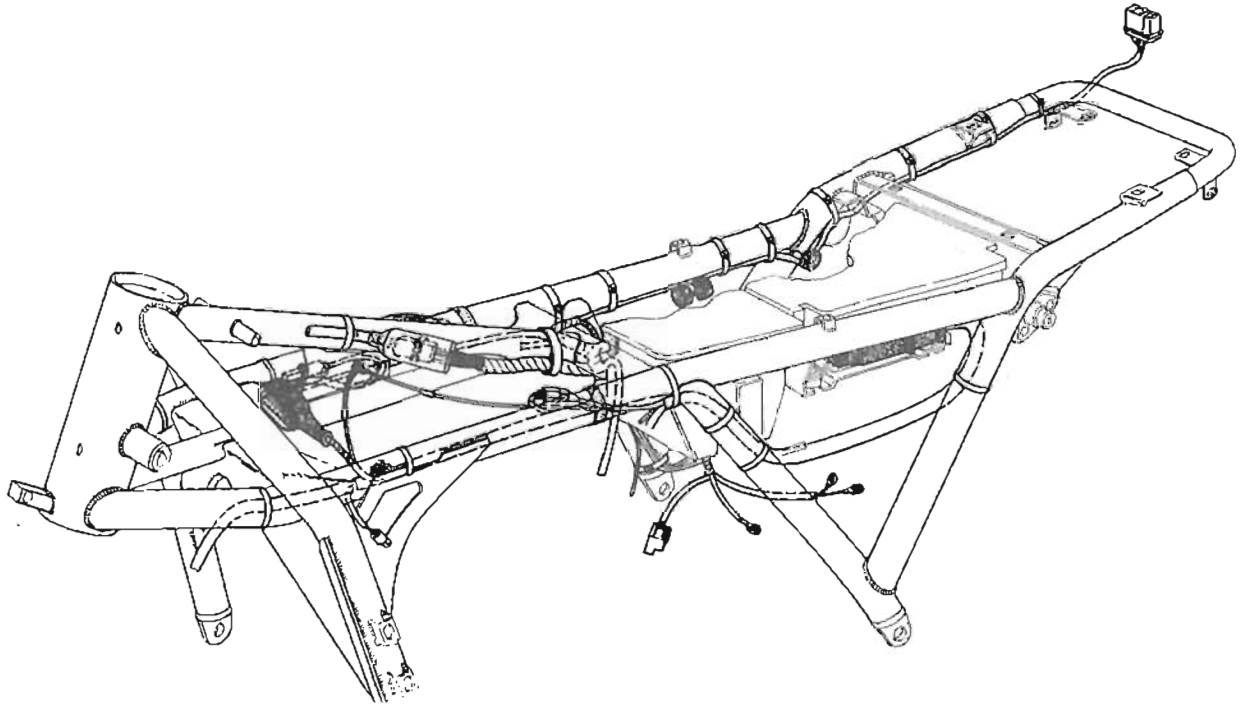

View from right

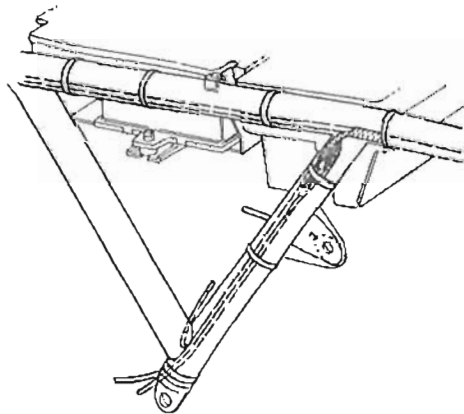

Electrical equipment box

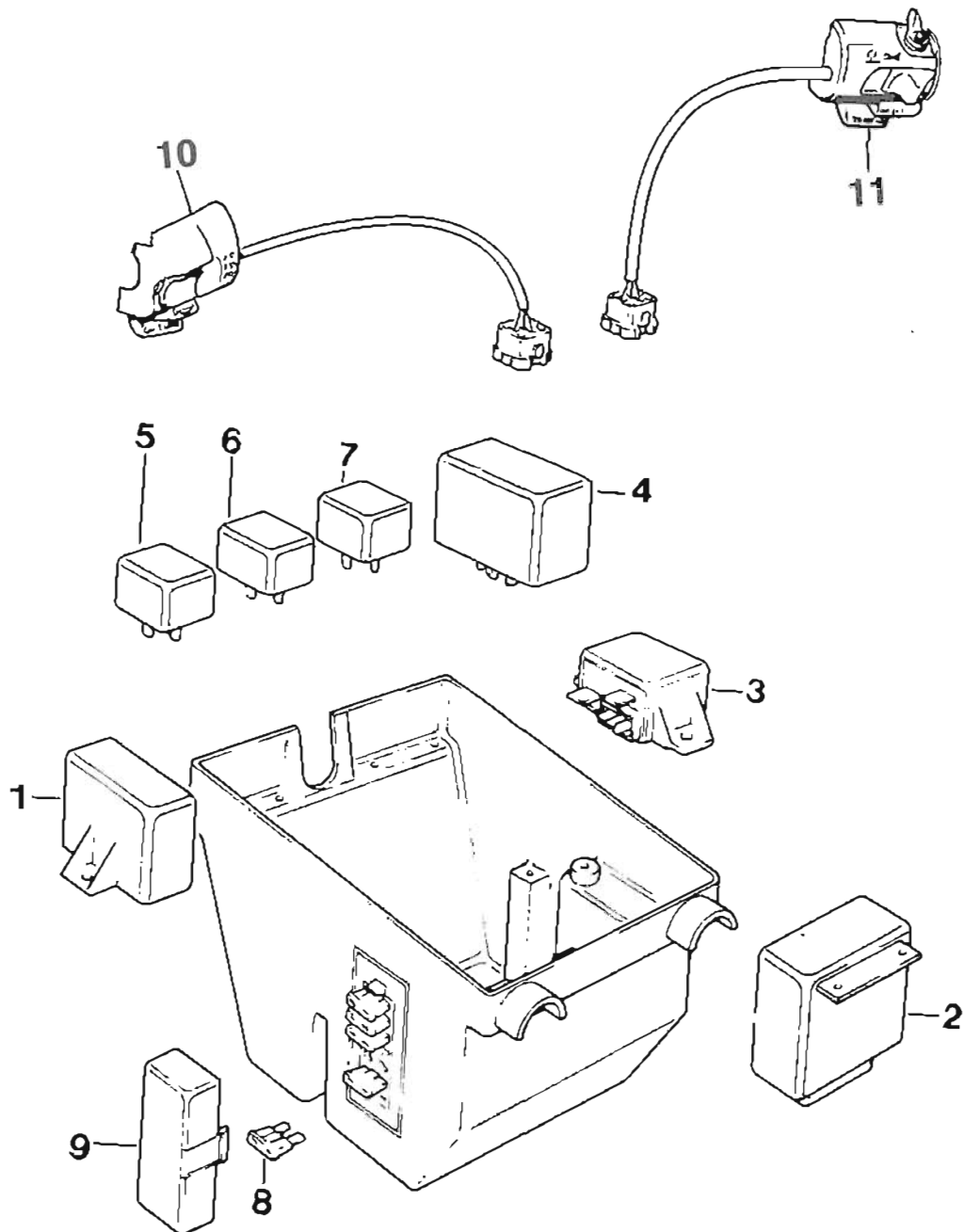

- 1 Bulb monitor
- 2 Turn indicator and hazard warning flasher relay
- 3 Starter relay
- 4 Temperature switch
- 5 Load-shedding relay
- 6 Horn relay
- 7 Electric fuel pump relay
- 8 "Minifuse" fuses
- 9 Fuse cover
- 10 Left-hand fitting
- 11 Right-hand fitting

Battery – removing and installing

Remove the battery cover on left and right (see illustrations).



- 1 = Carefully pull off frame at base.
- 2 = Push down to remove from fixture (at fuel tank).
- 3 = Pull forward and take off.

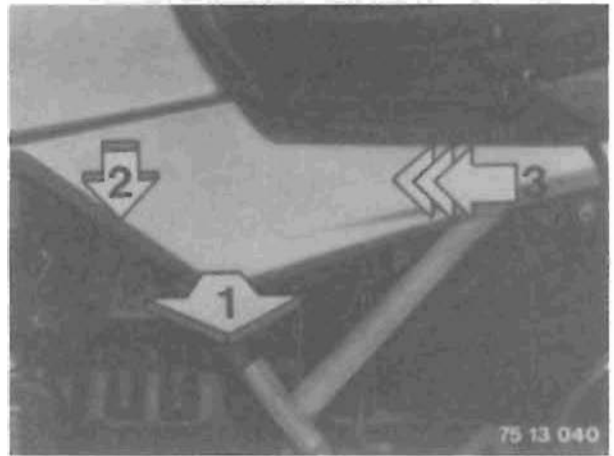

Fuel tank with bridge mounting

- 1 = Carefully pull off frame.
- 2 = Carefully pull off frame.
- 3 = Carefully pull back from arbor on frame to remove.

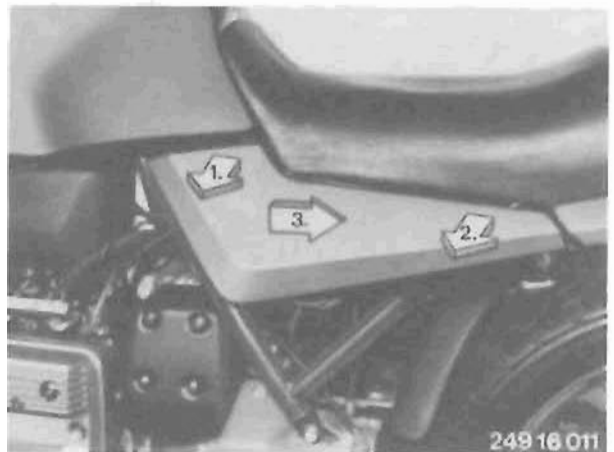

Fuel tank without bridge mounting

- 1 = Carefully pull off frame.
- 2 = Carefully pull off frame.
- 3 = Carefully pull forward out of dualseat frame to remove.

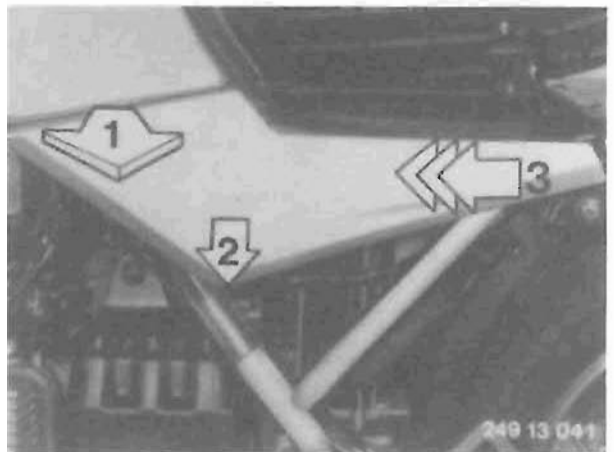

Pull off cover for fuel injection control unit in the direction of arrow.



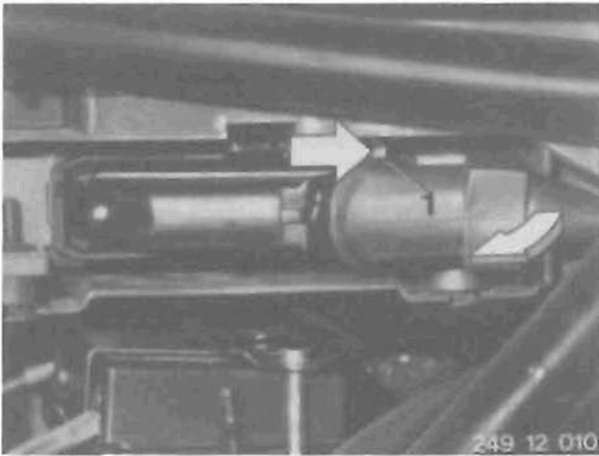

Push retaining bracket (1) on multiple plug back in the direction of the arrow with a screwdriver. Pull out multiple plug to rear and take out of the front guide.

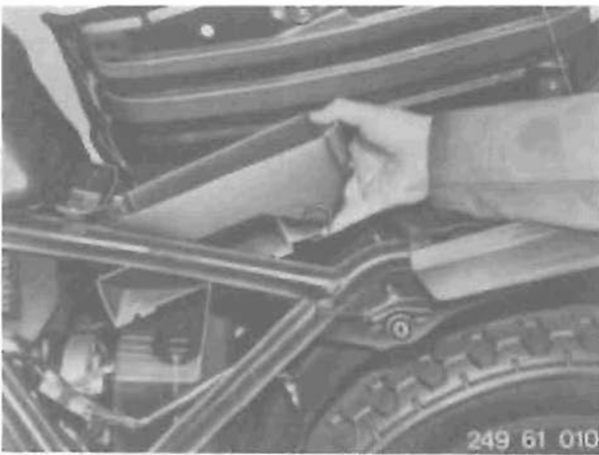

Lift up storage tray with control unit to remove.



Take out the screws for the battery carrier (arrows), take off the battery cover and detach the leads from the positive and negative posts.

Lift out the battery, noting the battery vent hose.

Assemble following the same procedure but in the reverse order.

Left or right horn, K 75 c, K 100 – removing and installing

Headlight fairing – removing

Remove retaining screws on left (arrows) and right, pull the fairing forward to remove and allow to hang down freely.

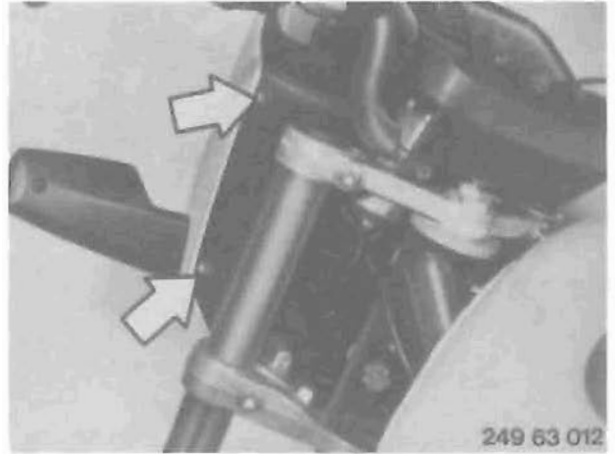

Cockpit fairing – removing

Remove retaining screws (arrows) for cockpit holder on left and right. Tilt forward cockpit fairing together with turn indicator housing. Disconnect turn indicator lead plug and take off the cockpit fairing.

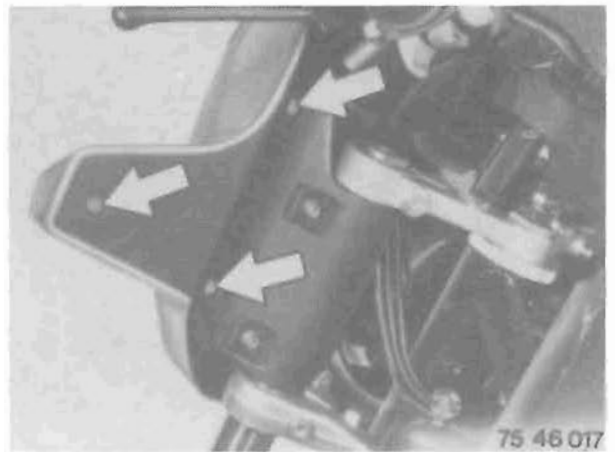

Headlight – removing

Disconnect headlight plug. Slacken off headlight retaining screw and take off headlight.

When installing:

The marks (arrow) on holder must be aligned when assembling.



Pull off the cable shoes at the horn on the left or right and unscrew the retaining nut (arrow). Assemble following the same procedure but in the reverse order.

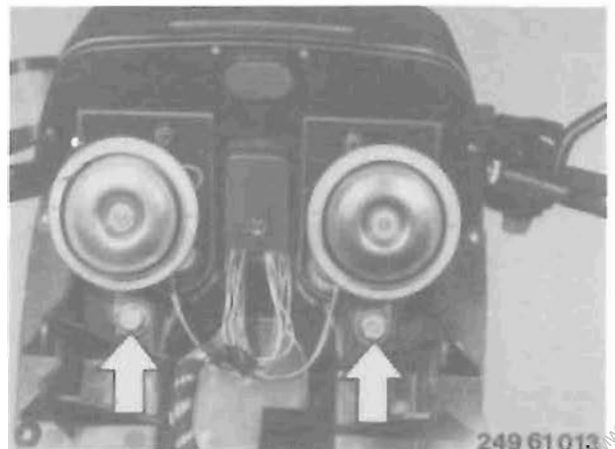

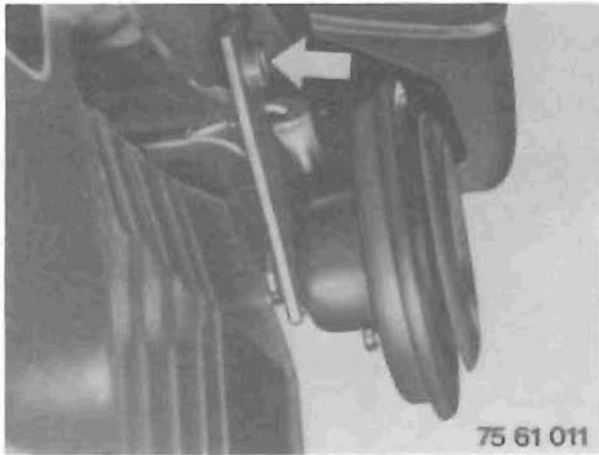

K 75 horn – removing and installing

Remove retaining screw (arrow) at base on radiator. Pull cable shoe off horn.

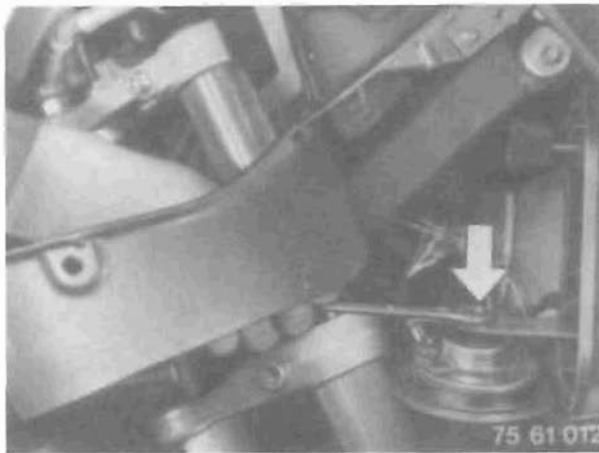

K 75 s horn – removing and installing

Slacken off retaining nut (arrow) from rear, as illustrated. Pull the horn down to remove and pull off cable shoes.

Note:

To provide a better picture, the side fairing has been removed here.

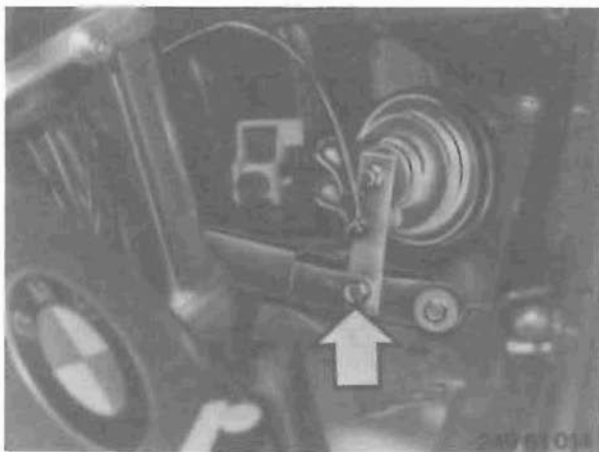

K 100 RT, LT right or left horn – removing and installing

Remove knee pad and storage compartment on left or right (see Group 46).

Pull off cable shoes for horn.

Remove retaining screw (arrow).

Assemble following the same procedure but in the reverse order.

K 100 RS right or left horn – removing and installing

Remove knee pads (see Group 46).

Press out interior cover (arrow) for strut at lower edge.

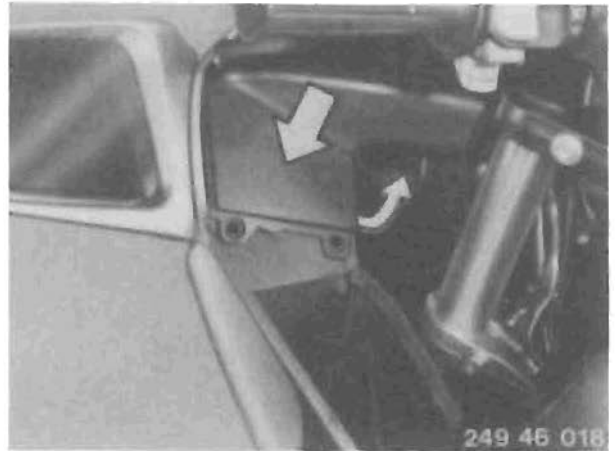

Remove retaining screws (arrows) for interior cover holder.

Lift up interior cover slightly and slacken off retaining screw behind fairing holder (do not remove nut).

Take out holder.

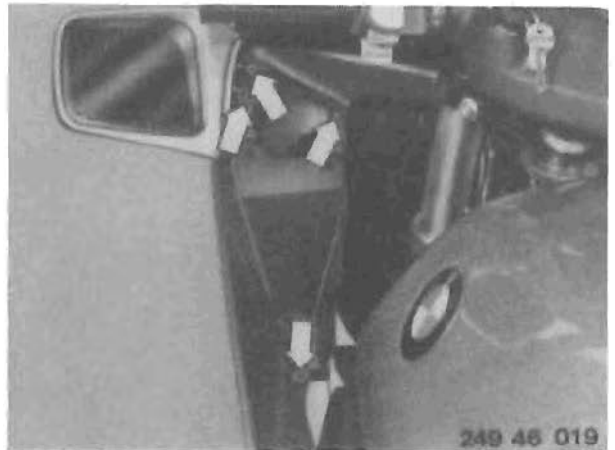

Pull cable shoes for horn and remove retaining nut (arrow).

Assemble following the same procedure but in the reverse order.



62

Instruments

62 Instruments

Diagrams	Page 62-03.0
K 75 c, K 100 instrument cluster – removing and installing	62-05.0
Headlight fairing – removing	62-05.0
Cockpit fairing – removing	62-05.0
Headlight – removing	62-05.0
K 75 Instrument cluster – removing and installing	62-06.0
K 75 s instrument cluster – removing and installing	62-07.0
K 100 RT, LT instrument cluster – removing and installing	62-07.0
K 100 RS instrument cluster – removing and installing	62-08.0
Instrument cluster – stripping down and assembling	62-09.0
Printed circuit board – removing and installing	62-09.0
Quartz clock – removing and installing	62-10.0
Telltale light frame – removing and installing	62-10.0
Fuel gauge board – removing and installing	62-11.0
Revolution counter – removing and installing	62-11.0
Revolution counter dial – removing and installing	62-11.0
Gear indicator board – removing and installing	62-11.0
Speedometer board – removing and installing	62-12.0
Speedometer – removing and installing	62-12.0
Telltale light – renewing	62-12.0

Instrument cluster

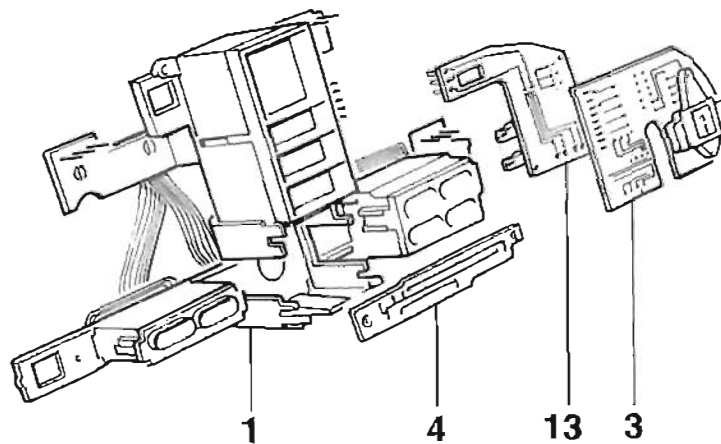
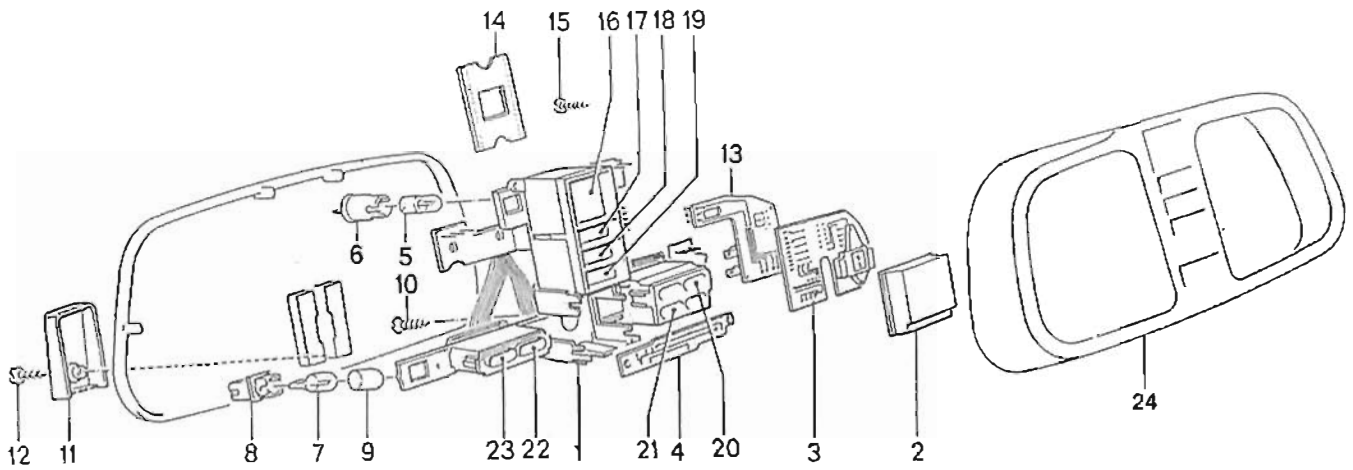

- | | |
|-------------------------|-----------------------|
| 1 Printed circuit board | 13 Fuel gauge board |
| 2 Cover | 14 Gasket |
| 3 Gear display board | 15 Retaining screw |
| 4 Speedometer board | 16 Green glass, large |
| 5 Telltale | 17 Blue glass |
| 6 Lamp holder | 18 Red glass |
| 7 Telltale | 19 Green glass |
| 8 Lamp socket | 20 Red glass |
| 9 Cap | 21 Yellow glass |
| 10 Retaining screw | 22 Red glass |
| 11 Cover cap | 23 Red glass |
| 12 Retaining screw | 24 Housing |

Instrument cluster

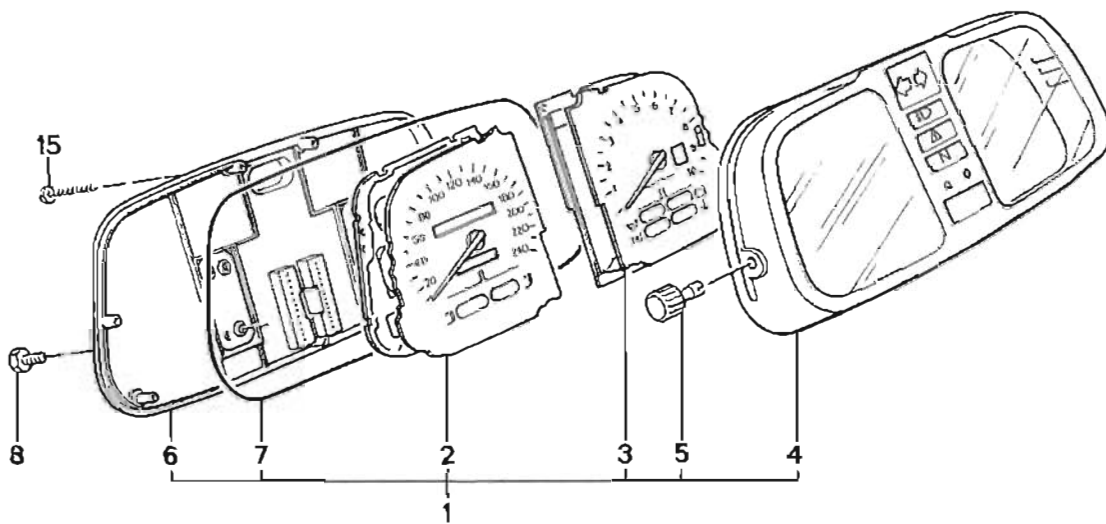

- 1 Instrument cluster
- 2 Speedometer
- 3 Revolution counter
- 4 Housing
- 5 Reset button

- 6 Rear panel
- 7 Gasket
- 8 Retaining screw
- 15 Retaining screw

K 75 c, K 100 instrument cluster – removing and installing

Headlight fairing – removing

Remove retaining screws on left (arrows) and right, pull the fairing forward to remove and allow to hang down freely.

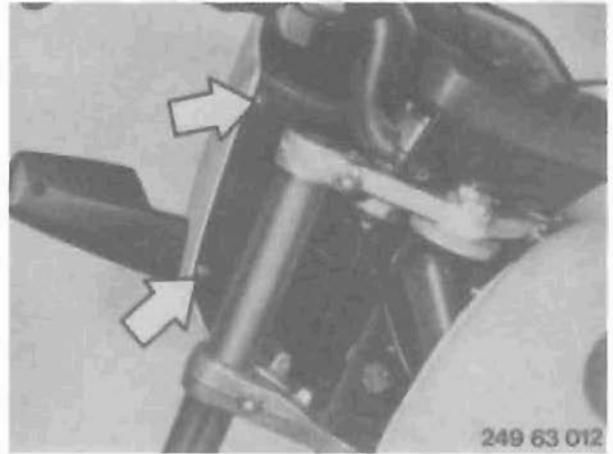

Cockpit fairing – removing

Remove retaining screws (arrows) for cockpit holder on left and right. Tilt forward cockpit fairing together with turn indicator housing. Disconnect turn indicator lead plug and take off the cockpit fairing.

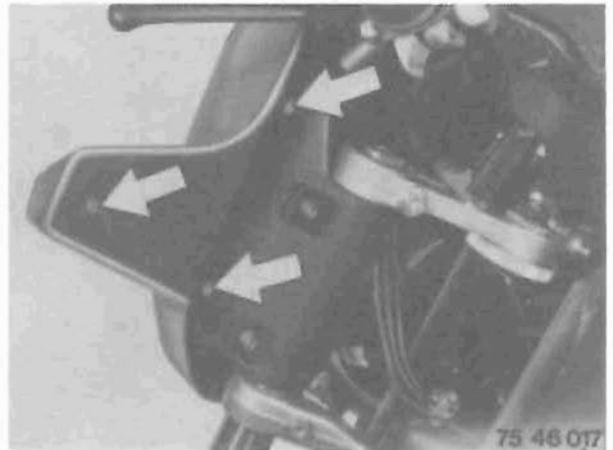

Headlight – removing

Disconnect headlight plug. Slacken off headlight retaining screw and take off headlight.

When installing:

The marks (arrow) on holder must be aligned when assembling.

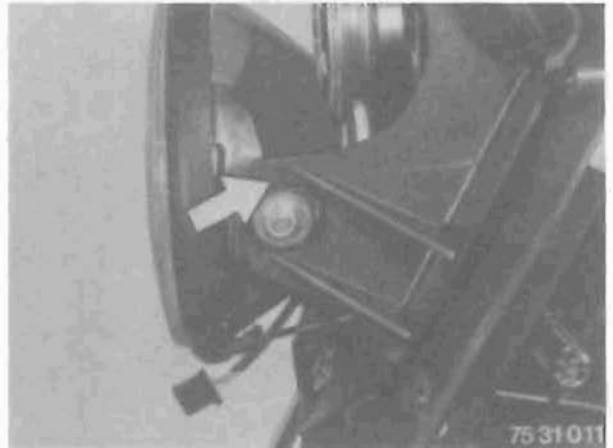

Disconnect electric plugs (arrow) on horn. Remove retaining screws for cap (1) and take off cap. Pull out multi-pin plug.

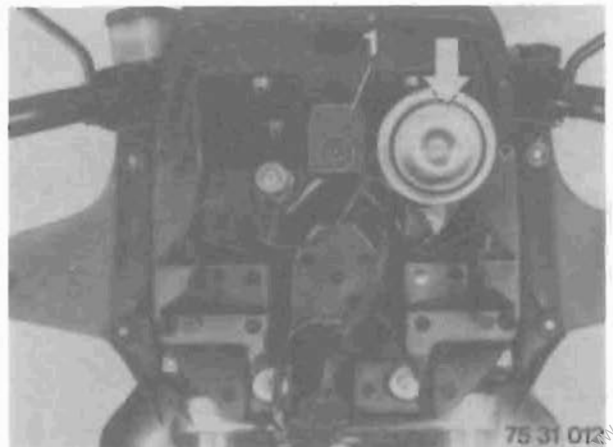

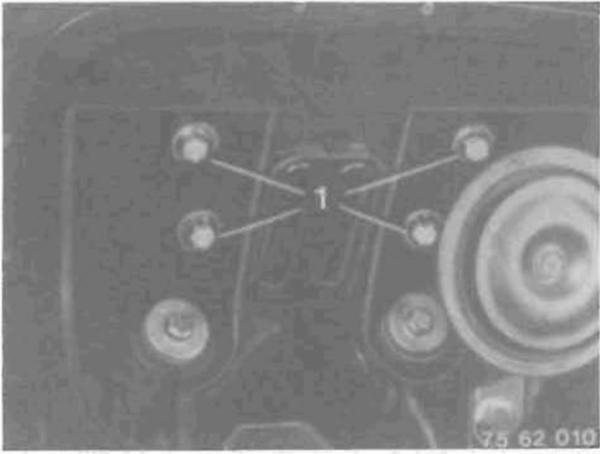

Remove four retaining screws (1) for instrument cluster and take out instrument cluster.
Assemble following the same procedure but in the reverse order.

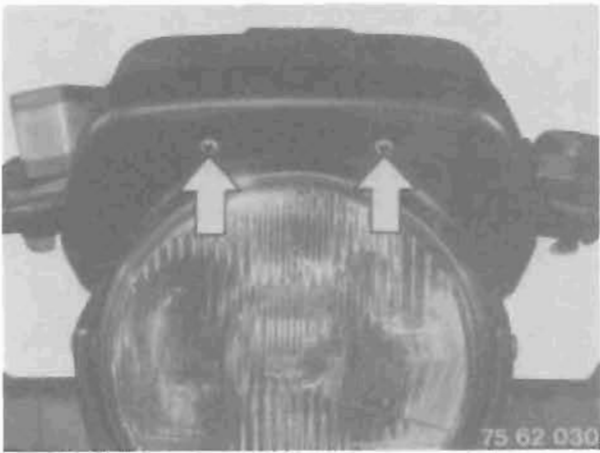

K 75 instrument cluster – removing and installing
Remove retaining screws (arrows) with angled Phillips-head screwdriver.

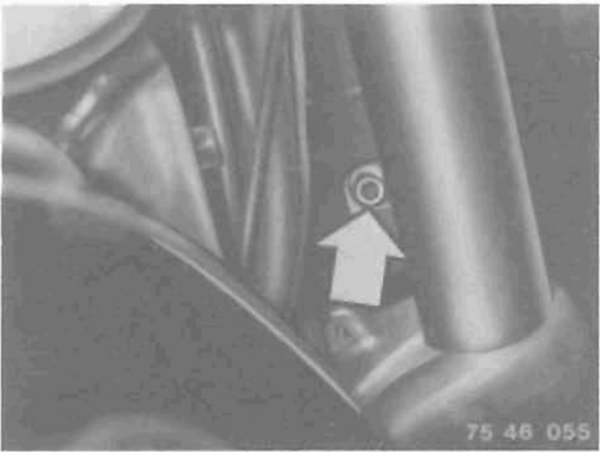

Remove retaining screws on right (arrow) and left of rear panel.



Take off cap (1) for instrument combination plug.
Pull off plug.
Remove four retaining screws (arrows) and take off instrument cluster.
Assemble following the same procedure but in the reverse order.

K 75 s instrument cluster – removing and installing

Remove fairings (see Group 46).
Take off cap (1) for instrument cluster plugs.
Pull out plugs (2 and 3).



Remove four retaining screws (arrows) for instrument cluster and take off instrument cluster.
Assemble following the same procedure but in the reverse order.

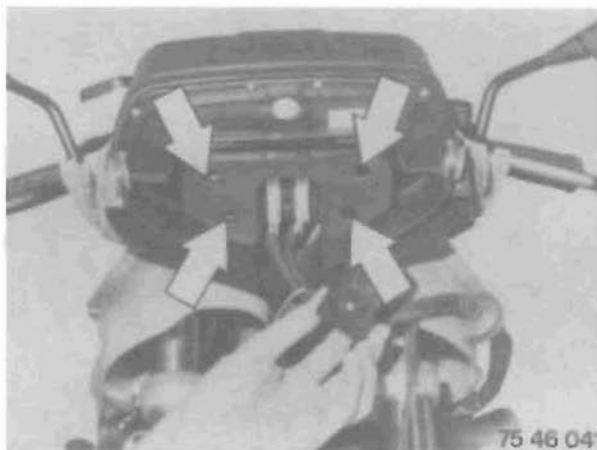

K 100 RT and LT instrument cluster – removing and installing

Remove knee pads and storage compartment (see Group 46)
Remove retaining screws on left and right (arrows).

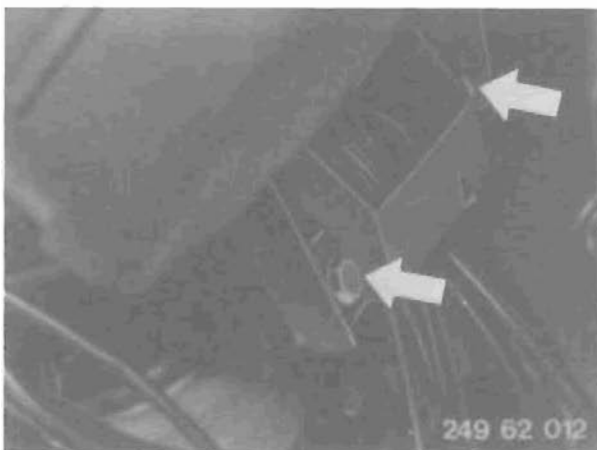

Lift up instrument cluster slightly, remove cap (1) and disconnect plug. Take out the instrument cluster.



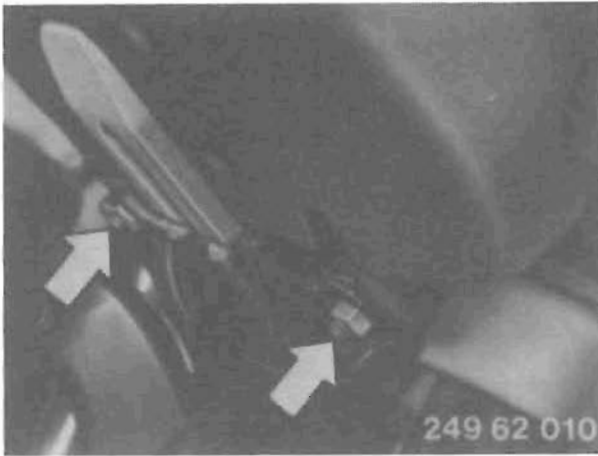

K 100 RS instrument cluster – removing and installing

Remove impact pad and set down on fuel tank. Remove retaining nuts on left and right (arrows).

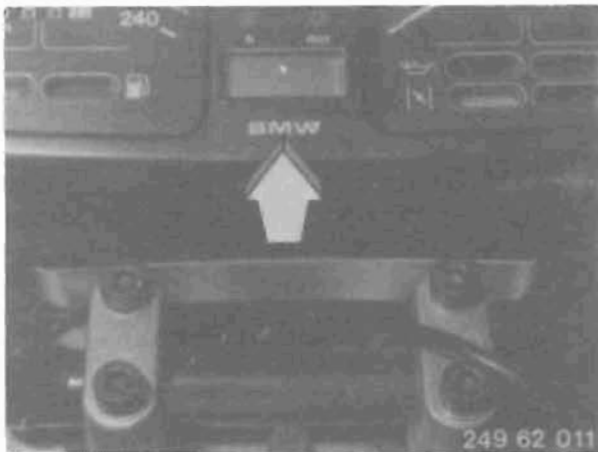

Pull mounting bracket up to remove. Raise instrument cluster slightly. Remove cap and disconnect plug. Take out the instrument cluster.

Assemble following the same procedure but in the reverse order.

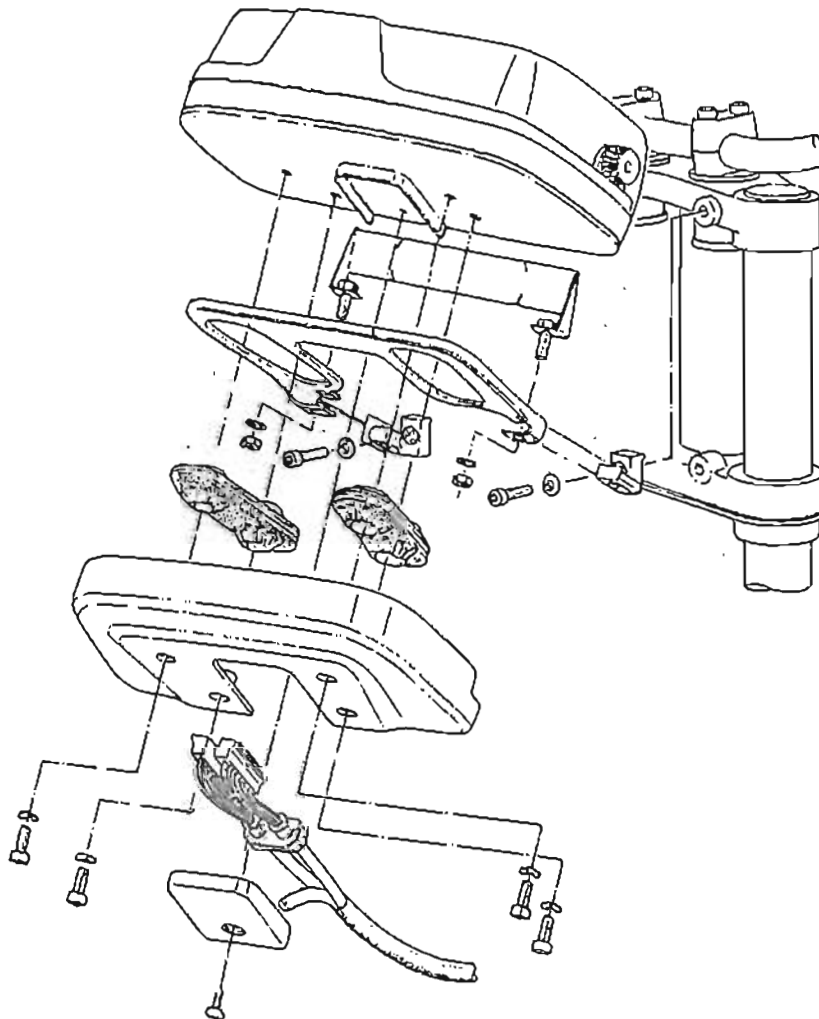

Instrument cluster – stripping down and assembling

Remove retaining screws (arrows) and take off the rear panel.

Notes:

Note gasket.

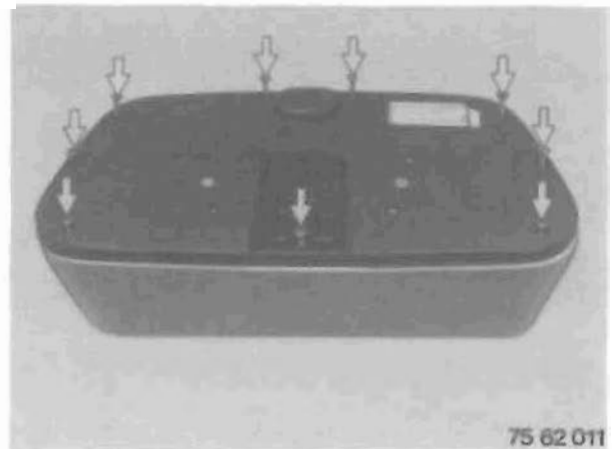

75 62 011

Printed circuit board – removing and installing

Remove retaining screw (arrow) on lower left of circuit board.

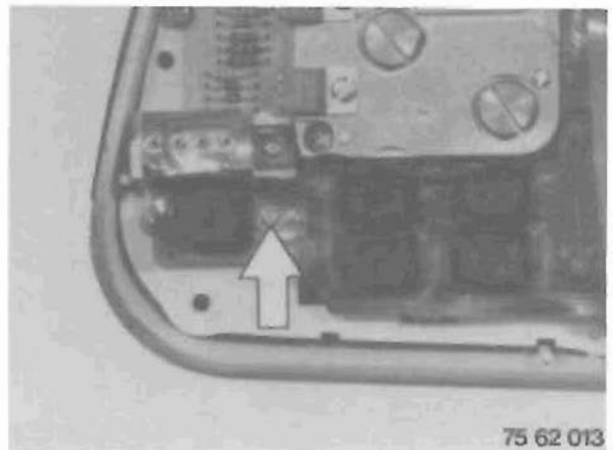

75 62 013

Remove retaining screw (arrow) on lower right of circuit board.

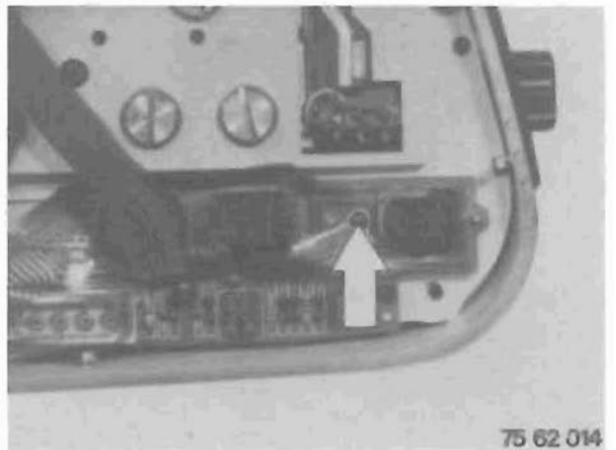

75 62 014

Remove retaining screws (arrows) at centre of circuit board base.

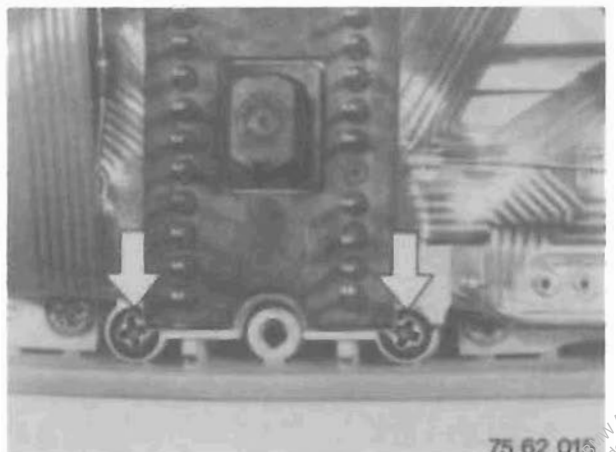

75 62 015

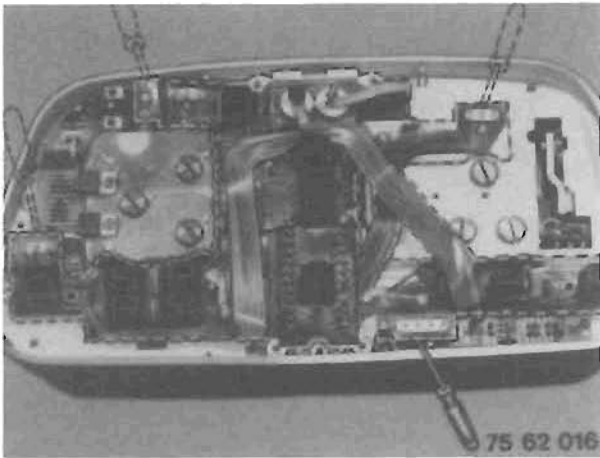

Carefully lever out circuit board (dotted line 1) at plug contacts with a small screwdriver and remove.

When installing:

When assembling, ensure that the plug contacts are correctly located.

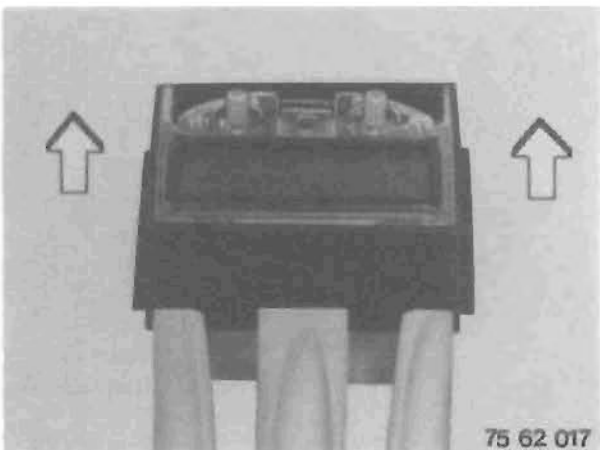

Quartz clock – removing and installing

Pull up quartz clock frame (1) to remove.

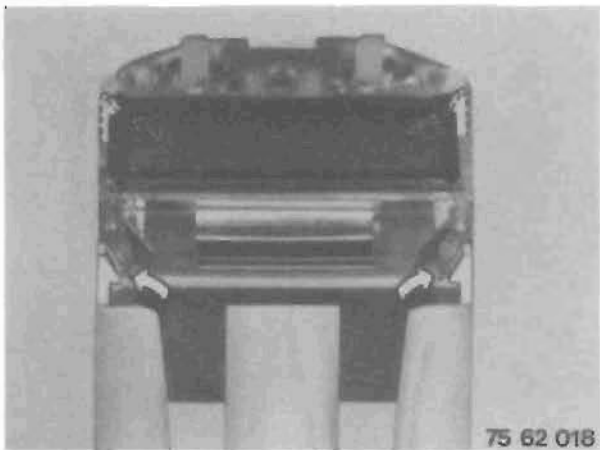

Carefully press out the four quartz clock retaining hooks, then pull the clock up to remove.

Note:

Release first the front two hooks, then the rear two.

When installing:

When assembling, ensure that the plug contacts are correctly located.

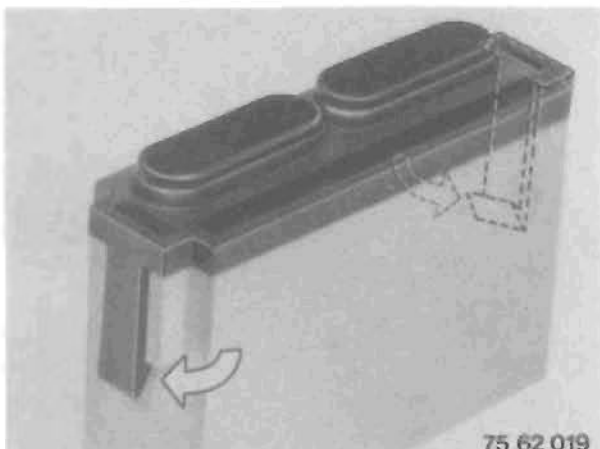

Telltale light frame – removing and installing

Press out hooks and take off telltale light frame.

Fuel gauge board – removing and installing

Remove retaining screws (arrows) and take out fuel gauge board.

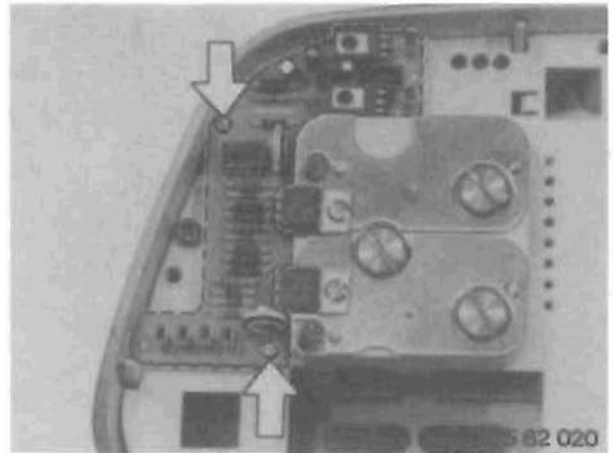

Revolution counter – removing and installing

Remove retaining screw (arrow) for revolution counter and take out revolution counter.

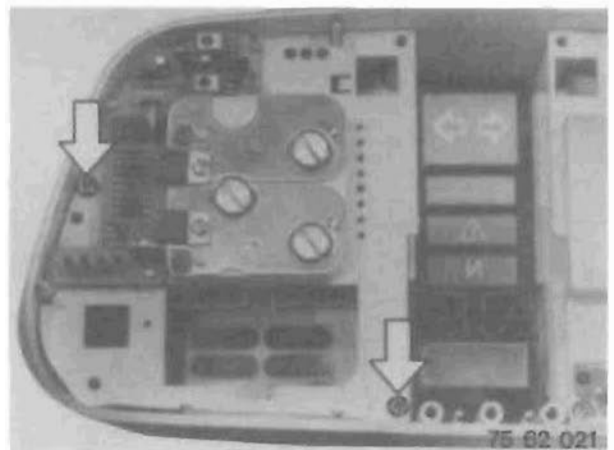

Revolution counter dial – removing and installing

Carefully pull needle off mounting.
Remove retaining screws and take off dial.

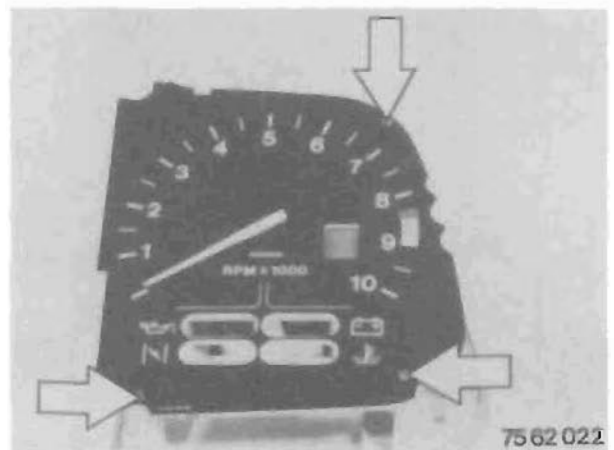

Gear indicator board – removing and installing

Turn over revolution counter.
Remove retaining screws (arrows) and pull out gear indicator board to the side.

Note:
Note spacer.

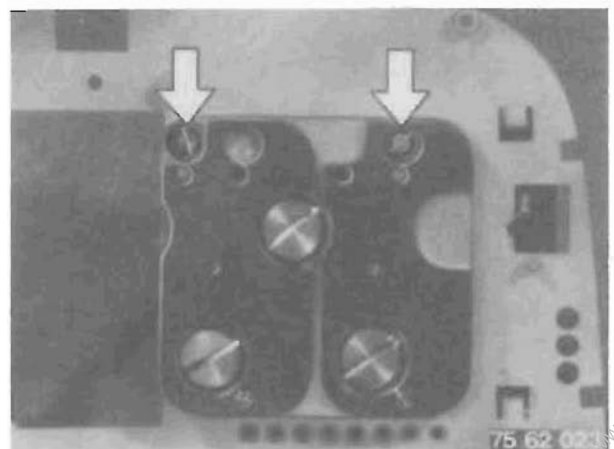

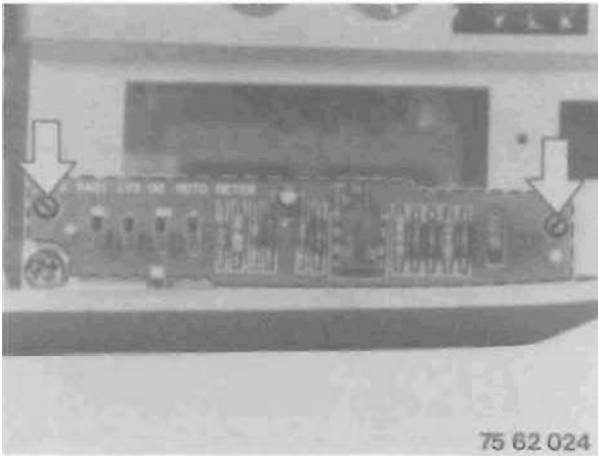

Speedometer board – removing and installing

Remove retaining screws (arrows) and take off speedometer board.

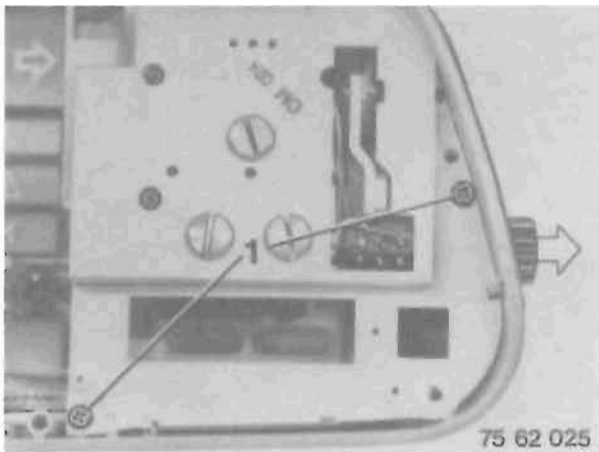

Speedometer – removing and installing

Remove speedometer retaining screws (1). Pull out reset button for distance trip recorder as far as possible in the direction of the arrow and take out the speedometer.



Telltale light – renewing

Grip bulb socket diagonally with BMW relay pliers 61 1 250, turning the pliers to and fro; take care not to damage the conducting paths.

Assemble the instrument cluster in the reverse order. Take care not to bend the conducting paths when inserting.

63

Lights

63 Lights

Technical data	Page	63-03.0
Headlight setting – checking		63-04.0
K 75 headlight – adjusting		63-04.0
K 75 c, K 100 headlight – adjusting		63-04.0
K 75 s headlight – adjusting		63-05.0
K 100 RS, RT, LT headlight – adjusting		63-05.0
K 75 headlight – removing and installing		63-06.0
K 75 c, K 100 headlight – removing		63-07.0
K 75 c, K 100 headlight – installing		63-08.0
K 75 s headlight – removing and installing		63-08.0
K 100 RS, RT, LT headlight – removing and installing		63-08.0
Rear light cluster – removing and installing		63-09.0

Lights

Specifications

Model		K 75	K 75 c	K 75 s	K 100	K 100 RS	K 100 RT	K 100 LT
Headlights	mm	180 Ø		170×110	180 Ø	200×130		
Bulbs		H4 halogen bulb, 60/55 W, asymmetric						
Full/dipped beam								
Parking lights	DIN 72601	12 V / 4 W standard designation T 8/4						
Rear light:								
Driving light	DIN 72601	12 V / 10 W, standard designation R 19/10						
Brake light	DIN 72601	12 V / 21 W, standard designation P 25-1						
Turn indicators	DIN 72601	12 V / 21 W (4×) standard designation P 25-1						
Instrument cluster:								
Turn indicator telltales	DIN 72601	12 V / 4 W (2×) standard designation T 8/4						
Other telltales and instrument lights	DIN 72601	12 V / 3 W (13×) standard designation W 10/3						

Headlight setting – adjusting

After any work affecting the headlight, check its adjustment. If no suitable beam aligning device is available, this work can be carried out as follows.

- Check tyre pressures and correct if necessary.
- Set the suspension for solo riding

The motorcycle should stand on its wheels, with the rider's weight on the dualseat, on a flat, level surface 5 metres from a light-coloured wall.

Measure the distance from the floor to the centre of the headlight. Mark this distance on the wall with a cross, and make another cross 5 cm below the first. Switch on the low (dipped) headlight beam and align the headlight so that the light-dark boundary of the beam runs to the left of the lower cross, rises to the height of the upper cross to the right of the centreline, then falls away again.

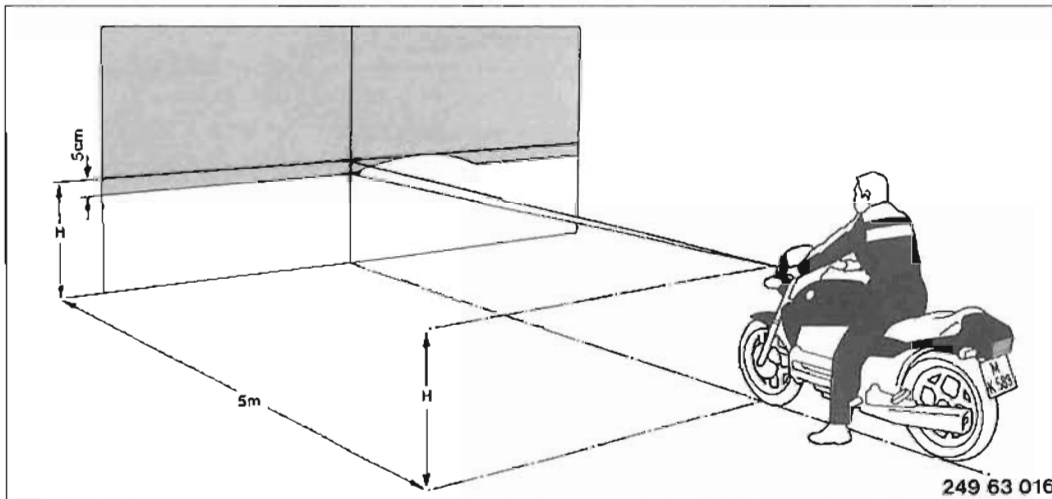

K 75 headlight – adjusting

Slacken off headlight retaining screws (arrows). Adjust headlight according to diagram above.

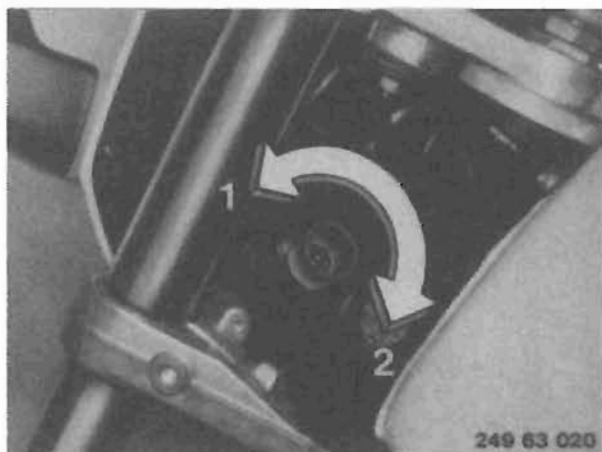

K 75 c, K 100 headlight – adjusting

Adjust the headlight according to the diagram above at the knurled screw by the left-hand telescopic fork fixed tube.

Turned in direction (1) (anticlockwise) = beam throw shorter

Turned in direction (2) (clockwise) = beam throw longer

K 75 s headlight – adjusting

Adjust the headlight according to the diagram on page 63–04.0 at the knurled screw (1) in front of the left-hand telescopic fork fixed tube, beneath the fairing.

Turned anticlockwise = beam throw shorter

Turned clockwise = beam throw longer

The knurled screw for lateral adjustment is located beneath the fairing in front of the right-hand telescopic fork fixed tube.

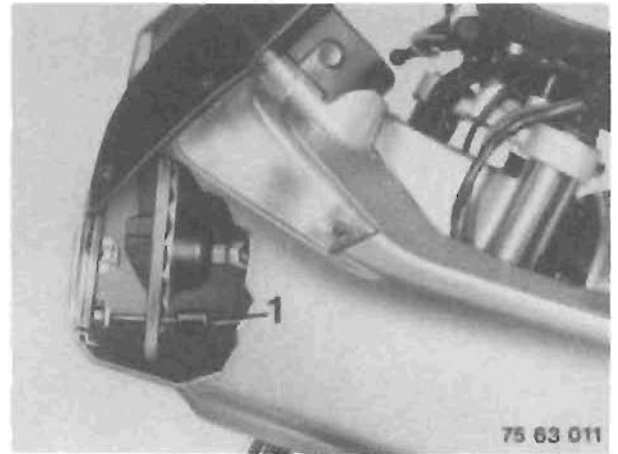

K 100 RS, RT, LT headlight – adjusting

The beam throw adjustment mechanism is located in front of the right-hand telescopic fork fixed tube. The 3-stage lever (1) should be in the top position; screw (2) is for fine adjustment. Adjust according to diagram on page 63-04.0.

Turned anticlockwise = beam throw shorter

Turned clockwise = beam throw longer

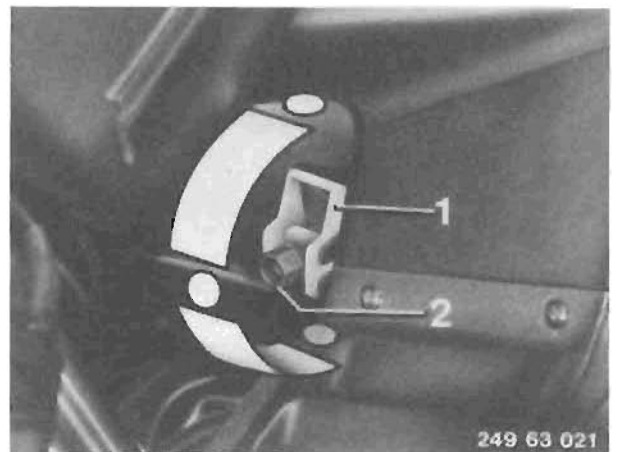

The knurled screw for lateral adjustment is located beneath the fairing in front of the right-hand telescopic fork fixed tube.

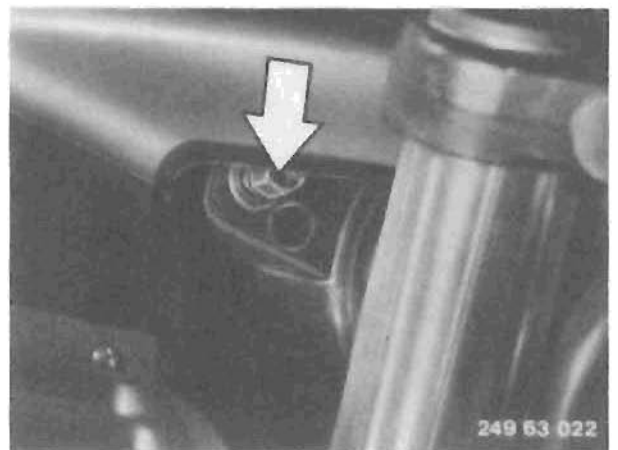

K 75 headlight – removing and installing

Remove retaining screw (arrow) and take headlight out of housing.

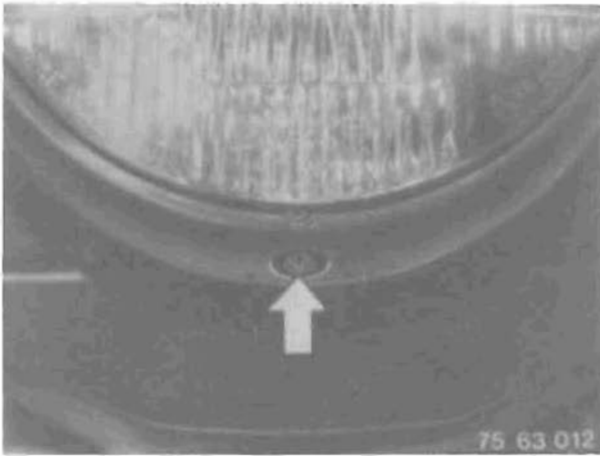

Pull plugs (1, 2, 3) off headlight and take off headlight.

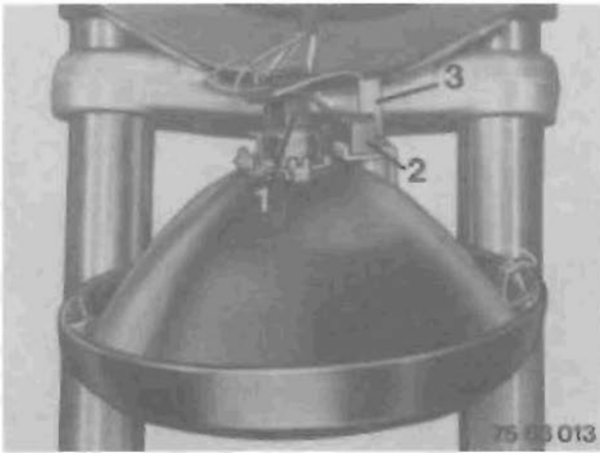

Remove retaining screws on left and right (arrows) for headlight housing and take off housing.



K 75 c, K 100 headlight – removing and installing

Headlight fairing – removing

Remove retaining screws on left (arrows) and right, pull the fairing forward to remove and allow to hang down freely.

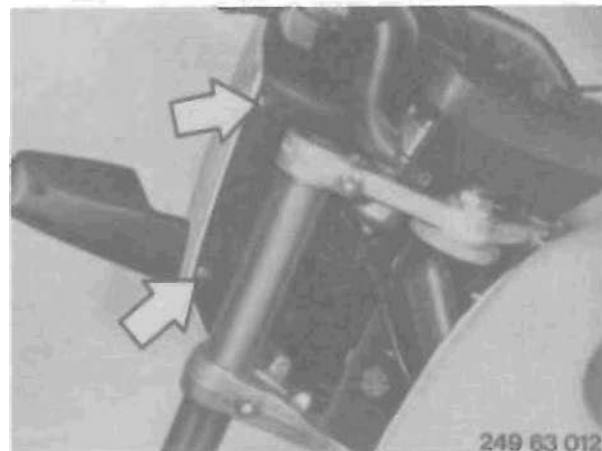

Cockpit fairing – removing

Remove retaining screws (arrows) for cockpit holder on left and right.

Tilt forward cockpit fairing together with turn indicator housing.

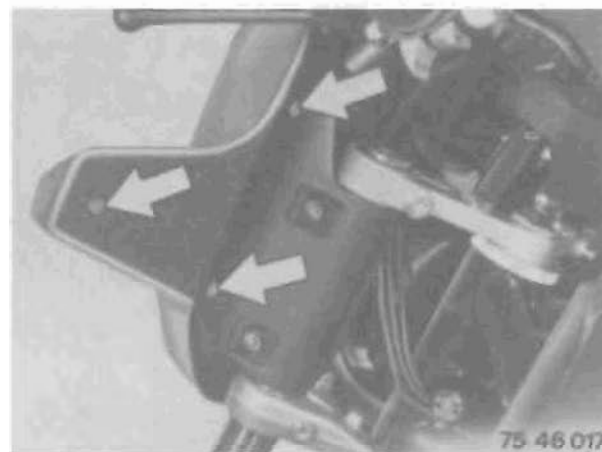

Disconnect turn indicator lead plug (arrow) and take off the cockpit fairing.



Slacken off retaining nuts for headlight, pull hook for beam throw adjustment out of rear panel and pull headlight out of holder.

Disconnect plugs on headlight for H4 bulb and parking light.

Take off headlight.

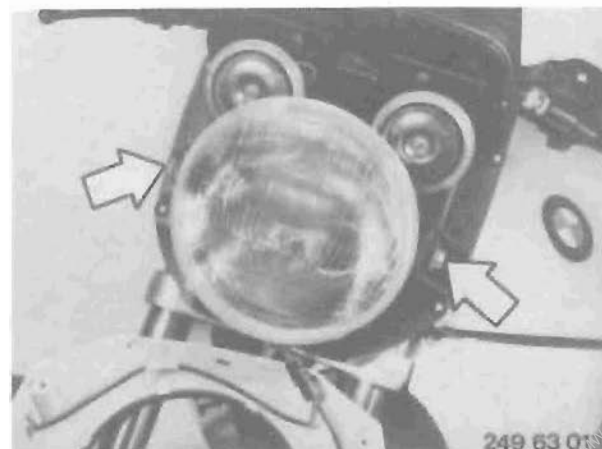

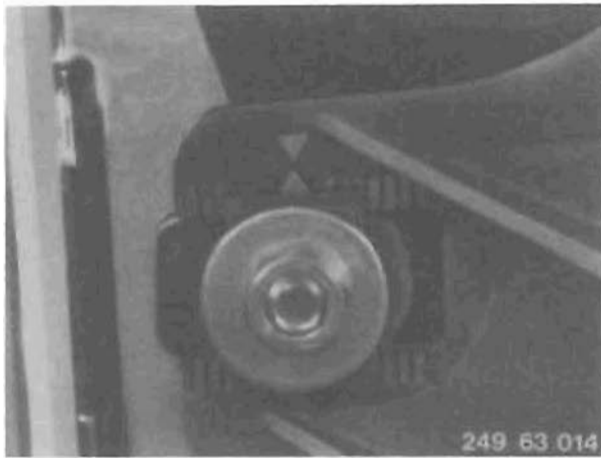

K 75 c, K 100 headlight – installing

Connect up plugs on headlight for H4 bulb and parking light.
Only push the headlight into the holder until the mark on the engaging plate is aligned with the mark on the holder.

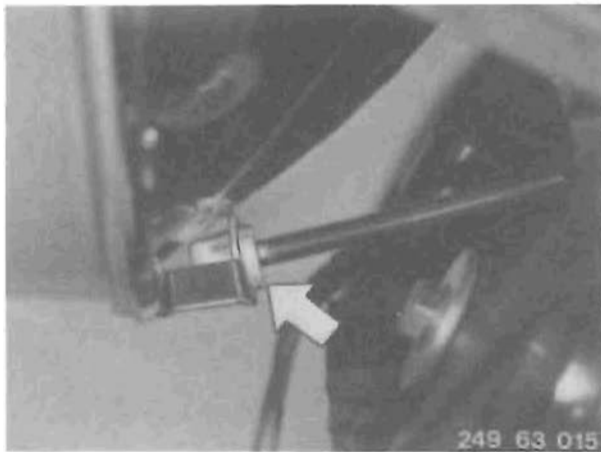

Press headlight adjusting device (arrow) into front headlight ring.
Tighten headlight retaining nut.

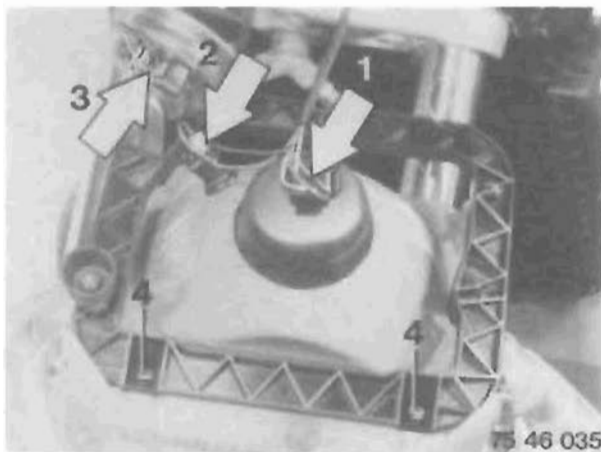

K 75 s headlight – removing and installing

Remove fairing side and centre sections (see Group 46).

Pull off plugs for

- H4 bulb (1)
- Parking light bulb (2) and
- Horn (3).

Remove headlight ring retaining screws (4). Take off headlight ring together with headlight and horn. Lever headlight out of the three pivots.

Assemble following the same procedure but in the reverse order.

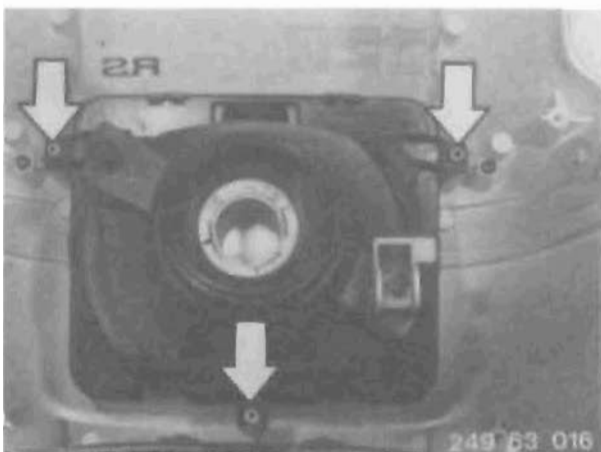

K 100 RS, RT, LT headlight – removing and installing

Remove fairing (see Group 46).

Remove retaining screws (arrows) and take out complete headlight.

Assemble following the same procedure but in the reverse order.

Rear light cluster – removing and installing

Open the dualseat, take off the storage compartment lid and remove 2 knurled screws in the storage compartment (arrows); take out rear light cluster to the rear.

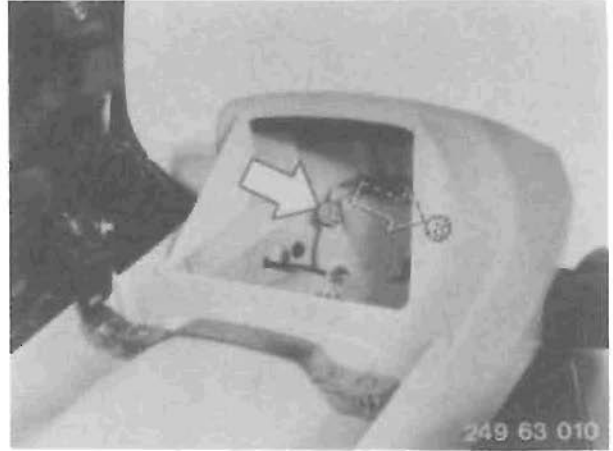

Push in the bulb holder clamp (arrow) and take out the socket.

Assemble following the same procedure but in the reverse order.

